

UNIVERSIDADE FEDERAL DO PARANÁ

GABRIEL RODRIGUES FAVERO

BIOSYNTHESIS OF CANNABINOIDS BY HETEROLOGOUS EXPRESSION IN  
MICROORGANISMS: DOWNSTREAM DEVELOPMENT AND *IN SILICO* SENSITIVITY  
ANALYSIS OF METABOLIC PATHWAYS

CURITIBA

2022

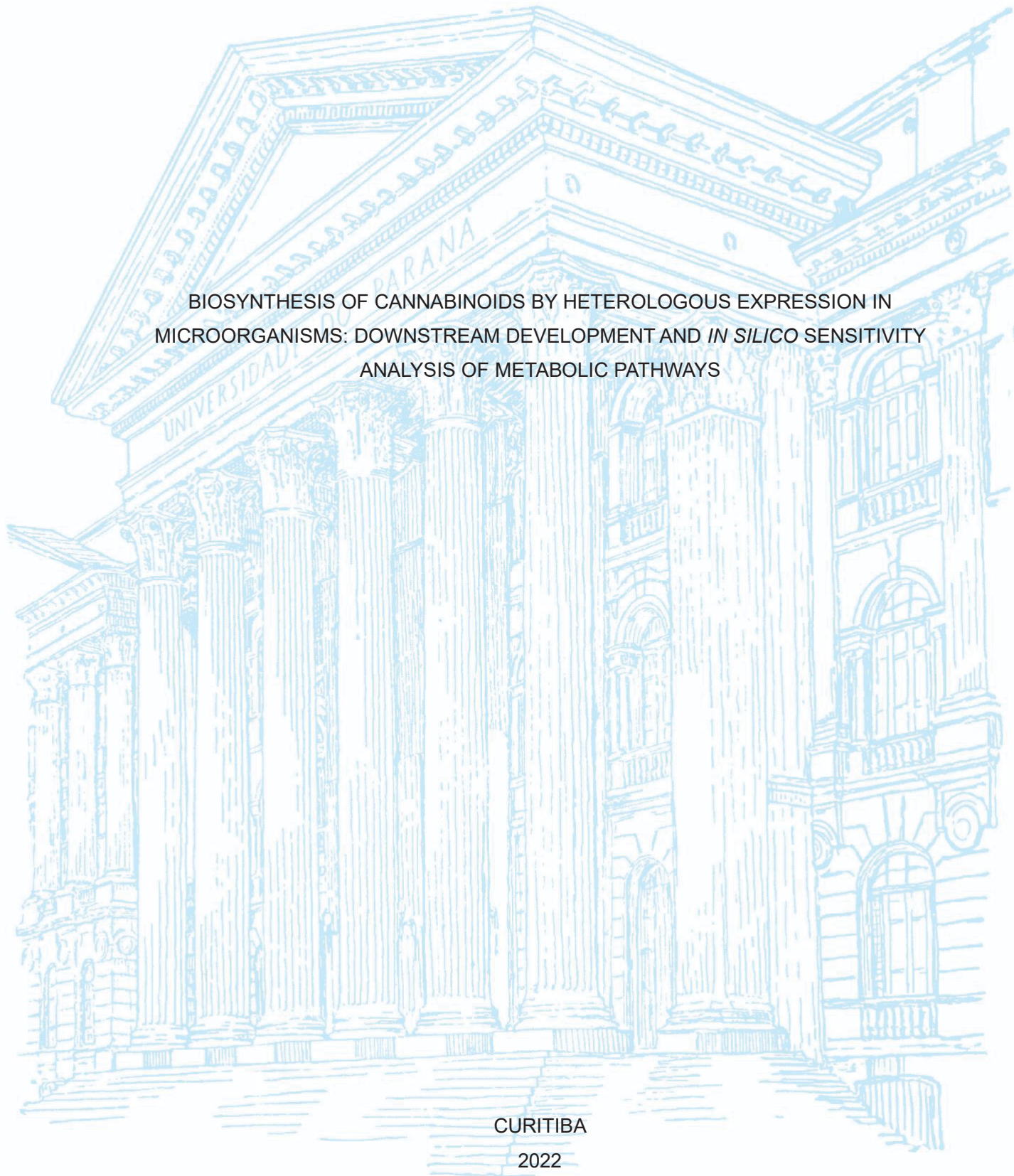

GABRIEL RODRIGUES FAVERO

BIOSYNTHESIS OF CANNABINOIDS BY HETEROLOGOUS EXPRESSION IN  
MICROORGANISMS: DOWNSTREAM DEVELOPMENT AND IN SILICO SENSITIVITY  
ANALYSIS OF METABOLIC PATHWAYS

Dissertação apresentada ao Curso de Pós-Graduação em Engenharia de Bioprocessos e Biotecnologia, Setor de Tecnologia, da Universidade Federal do Paraná, como requisito parcial à obtenção do título de Mestre em Engenharia de Bioprocessos e Biotecnologia.

Orientador: Prof. Dr. Gilberto Vinícius de Melo Pereira.

Coorientador: Prof. Dr. Carlos Ricardo Soccol.

CURITIBA

2022

DADOS INTERNACIONAIS DE CATALOGAÇÃO NA PUBLICAÇÃO (CIP)  
UNIVERSIDADE FEDERAL DO PARANÁ  
SISTEMA DE BIBLIOTECAS – BIBLIOTECA CIÊNCIA E TECNOLOGIA

Favero, Gabriel Rodrigues

Biosynthesis of cannabinoids by heterologous expression in microorganisms: downstream development and in silico sensitivity analysis of metabolic pathways. / Gabriel Rodrigues Favero. – Curitiba, 2022.

1 recurso on-line : PDF.

Dissertação (Mestrado) – Universidade Federal do Paraná, Setor de Tecnologia, Programa de Pós-Graduação em Engenharia de Bioprocessos e Biotecnologia.

Orientador: Prof. Dr. Gilberto Vinícius de Melo.

Coorientador: Prof. Dr. Carlos Ricardo Soccol.

1. Biotecnologia. 2. Indústria. 3. Cannabis sativa. 4. Fermentação. I. Melo, Gilberto Vinícius de. II. Soccol, Carlos Ricardo. III. Universidade Federal do Paraná. Programa de Pós-Graduação em Engenharia de Bioprocessos e Biotecnologia. IV. Título.

Bibliotecário: Nilson Carlos Vieira Junior CRB-9/1797

## TERMO DE APROVAÇÃO

Os membros da Banca Examinadora designada pelo Colegiado do Programa de Pós-Graduação ENGENHARIA DE BIOPROCESSOS E BIOTECNOLOGIA da Universidade Federal do Paraná foram convocados para realizar a arguição da Dissertação de Mestrado de **GABRIEL RODRIGUES FAVERO** intitulada: **BIOSYNTHESIS OF CANNABINOIDS BY HETEROLOGOUS EXPRESSION IN MICROORGANISMS: DOWNSTREAM DEVELOPMENT AND IN SILICO SENSITIVITY ANALYSIS OF METABOLIC PATHWAYS**, sob orientação do Prof. Dr. GILBERTO VINICIUS DE MELO PEREIRA, que após terem inquirido o aluno e realizada a avaliação do trabalho, são de parecer pela sua APROVAÇÃO no rito de defesa.

A outorga do título de mestre está sujeita à homologação pelo colegiado, ao atendimento de todas as indicações e correções solicitadas pela banca e ao pleno atendimento das demandas regimentais do Programa de Pós-Graduação.

CURITIBA, 27 de Abril de 2022.

Assinatura Eletrônica

28/04/2022 12:30:37.0

GILBERTO VINICIUS DE MELO PEREIRA  
Presidente da Banca Examinadora

Assinatura Eletrônica

28/04/2022 14:11:53.0

ANTONIO IRINEUDO MAGALHÃES JÚNIOR  
Avaliador Interno Pós-Doc (UNIVERSIDADE FEDERAL DO PARANÁ)

Assinatura Eletrônica

28/04/2022 10:47:02.0

JULIO CESAR DE CARVALHO  
Avaliador Interno (UNIVERSIDADE FEDERAL DO PARANÁ)

Assinatura Eletrônica

28/04/2022 15:35:10.0

LUIZ ALBERTO JUNIOR LETTI  
Avaliador Externo (UNIVERSIDADE FEDERAL DO PARANÁ)

I dedicate this work to all mankind, with high hopes that science will always illuminate the dark paths that guide us to understanding, freeing us from ignorance and intolerance.

## **AGRADECIMENTOS**

A meus pais, Rose e Vicente, pelos incansáveis conselhos e ensinamentos, mas principalmente pelo amor e apoio incondicional.

Ao professor Dr. Gilberto Vinícius de Melo Pereira, por abraçar a ideia, pela orientação, apoio, paciência, confiança e, principalmente, cafés. Sem você, nada disso seria possível!

Ao professor Dr. Dão Pedro de Carvalho Neto, por sua imensa contribuição nesse trabalho, mas também por sua disposição e aconselhamento durante o mestrado.

Ao professor Dr. Júlio Cesar de Carvalho Neto, por suas sugestões e revisões.

A todos que, de qualquer maneira, me incentivaram, apoiaram, leram, revisaram, traduziram ou sugeriram. Esse trabalho é nosso!

Ao CNPq e à CAPES, pelo auxílio financeiro.

Por fim, a você, leitor. Espero que você possa encontrar informações úteis para complementar sua própria pesquisa e incentivar trabalhos futuros nesse tema.

*The true sign of intelligence is not knowledge but imagination.*

*Albert Einstein*

## RESUMO

O mercado legal de cannabis internacional está enfrentando novos desafios em relação à inovação na produção de drogas à base de canabinoides. A produção tradicional de canabinoides envolve o cultivo de *Cannabis sativa* L. ao ar livre ou estufas com condições de crescimento controladas, seguidas por etapas de isolamento e purificação. Este processo é limitado pelos ciclos de crescimento da planta, onde o teor de canabinoides pode variar profundamente a cada colheita. Como alternativa, a produção de canabinoides por fermentação é uma nova abordagem que vem ganhando a atenção da indústria por não envolver o cultivo de plantas. A partir de leveduras e bactérias recombinantes, pesquisadores estão reproduzindo as vias biossintética para gerar canabinoides, como (-)- $\Delta^9$ -tetrahydrocannabinol ( $\Delta^9$ -THC), canabidiol (CBD) e (-)- $\Delta^9$ -tetrahydrocannabivarin ( $\Delta^9$ -THCV). Essa abordagem evita pesticidas e o uso de recursos naturais, como água, terra e energia, é reduzido. Em comparação ao cultivo de cannabis, a fermentação é um processo muito mais rápido, embora tenha limitações relativas à ampla gama fitoquímica de moléculas naturalmente presentes na cannabis. Até o momento, não há um processo consolidado para a produção de canabinoides por via fermentativa, sendo um conceito emergente e promissor para países onde o cultivo de *Cannabis sativa* L. é ilegal. Esta pesquisa discute as técnicas e microrganismos já estabelecidos e associados à produção microbiana de canabinoides, explorando vantagens e limitações sobre vias metabólicas, toxicidade e recuperação de canabinoides ao longo da produção heteróloga. Potenciais aplicações terapêuticas de canabinoides e metodologia *in silico* para otimização de vias metabólicas também são exploradas. Além disso, esta pesquisa propõe uma análise conceitual para ilustrar a recuperação e purificação de canabinoides através do processo de fermentação, e uma análise de patentes é apresentada a fim de fornecer o estado da arte da transferência de conhecimento da esfera científica à aplicação industrial.

Palavras-chave: Biossíntese de canabinoides; *Cannabis sativa*; Canabidiol; Fermentação; Expressão heteróloga; Engenharia metabólica; Tetrahydrocannabinol; Tetrahydrocannabivarin.



## ABSTRACT

The legal cannabis market worldwide is facing new challenges regarding innovation in the production of cannabinoid-based drugs. The usual cannabinoid production involves growing *Cannabis sativa* L. outdoor or in dedicated indoor growing facilities, followed by isolation and purification steps. This process is limited by the growth cycles of the plant, where the cannabinoid content can deeply vary from each harvest. A game change approach that does not involve growing a single plant has gained the attention of the industry: cannabinoids fermentation. From recombinant yeasts and bacteria, researchers are being able to reproduce the biosynthetic pathway to generate cannabinoids, such as (-)- $\Delta^9$ -tetrahydrocannabinol ( $\Delta^9$ -THC), cannabidiol (CBD), and (-)- $\Delta^9$ -tetrahydrocannabivarin ( $\Delta^9$ -THCV). This approach avoids pesticides, and natural resources such as water, land, and energy are reduced. Compared to growing cannabis, fermentation is a much faster process, although its limitation regarding the phytochemical broad range of molecules naturally present in cannabis. So far, there is not a consolidated process for this brand-new approach, being an emerging and promising concept for countries in which cultivation of *Cannabis sativa* L. is illegal. This survey discusses the techniques and microorganisms already established to accomplish the task and those yet in seeing for the future, exploring upsides and limitations about metabolic pathways, toxicity, and downstream recovery of cannabinoids throughout heterologous production. Therapeutic potential applications of cannabinoids and *in silico* methodology toward optimization of metabolic pathways are also explored. Moreover, a conceptual downstream analysis is proposed to illustrate the recovery and purification of cannabinoids through the fermentation process, and a patent landscape is presented to provide the state-of-the-art of the transfer of knowledge from the scientific sphere to the industrial application.

Keywords: Cannabinoids biosynthesis; *Cannabis sativa*; Cannabidiol; Fermentation; Heterologous expression; Metabolic engineering; Tetrahydrocannabinol; Tetrahydrocannabivarin.

## SUMMARY

<b>1</b>	<b>INTRODUCTION</b> .....	<b>11</b>
1.1	OBJECTIVES.....	12
1.1.1	General objectives.....	12
1.1.2	Specific objectives.....	12
<b>2</b>	<b>LITERATURE REVIEW</b> .....	<b>13</b>
2.1	THERAPEUTIC POTENTIAL OF CANNABINOIDS .....	13
2.2	BIOSYNTHESIS OF PHYTOCANNABINOIDS .....	17
2.3	METABOLIC ENGINEERING TOWARDS PHYTOCANNABINOIDS BIOSYNTHESIS IN MICROORGANISMS .....	20
2.3.1	Design of a suitable host.....	20
2.3.2	Culture medium, production system, and broth composition.....	21
2.3.3	From sugar to cannabinoids .....	22
2.3.4	Metabolic engineering <i>in silico</i> .....	24
2.4	PATENT PROSPECTION .....	25
<b>3</b>	<b>PROCESS DESIGN</b> .....	<b>31</b>
3.1	PROCESS FLOWCHART .....	31
3.2	PROCESS DESCRIPTION .....	32
<b>4</b>	<b>SENSITIVITY ANALYSIS WITH SIMBIOLOGY®</b> .....	<b>34</b>
4.1	MODELING CONDITIONS AND CHARACTERIZATION.....	34
4.2	SIMULATION WITH ORIGINAL PARAMETERS .....	36
4.3	SENSITIVITY ANALYSIS.....	37
4.3.1	Increase in GPP rate of formation.....	37
4.3.2	Increase in OA rate of formation .....	38
4.3.3	Increase in CBGA rate of formation .....	39
4.4	OVERALL RESULTS .....	40
<b>5</b>	<b>CONCLUSIONS, FURTHER ANALYSES AND IMPROVEMENTS</b> .....	<b>41</b>

<b>6</b>	<b>REFERENCES.....</b>	<b>42</b>
----------	------------------------	-----------

## 1 INTRODUCTION

The global cannabis and cannabinoids market has undergone a great increase in recent years with legalization for medical and recreational purposes in different U.S. states and countries. In 1996, California (CA) was the first U.S. state to legalize medical cannabis use (1). Five years later, Canada was the first country in the modern era to legalize medical cannabis nationwide, establishing public policies that became a reference in this subject (2). The recreational use of cannabis was not accepted in the USA until 2012 when Washington (WA) (3) and Colorado (CO) (4) passed a ballot initiative for this purpose. In a global scenario, Uruguay was the first country to legalize the recreational use of cannabis nationwide in 2013 (5), followed by Canada in 2018 (6).

Although the global cannabidiol (CBD) market has been valued at US\$ 2.8 billion in 2020 and has a compound annual growth rate (CAGR) of 21.2% projected to 2028 (7), its commercialization is still restrictive. Furthermore, the usual cannabinoid production is attached with the agricultural process of growing *Cannabis sativa* L., either in outdoor fields or in dedicated indoor growing facilities. The flowers are harvested and the active compounds are isolated through chemical (e.g., extraction with ethanol, ethyl acetate, butane, and CO<sub>2</sub>) or physical (such as heated press) processes to take cannabinoids out of the vegetal biomass (8).

The agriculture-based process requires a significant amount of energy, especially light, and chemical fertilizers. As with any agricultural commodity, it is limited by the slow growth cycles of the plant, where the cannabinoid content can vary from one cycle to another, and are susceptible to pests, weather, and environmental specificities (9). As matter of fact, environmental conditions play an important role in mineral nutrient availability, affecting secondary metabolites' final concentration in plants. The work of Shiponi and Bernstein, 2021, evaluated the hypothesis that phosphorous (P) uptake, distribution, and availability in the plant affects cannabinoids' biosynthesis. By analyzing two genotypes of medical "drug-type" cannabis grown under five P concentrations (5, 15, 30, 60, and 90 mg/L), it was noted that the values lower than 15 mg/L were insufficient to support optimal plant function, with reduced physiological responses, whereas values between 30 and 90 mg/L were within the optimal range for plant development, increasing total cannabinoids content per plant. With that, the regime of mineral nutrients must be adjusted to account for production goals and the genetic specificities of the strain. Moreover, the indoor production of cannabis is responsible for greenhouse gas (GHG) emissions that range between 2 and 5 tons of CO<sub>2</sub>-equivalent per kg of dried flower – attributed to electricity and natural gas consumption from indoor environmental controls, high-intensity grow lights, and supply of CO<sub>2</sub> to accelerate plant growth (11).

With the advance of metabolic engineering and synthetic biology, the tailor-made design of cell factories became a reality, providing a remarkable opportunity for the biosynthesis of cannabinoids and analogs, especially for those found in small quantities in cannabis. As matter of fact, the expression of tetrahydrocannabinol synthase (THCAS) was already achieved using *P.*

*pastoris* as host (12). With cannabigerolic acid (CBGA) being added into the media,  $\Delta^9$ -tetrahydrocannabinolic acid ( $\Delta^9$ -THCA) was synthesized. Luo et al., 2019, were able to produce several cannabinoids and analogs from the genetic recombination of *Saccharomyces cerevisiae* (13), generating a yeast that can synthesize cannabinoids from galactose. With specific genetic modifications, cannabinoids that were previously generated in small quantities can now be scaled up. Furthermore, there is no need for pesticides and the natural resources required (land, water, and energy) are reduced as well CO<sub>2</sub> footprint.

However, a drawback of fermentation is its limitation to achieve the phytochemical broad range of molecules naturally present in *Cannabis sativa* L., turning full-spectrum extracts (i.e., those with phytocannabinoids and secondary metabolites) unfeasible to be obtained other than by the plant. The term *entourage effect* (14) is often used to refer to potential synergies between chemical compounds present in cannabis, such as cannabinoids-cannabinoids interactions (15–17) and the presence of other secondary metabolites such as terpenes/terpenoids (18). The list of terpenes/terpenoids found in cannabis is vast due to differences between strains, chemotypes, and environmental conditions, but in general, the most common terpenes/terpenoids found are  $\beta$ -myrcene, limonene, linalool,  $\beta$ -caryophyllene,  $\alpha$ -pinene,  $\beta$ -ocimene, terpinolene and geraniol (18). They are mainly responsible for the odor and taste present in cannabis flowers and are used world widely in perfume fragrances and cleaning products. Besides these organoleptic characteristics, terpenes/terpenoids have been studied for their therapeutic potential, with works analyzing analgesic (19–21), anti-inflammatory (22–26), gastroprotective (27–29), anxiolytic/anti-depressant (30–35), apoptotic/antimetastatic (36,37) antinociceptive (38–40), neuroprotective (41–44), sedative/motor relaxant (45–47), and antifungal (48,49) properties. This broad range of metabolites in different concentrations provides unique therapeutic applications for full spectrum extracts.

## 1.1 OBJECTIVES

### 1.1.1 General objectives

This survey discusses the techniques and microorganisms already established during cannabinoids' heterologous expression in microorganisms, and those yet in seeing for the future, exploring upsides and limitations about metabolic pathways, toxicity, and downstream recovery of cannabinoids throughout heterologous production.

### 1.1.2 Specific objectives

- Compile and systemize the therapeutic potential applications of cannabinoids;
- Present a patent landscape to provide the state-of-the-art of the transfer of knowledge from the scientific sphere to the industrial application;

- Provide a conceptual downstream analysis to illustrate the recovery and purification of cannabinoids through the fermentation process;
- Analyze which variables mostly impair the process scale up through *in silico* methodology, assessing metabolic bottlenecks during cannabinoids heterologous expression in microorganisms;

## 2 LITERATURE REVIEW

### 2.1 THERAPEUTIC POTENTIAL OF CANNABINOIDS

Cannabinoids are active lipophilic compounds that interact with specific protein receptors in the human body, constituting a system of physiological regulations – the endocannabinoid system. Two receptors for this system are well known: CB<sub>1</sub>, located in the central nervous system (CNS) and peripheral nervous system (PNS), with high density in the basal ganglia, cerebellum, hippocampus and, cortex; and CB<sub>2</sub>, restricted to immune tissues and immune cells. Some cannabinoids are produced endogenously in various vertebrates and are known as endocannabinoids, such as anandamide (AEA) and 2-arachidonylglycerol (2-AG) (50). Other cannabinoids are produced only by plants of the genus *Cannabis* (mainly by *sativa* and *indica* species), including (-)- $\Delta^9$ -tetrahydrocannabinol ( $\Delta^9$ -THC) and cannabidiol (CBD), and are known as phytocannabinoids (18). Over 500 chemical compounds were identified in *C. sativa* L., including 102 phytocannabinoids, being  $\Delta^9$ -THC, CBD, cannabigerol (CBG), and cannabichromene (CBC) their main representatives (51). In the plant, they are usually found in their carboxylated state, including tetrahydrocannabinolic acid ( $\Delta^9$ -THCA) and cannabidiolic acid (CBDA). Although cannabinol (CBN) is one of the major cannabinoids found in cannabis, it is not directly produced by the plant, being a product of  $\Delta^9$ -THC oxidation (52). Phytocannabinoids are separated into families based on their structures such as cannabigerol (CBG)-family, cannabichromene (CBC)-family, cannabidiol (CBD)-family, tetrahydrocannabinol (THC)-family, cannabinol (CBN)-family (53) (FIGURE 1). They are all composed of a phenolic (resorcinol) moiety and a monoterpene moiety, later described in this survey.

The effects of cannabinoids were studied only from the 20th century, where several analyses resulted in the development of dronabinol (Marinol®; Unimed Pharmaceuticals, Inc, Marietta, GA, USA). This drug is based on  $\Delta^9$ -THC, which in 1964 – and after decades of attempts to isolate and determine its chemical structure – was identified as the main psychoactive component of cannabis. Together with Cesamet® (Valeant Pharmaceuticals North America, Aliso Viejo, CA, USA), they were the first cannabinoid-based drugs to be prescribed in the United States, presenting antiemetic and appetite-stimulating action for patients with cancer and AIDS (50). Several studies are being carried out for possible pharmacological applications involving cannabinoids, especially with CBD due to the absence of psychoactive effects. Conditions such as

Alzheimer's disease, anxiety, cancer, chronic pain, depression, epilepsy, inflammatory diseases, multiple sclerosis, and Parkinson's disease are being investigated with promising results (54).

FIGURE 1 – Structures of endocannabinoids and major phytocannabinoids present in *C. sativa* L. THC: tetrahydrocannabinol, CBN: cannabinol, CBD: cannabidiol, CBC: cannabichromene, CBG: cannabigerol.

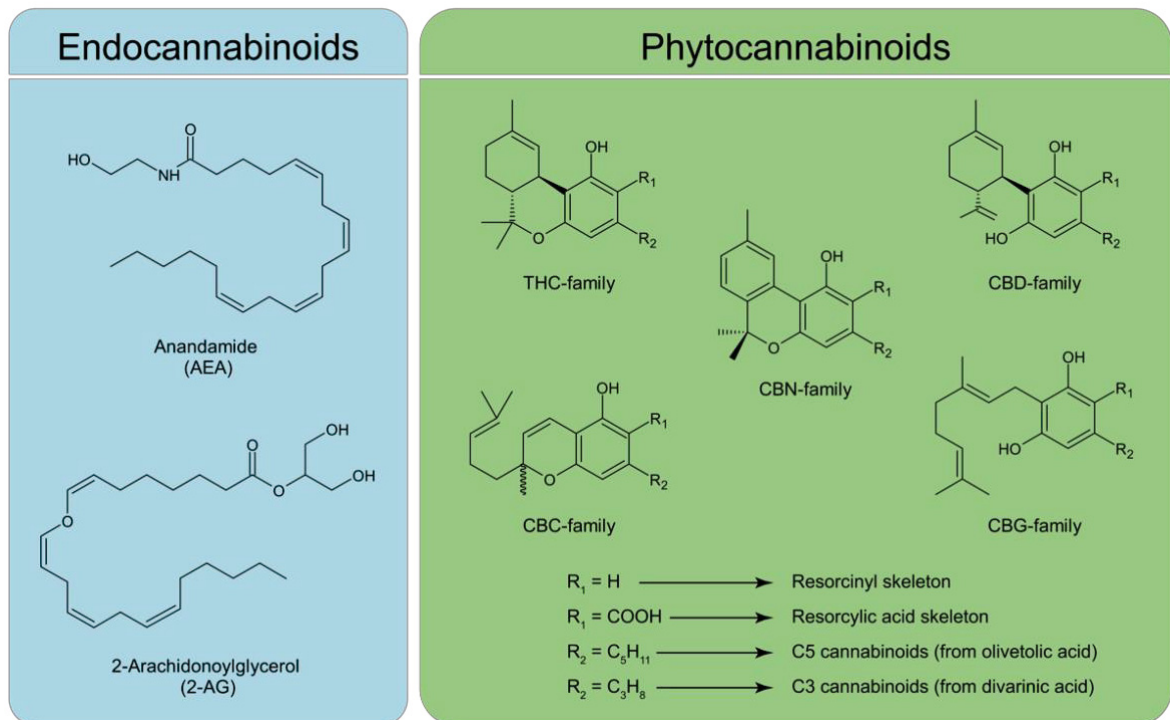

REFERENCE: Adapted from (53).

A few phytocannabinoids present psychoactive effects, which are responsible for the high sensation that cannabis users experience. For instance,  $\Delta^9$ -THC has psychoactive properties, while CBD does not show any (50). CB<sub>1</sub> receptor agonist is a primary condition for psychoactive molecule action, which is mainly conducted by its retrograde inhibition on both excitatory and inhibitory terminals of presynaptic neurons. Once activated, CB<sub>1</sub> suppresses the release of neurotransmitters by inhibiting voltage-gated Ca<sup>+2</sup> channels to reduce ion influx and by inhibiting adenylyl cyclase to stop the signaling pathway (55,56). This cascade of physiological responses in the CNS are responsible for boosting appetite and modulating mood (57). Consequently, substances that can antagonize CB<sub>1</sub> receptors are being used to treat metabolic syndrome and obesity (58).  $\Delta^9$ -THC is an agonist of the CB<sub>1</sub> and CB<sub>2</sub> receptors ( $K_{i,CB1} = 35.64 \pm 12.4$  nM,  $K_{i,CB2} = 8.45 \pm 6.0$  nM), while CBD shows much lower receptor affinity ( $K_{i,CB1} = 1458.5 \pm 158.5$  nM,  $K_{i,CB2} = 372.37 \pm 57.5$  nM) (55), justifying  $\Delta^9$ -THC psychoactive effects. It was also found that CBD is an inverse agonist at the human CB<sub>2</sub> receptor, which can contribute for its anti-inflammatory effects (54). The psychoactive group of phytocannabinoids is illustrated in FIGURE 2, and is mainly composed by the THC-family,



including  $\Delta^9$ -THC,  $\Delta^8$ -THC, (-)- $\Delta^9$ -tetrahydrocannabivarin ( $\Delta^9$ -THCV) (59) in high doses (i.e., > 10 mg/kg in mice (60)), and also CBN (55). Since different molecules bind with different affinities to receptors, the psychoactive effect can be mild or pronounced, ultimately being an affinity/concentration related mechanism. Thus, there is still much to be understood about other phytocannabinoids and their possible interactions and synergies.

FIGURE 2 - Main phytocannabinoids found in *Cannabis sativa* L. classified into psychoactive and non-psychoactive.  $\Delta^9$ -THC:  $\Delta^9$ -tetrahydrocannabinol,  $\Delta^8$ -THC:  $\Delta^8$ -tetrahydrocannabinol, CBN: cannabivarin,  $\Delta^9$ -THCV:  $\Delta^9$ -tetrahydrocannabivarin,  $\Delta^9$ -THCA:  $\Delta^9$ -tetrahydrocannabinolic acid, CBC: cannabichromene, CBG: cannabigerol, CBD: cannabidiol.

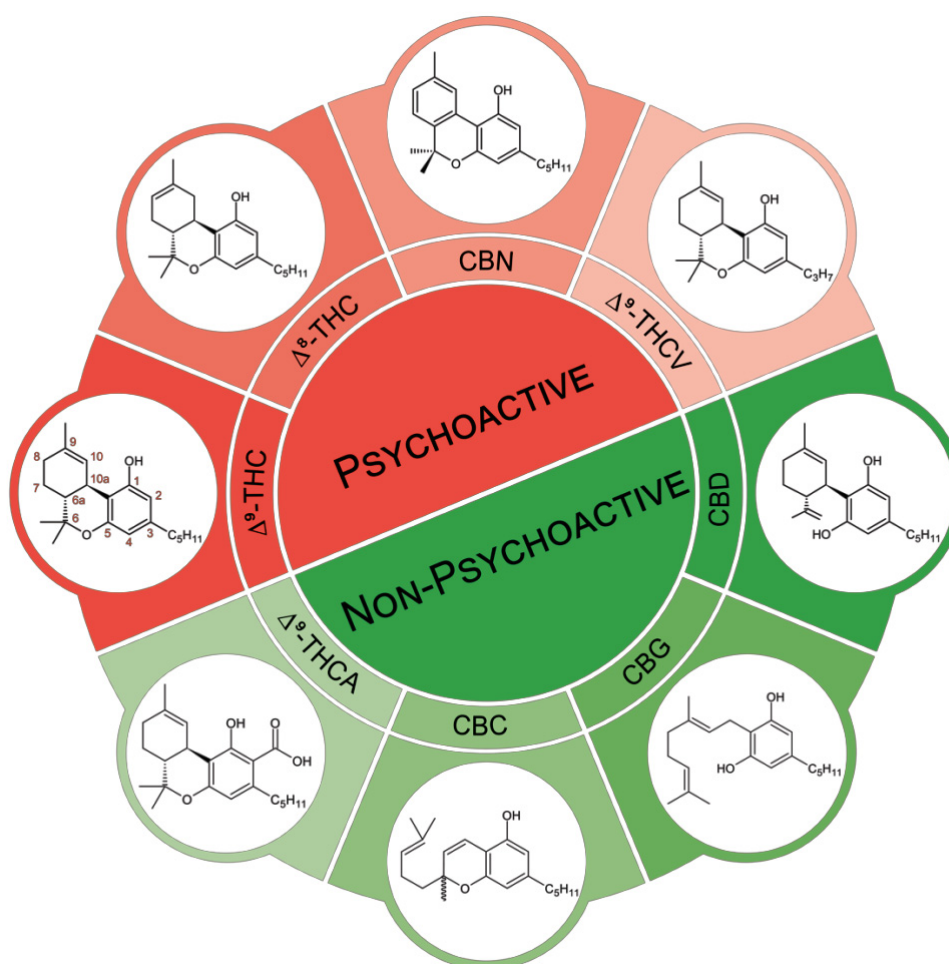

REFERENCE: Adapted from (50,58,61,62).

In TABLE 1 are presented updated references about the therapeutic potential of cannabinoids and its applications. The data was collected through research on PubMed and Scopus, and is composed by *in vitro/in vivo* studies, reviews, and book chapters of the referenced subject. Nevertheless, this data collection is intended to be used *only* as a research tool, and not as self-treatment guide for any condition without a physician supervision.



TABLE 1 - Therapeutic potential application for the previously showed phytocannabinoids. CBD: cannabidiol,  $\Delta^9$ -THC:  $\Delta^9$ -tetrahydrocannabinol, CBG: cannabigerol,  $\Delta^9$ -THCV:  $\Delta^9$ -tetrahydrocannabivarin, CBC: cannabichromene, CBN: cannabiol. Positions marked with a “-” had inconclusive or no data at the moment this survey was carried out.

Therapeutic potential	CBD	$\Delta^9$ -THC	CBG	$\Delta^9$ -THCV	CBC	CBN
Analgesic	(65–68)	(69,70)	(71)	(72)	(73,74)	(68,75)
Anorectic	-	-	-	(76,77)	-	-
Anti-cancer	(78,79)	(78,80)	(73,81,82)	-	(73,83)	(84,85)
Anti-depressant	(86–89)	(89)	(71,83)	-	(89)	-
Anti-inflammatory	(90,91)	(92,93)	(73,94)	(72)	(95–97)	(98)
Anti-ischemic	(99)	(100)	-	-	-	-
Antibacterial	(101–103)	(101,103)	(103,104)	(103)	(73,95,103,104)	(103)
Antiemetic	(105)	(105,106)	(107)	(108)	-	-
Antiepileptic	(109,110)	(111)	-	(112)	-	-
Antifungal	-	-	(104)	-	(73,95,104)	-
Antipsoriatic	(113,114)	-	(115)	-	-	(115)
Antipsychotic	(88,116,117)	-	-	(118)	-	-
Antispasmodic	(67,119,120)	(119,120)	-	-	-	-
Anxiolytic	(87,88,121)	(122,123)	-	(124)	-	-
Appetite stimulant	-	(125,126)	(73)	-	-	(127)
Bone healing/formation	(128–131)	(131)	(130,131)	(131)	-	(131)
Immune modulator	(132,133)	(134,135)	-	-	-	(136,137)
Neuroprotective	(121,138–140)	(139,141)	(140,142)	(141,143)	(144)	(145)

Finally, posology and drug delivery are factors to be analyzed for the patient security and well-being. The cannabinoids/terpenoids mixture are usually inhaled by smoking/vaporization or taken orally via tinctures or oils. Also, oromucosal, topical-transdermal and rectal routes are minor used but possible (63). Since pharmacokinetics vary as a function of its route of administration, the effects can be modulated through the chosen posology. Inhaled  $\Delta^9$ -THC maximum plasma concentration was detected within minutes, and psychotropic effects were pronounced after 15-30 minutes, ceasing after 2-3 hours. Oral ingestion psychotropic effects had a delay of 30-90 minutes, achieving maximum effect after 2-3 hours and lasting for about 4-12 hours (64). The better understanding of these factors is crucial for the correct dosage, avoiding adverse effects.

## 2.2 BIOSYNTHESIS OF PHYTOCANNABINOIDS

Phytocannabinoids are synthesized and stored within glandular trichomes that are present on cannabis flowers with some extension to other structures, such as leaves and stems, but almost absent in seeds and roots (62). To produce these compounds in a heterologous host, the genes, metabolic pathways, bottlenecks, and specificities involved during phytocannabinoids biosynthesis in *Cannabis sativa* L. must be comprehended and availed, in order to be further optimized according to the host's characteristics and limitations.

The biosynthesis of cannabinoids begins with metabolic pathways to produce geranyl pyrophosphate (GPP) and olivetolic acid (OA) as shown in FIGURE 3 (61). Geranyl pyrophosphate (GPP) is mainly biosynthesized via the 2C-methyl-D-erythritol-4-phosphate (MEP) pathway, also known as non-mevalonate or 1-deoxy-D-xylulose-5-phosphate (DOXP) pathway, and in a small extension through mevalonate (MVA) pathway (61,146). The final products, isopentenyl pyrophosphate (IPP) and dimethylallyl pyrophosphate (DMAPP), are catalyzed to GPP by the action of geranyl pyrophosphate synthase (GPPS), providing the monoterpene moiety of phytocannabinoids (147). In parallel, the polyketide pathway towards OA starts with hexanoic acid produced either by an early termination of fatty acid biosynthesis or by the breakdown of C18 unsaturated fatty acids via the lipoxygenase pathway (148). The hexanoic acid is converted to hexanoyl-CoA by the action of an acyl-activating enzyme type 1 (AAE1) found in *Cannabis sativa* (CsAAE). Then, a type III tetraketide synthase (CsTKS), also known as olivetol synthase (OLS), promotes the aldol condensation of hexanoyl-CoA with three molecules of malonyl-CoA, producing olivetol, followed by the C2-C7 aldol cyclization to OA carried by a polyketide cyclase (CsOAC) (149). With an olivetolic acid pool, the phenolic (resorcinol) moiety is available to be further converted into cannabinoids. More details regarding MEP/DOXP pathway, MVA pathway, fatty acid biosynthesis, and lipoxygenase pathway are summarized in several reviews (150–153) with higher plants metabolism focus.

With the availability of the precursors, an aromatic prenyltransferase named geranylpyrophosphate:olivetolate geranyltransferase (GOT) is responsible to convert GPP and OA into cannabigerolic acid (CBGA) (13), the central precursor for phytocannabinoids biosynthesis. This enzyme was detected in 1998 and is assumed to be an integral membrane protein, although some activity was found in soluble fractions (154,155).

With an appropriated CBGA pool, enzymes such as THCA synthase, CBDA synthase, and CBCA synthase promote an oxidative cyclization of the monoterpene moiety of the substrate, generating  $\Delta^9$ -THCA, CBDA, and CBCA, respectively. In the plant, the phytocannabinoids are stored as carboxylic acid; they can be decarboxylated to their corresponding neutral form through drying, heating, or combustion (156).

FIGURE 3 - Phytocannabinoids biosynthesis in *Cannabis sativa* L. The monoterpene moiety is provided majoritarian through the MEP/DOXP pathway, and in small extension through the MVA pathway, in which geranyl pyrophosphate (GPP) is synthesized. Parallel to that, fatty acids metabolism uses hexanoic acid as a substrate to fulfill the phenolic (resorcinol) moiety of cannabinoids, generating olivetolic acid (OA). Through the action of cannabigerolic acid synthase (CBGAS), GPP and OA are converted into cannabigerolic acid (CBGA), the central precursor for many other cannabinoids, such as  $\Delta^9$ -tetrahydrocannabinolic acid ( $\Delta^9$ -THCA), cannabidiolic acid (CBDA) and cannabichromenic acid (CBCA).

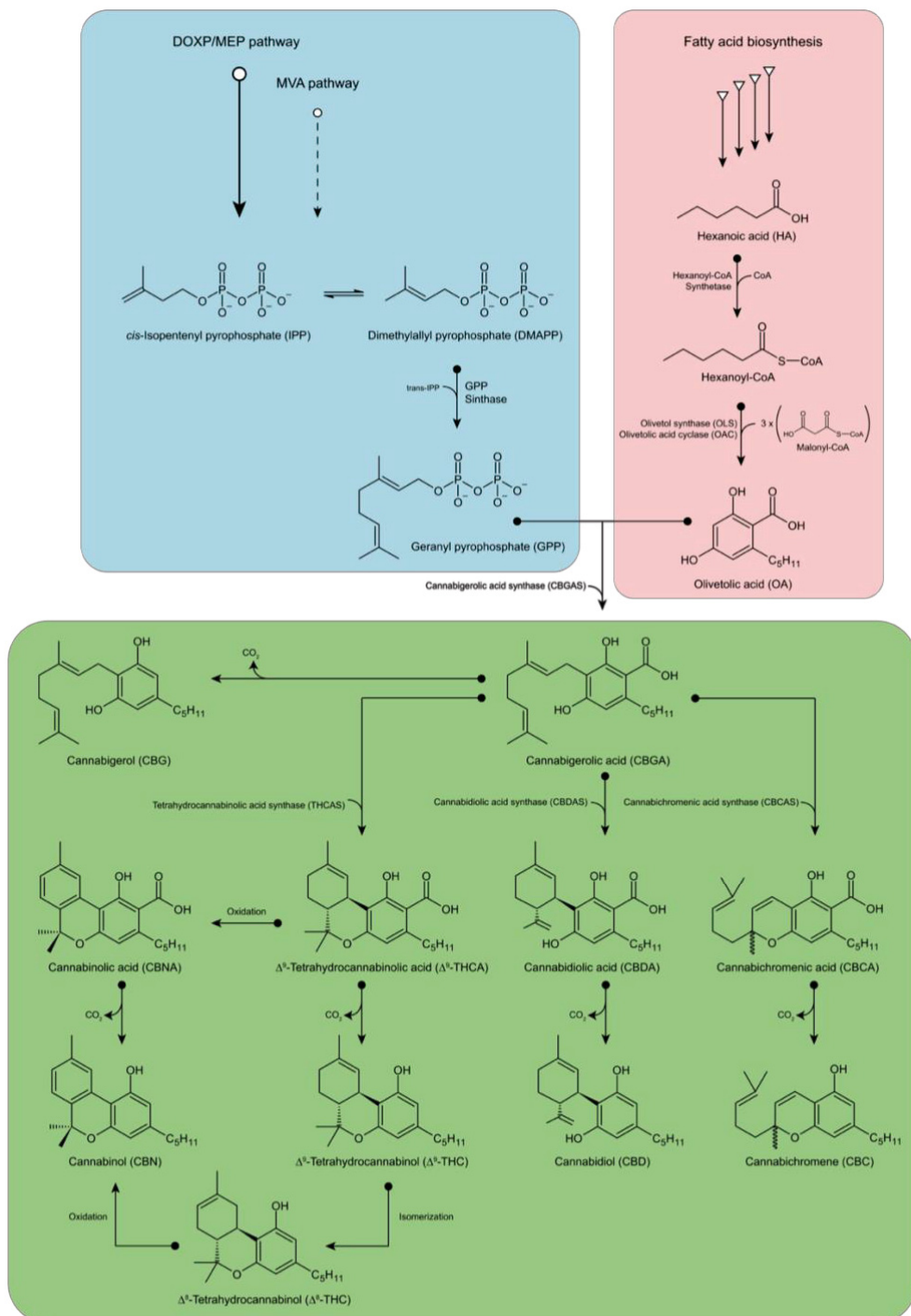

REFERENCES: Adapted from (13,61,62,156).

Phytocannabinoids such as CBGA,  $\Delta^9$ -THCA, CBDA, and CBCA are known as C5 phytocannabinoids since they have an n-pentyl side chain in the phenolic moiety. However, there are also C3 phytocannabinoids, or propyl cannabinoids, derived not from olivetolic acid (OA) but from divarinic acid (DA) as illustrated in FIGURE 4. The prenylation of DA with GPP results in cannabigerovarinic acid (CBGVA), the central precursor for C3 phytocannabinoids biosynthesis. The cannabinoid synthase enzymes are not alkyl length selective and can convert CBGVA into the propyl homologous of THCA, CBDA, and CBCA, known as tetrahydrocannabivarinic acid ( $\Delta^9$ -THCVA), cannabidivarinic acid (CBDVA), and cannabichromevarinic acid (CBCVA), respectively (157). Since these compounds are not commonly produced by cannabis strains due to dissimilar enzyme specificities at the level of CBGA or CBGA-analogs formation (158), the analysis and studies of its therapeutic value are impaired. Nevertheless, the agricultural-based method has the genetic restrictions imposed by the plant, with selective breeding as the main resource to achieve better yields of a specific compound, despite its limited randomness expressed in the next offspring. With that, chemotype inheritance and genetic engineering are the objects of study to manipulate secondary metabolites' final concentration and can be conferred in recent works (157,159).

FIGURE 4 - Propyl phytocannabinoids (C3) biosynthesis in *Cannabis sativa* L. Monoterpene moiety is provided majoritarian through the MEP/DOXP pathway, and in small extension through the MVA pathway, in which geranyl pyrophosphate (GPP) is synthesized. The fatty acids metabolism uses butanoic acid as a substrate to fulfill the phenolic (resorcinol) moiety of cannabinoids, generating divarinic acid (DA). Through the action of cannabigerolic acid synthase (CBGAS), GPP and DA are converted into cannabigerovarinic acid (CBGVA), the central precursor for many other C3 cannabinoids, such as  $\Delta^9$ -tetrahydrocannabivarinic acid ( $\Delta^9$ -THCVA), cannabidivarinic acid (CBDVA) and cannabichromevarinic acid (CBCVA).

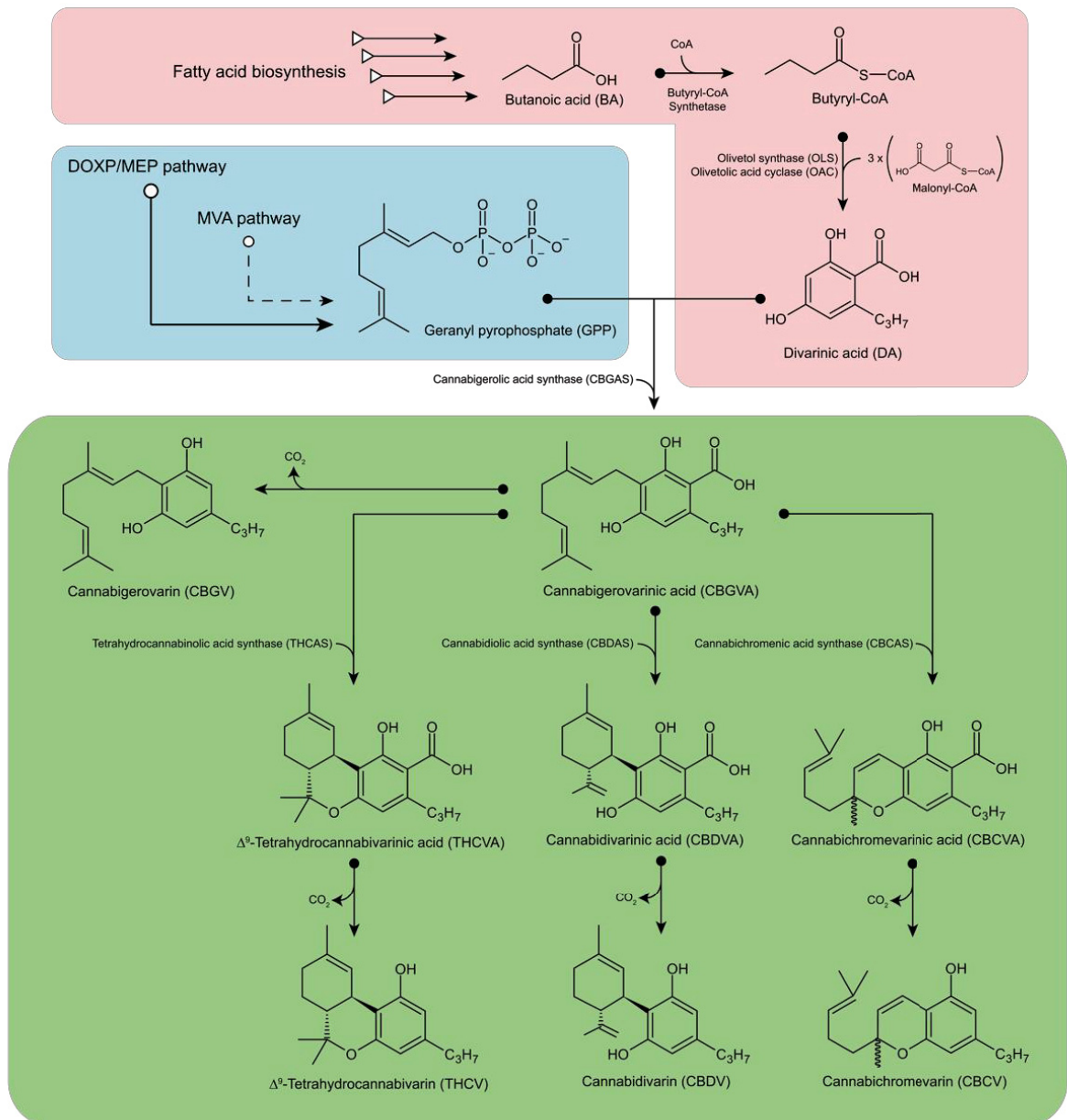

REFERENCES: Adapted from (13,61,62,156).

## 2.3 METABOLIC ENGINEERING TOWARDS PHYTOCANNABINOIDS BIOSYNTHESIS IN MICROORGANISMS

### 2.3.1 Design of a suitable host

A better approach to target the production of non-common cannabinoids can be achieved through the aid of metabolic engineering and synthetic biology. Usually, a safe and well-described cell is chosen as a “cell factory”, a chassis for the production of the desired chemical compound. The chosen cell can express the pathways needed to achieve the product, but, typically, the flux

toward the product is naturally low. Using classic strain improvement or directed genetic modifications (i.e., metabolic engineering), it is possible to increase the flux toward the product. If the cell does not naturally produce the compound of interest, the insertion of a synthetic pathway is necessary. Normally, the product will be generated in small amounts, but the pathway can be optimized to ensure a high flux toward the target, using concepts from both metabolic engineering and synthetic biology. Finally, a complete synthetic cell can be constructed in a manner that its pathways are tailored for the desired product, achieving great yields and low concentration of by-products (160).

Since fermentation of cannabinoids is a relatively new approach, there is no consensus on the best microorganism yet. The first step is to determine which microorganisms can be tailored for heterologous biosynthesis of these compounds. A review published by Carvalho et al., 2017, covers some of the main host characteristics, such as genetic tools available for the microorganism, plant protein expression capacity, possibility of posttranslational modifications, and specific biosynthetic pathways. The microorganisms analyzed in this survey were *Escherichia coli*, *Saccharomyces cerevisiae*, *Komagataella phaffii* (*Pichia pastoris*), and *Kluyveromyces marxianus*, with qualitative indicators regarding hosts characteristics aforementioned. It was noticed that *E. coli* has significant genetic tools reported, and an arsenal of strains, promoters, and vectors, but its limited posttranslational modifications make it unlikely to be a suitable host. All the other microorganisms are yeasts, with *S. cerevisiae* and *K. phaffii* (*P. pastoris*) being the most widely reported in the literature. The yeast *K. marxianus* has been reported to present an efficient hexanoic acid pathway (162), which could solve the low-availability pool of this metabolite during heterologous biosynthesis of cannabinoids.

### 2.3.2 Culture medium, production system, and broth composition

The production of phytocannabinoids by heterologous expression in yeasts has been accomplished through fed-batch liquid cultures (12,13). This production system is indicated for fermentations in which substances are periodically added to the medium to fulfill the chemical demand of the target microorganism. The interval between applications avoids excess toxic substances in the medium, preventing possible detours during biosynthesis or even cell death. As shown by Coral et al., 2008, the medium composition plays an important role to determine the optimal point between biomass and product concentration.

Luo et al., 2019, worked with recombinant *S. cerevisiae* in liquid culture medium. Strains were pre-grown in yeast peptone dextrose extract (YPD) medium overnight and then back-diluted to  $OD_{600} = 0.2$  into yeast peptone galactose extract (YPG), a non-selective culture medium for *Candida*, *Pichia*, *Saccharomyces* and *Zygosaccharomyces* containing 20 g/L of peptone, 10 g/L of yeast extract and 20 g/L of galactose. The medium was supplemented with 1 mM olivetolic acid or corresponding fatty acid (such as hexanoic, pentanoic, and butanoic acid). Strains were incubated



for 24 h, 48 h, or 96 h in 24-deep-well plates (800 r.p.m.) at 30 °C while supplementing with 2% (w/v) galactose every 24 h.

Zirpel et al., 2015, worked with recombinant *E. coli*, *P. pastoris*, and *S. cerevisiae*. Recombinant *E. coli* cells were grown in 1 L flasks, containing 100 mL LB-medium (50 µg kanamycin mL<sup>-1</sup>, 33 µg chloramphenicol mL<sup>-1</sup>, 100 µg spectinomycin mL<sup>-1</sup>) at 37 °C and 200 rpm to an OD<sub>600</sub> of 0.6. THCAS expression was started by the addition of 1 mM IPTG and cells grown for 16 h at 20 °C. Recombinant *S. cerevisiae* cells were grown in minimal medium without leucine at 30 °C and 200 rpm for 24 h. Cells were used to inoculate 100 mL of 2 × YPAD medium at an OD<sub>600</sub> of 0.5 and incubated with 0.5 % (w/v) galactose at 20 °C and 200 rpm for 144 h. Recombinant *P. pastoris* cells were grown in BMGY at 30 °C and 200 rpm for 24 h. Afterward, cells were harvested by centrifugation at 5000 × g for 5 min and resuspended in modified BMMY (mBMMY) (164) to an OD<sub>600</sub> of 20. *Pichia* cells were cultivated at 15 °C and 200 rpm until no increase in THCAS activity could be observed and supplemented with 0.5 % (v/v) methanol every 24 h for protein expression.

### 2.3.3 From sugar to cannabinoids

The main intermediates and genes during phytocannabinoids biosynthesis in *S. cerevisiae* were reported by Luo et al., 2019, and are illustrated in FIGURE 5. The chosen substrate for the microorganism was galactose. The GPP was produced with the introduction of the *EfmvaE* and *EfmvaS* genes of *Enterococcus faecalis* (an acetyl-CoA acetyltransferase/HMG-CoA reductase and an hydroxymethylglutaryl-CoA synthase (165)), and by overexpressing the genes of the mevalonate pathway (*ERG12*, *ERG8*, *ERG19*, and *IDI1*) (166) and a mutated *ERG20*<sup>F96W/N127W</sup> gene (*erg20\**) that preferentially produces GPP over FPP (167). Hexanoyl-CoA was produced heterologously using genes from *Ralstonia eutropha* (*RebktB*, a β-keto thiolase from *Ralstonia eutropha* H16 that catalyzes condensation reactions between acetyl-CoA with acyl-CoA molecules (168)), *Cupriavidus necator* (*CnpaaH1*, an NADH-dependent 3-hydroxyacyl-CoA dehydrogenase (169)), *Clostridium acetobutylicum* (*Cacrt*, a crotonase that catalyzes the dehydration of 3-hydroxybutyryl-CoA to crotonyl-CoA in the n-butanol biosynthetic pathway (170)) and *Treponema denticola* (*Tdter*, a trans-enoyl-CoA reductase (171)), or feeding hexanoic acid as a substrate for AAE (encoded by *CsAAE1* from *Cannabis*). Expression of the genes encoding *CsTKS* and *CsOAC* produced olivetolic acid, which was prenylated by *CsPT4-T*, a geranylpyrophosphate:olivetolate geranyltransferase activity. The resulting CBGA was transformed into Δ<sup>9</sup>-THCA and CBDA using THCAS and CBDAS. After exposure to heat, Δ<sup>9</sup>-THCA and CBDA were decarboxylated to Δ<sup>9</sup>-THC and CBD, respectively. As both Δ<sup>9</sup>-THC and CBD come from CBGA, the insertion of gene copies that encode THCAS or CBDAS will determine which final product is going to be synthesized. The final concentration obtained of Δ<sup>9</sup>-THCA and CBDA was 8.0 mg/L and 4.3 µg/L, respectively. In addition to cannabinoids derived from olivetolic acid, Luo et al., 2019 also produced propyl cannabinoids (from divarinic acid). The hexanoic acid was replaced by butanoic acid, providing an

appropriate butanoyl-CoA pool for the synthesis of C3 cannabinoids. Thus,  $\Delta^9$ -THCVA and CBDVA were produced with concentrations of 4.8 mg/L and 6.0  $\mu$ g/L, respectively (13).

FIGURE 5 - Illustration of main intermediates and genes during phytocannabinoids biosynthesis in *S. cerevisiae* according to the work of Luo et al., 2019. Geranyl pyrophosphate (GPP) was produced with the introduction of the *EfmvaE* and *EfmvaS* genes of *Enterococcus faecalis*, and by overexpressing the genes of the mevalonate pathway (*ERG12*, *ERG8*, *ERG19*, and *IDI1*) and a mutated *ERG20F96W/N127W* gene (*erg20\**). Hexanoyl-CoA was heterologously produced using genes from *Ralstonia eutropha* (*RebktB*), *Cupriavidus necator* (*CnpaaH1*), *Clostridium acetobutylicum* (*Cacrt*), and *Treponema denticola* (*Tdter*), or feeding hexanoic acid as a substrate for AAE (encoded by *CsAAE1* from *Cannabis sativa*). Expression of the genes encoding *CsTKS* and *CsOAC* produced olivetolic acid (OA), which was prenylated by *CsPT4-T*. The resulting CBGA was transformed into  $\Delta^9$ -THCA and CBDA using *THCAS* and *CBDAS*. After exposure to heat,  $\Delta^9$ -THCA and CBDA were decarboxylated to  $\Delta^9$ -THC and CBD, respectively.

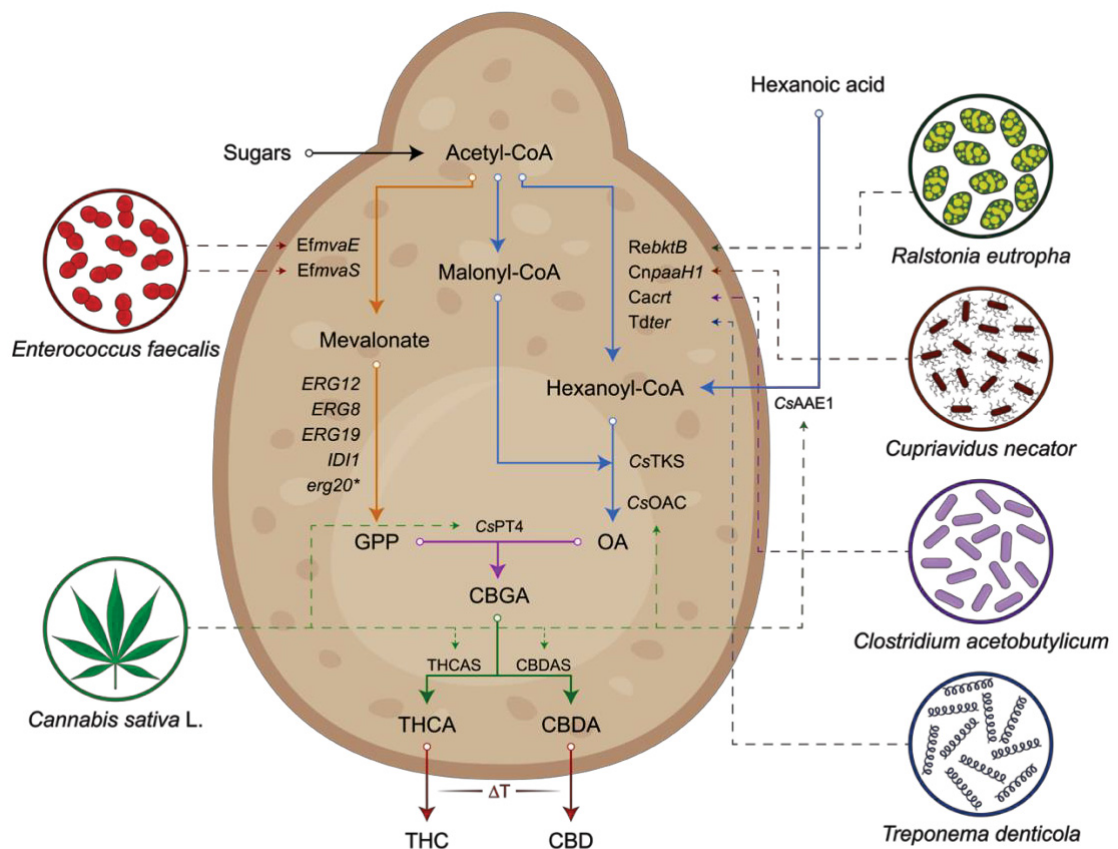

REFERENCE: Adapted from (13).

A list of the enzymes involved during heterologous biosynthesis of phytocannabinoids by *S. cerevisiae* with their respective accession numbers on GenBank is available in TABLE 2.



TABLE 2 - List of enzymes and corresponding GenBank accession numbers involved in heterologous expression of phytocannabinoids in *S. cerevisiae*. <sup>a</sup>Patent number, <sup>b</sup>Application number.

Enzyme	Abbreviation	Accession no.	EC no.	References
Acyl activating enzyme 1	AAE	AFD33345.1	6.2.1.1	(172)
Olivetol synthase (tetraketide synthase 3)	OLS (TKS)	AB164375	2.3.1.206	(173)
Olivetolic cyclase	OAC	AFN42527.1	4.4.1.26	(149)
Geranylpyrophosphate:olivetolate geranyltransferase	GOT (CsPT4-T)	US10975379B2 <sup>a</sup>	2.5.1.102	(13)
Tetrahydrocannabinolic acid synthase	THCAS	AB057805	1.21.3.7	(174)
Cannabidiolic acid synthase	CBDAS	AB292682	1.21.3.8	(175)
Cannabichromenic acid synthase	CBCAS	WO2015196275A1 <sup>b</sup>	1.3.3-	(176,177)

Zirpel et al., 2015 tested the production of  $\Delta^9$ -THCA by heterologous hosts such as *E. coli*, *S. cerevisiae*, and *K. phaffii* (12), in which *S. cerevisiae* and *K. phaffii* showed THCA synthase activity after addition of 1 mM CBGA, leading to a  $\Delta^9$ -THCA production of 0.36 g/L in *K. phaffii*. No functional expression of THCA synthase could be found in *E. coli*, which was concluded by the authors that functional expression of THCAS might require eukaryotic chaperones able to facilitate covalent binding of FAD to the THCAS or glycosylation of the protein.

Renew Biopharma chose the green alga *Chlamydomonas reinhardtii* as a host, stating that it is capable of compartmentalizing the biosynthesis of cannabinoids in its chloroplasts, which protects the rest of the cellular structures (9). This approach resulted in a more expensive downstream since microalgae are known to have a complex cellular wall. For instance, *Chlamydomonas reinhardtii* has a multilayered extracellular matrix, which requires physical and chemical agents in order to rupture it and access the cannabinoids (178).

### 2.3.4 Metabolic engineering *in silico*

Despite the remarkable work accomplished by Luo et al., 2019, the titers of  $\Delta^9$ -THCA (8.0 mg/L) and CBDA (4.4  $\mu$ g/L) obtained were low, making the process economically unfeasible to be scaled up into industrial levels. Improvement and redesign of metabolic pathways towards the product is the main strategy to enhance higher concentrations of cannabinoids. In fact, metabolic bottlenecks for the biosynthesis of  $\Delta^9$ -THCA have been recently analyzed *in silico* and reported (155) for an engineered *S. cerevisiae* strain. The kinetics of reactions toward cannabinoids were modeled using MATLAB<sup>®</sup> with the SimBiology extension (179), in which  $\Delta^9$ -THCA was produced from glucose instead of galactose – a much-appreciated upgrade since galactose is up to 100-fold more expensive than glucose. Nevertheless, a high glucose concentration at the beginning leads

to respiratory inhibition known as the Crabtree effect (180), in which ethanol is produced and the growth rates are slowed.

The first challenge lies in acetyl-CoA, the committed precursor for mevalonate and olivetolic acid pathways, responsible for the GPP and OA pool, respectively. Thomas et al., 2020, suggested the replacement of acetaldehyde dehydrogenase (ADH) as well as acetyl-CoA synthetase with aldehyde dehydrogenase acylating (ADA) from *Dickeya zeeae*, an optimization that grants higher specific activity, demands less energy, and prevents acetate formation. Moreover, the ethanol generated by aerobic cultivation on glucose can be converted back into acetaldehyde with the addition of ADH2 under specific promoter control. In parallel, non-essential pathways can be muted to enhance the carbon flux towards cannabinoids. The peroxisomal citrate synthase and cytosolic malate synthase consume cytosolic acetyl-CoA, being the genes CIT2 and MLS1 excellent targets to be muted to improve acetyl-CoA pool.

The hexanoic acid production is another metabolic bottleneck referring to the limited pool of acetyl-CoA and down related to OA. The low specificity of OAC turns only 5% of all the hexanoic acid into OA and the remaining 95% into olivetol. The feeding of hexanoic acid is advantageous but limited to up to 1 mM due to cell toxicity and slower growth rates. OA feeding is also not recommended due to its high cost, low absorbance by the yeast, and chemical instability. Moreover, the CBGA production is a limiting step toward the optimization of the process as shown by Thomas et al., 2020, in a sensitivity analysis. The membrane-bound enzyme CBGAS from *Cannabis sativa* L. was replaced by the soluble prenyltransferase NphB present in *Streptomyces* spp., especially due to a CBGA-specific variant recently reported (181).

In conclusion, the low availability of acetyl-CoA and hexanoic acid with the low specificity of OAC are the main limiting factors for higher yields. Nevertheless, the  $\Delta^9$ -THCA titer predicted *in silico* after 40 h of fermentation was 299.8 mg/L, a 37-fold increase compared to Luo et al., 2019. Although this value is small close to  $\Delta^9$ -THCA and CBDA present in plants (5-20% in dry weight of extract), it is a great opportunity for the biosynthesis of non-common cannabinoids such as  $\Delta^9$ -THCVA and CBDVA (< 1% in dry weight).

## 2.4 PATENT PROSPECTION

A survey on the free access Patent Inspiration database was conducted using the term (*cannabi\**) as a keyword for search on Title or Abstract, while the terms *microorganism* AND *yeast* AND *production* have been searched on Abstract and Description. The initial results revealed a total of 58 documents filled over the past 20 years proposing the protection of new technologies associated with the biotechnological production of cannabinoids or their derivatives. However, after a thorough analysis, only 16 patents actually protected processes and methods related to the prospected theme (TABLE 3).

TABLE 3 - Data obtained from the patent survey on Patent Inspiration database on cannabinoid biosynthesis via microbial source.

Patent Number	Title	Resume	Country	Applicants	Granted	Citations	Year (Publication)
US9546362B2	Genes and proteins for alkanoyl-coa synthesis	Proposition of genetic engineering of plant, yeast, or bacterial cells with a cassette comprising 13 where homologous, isolated, and/or purified sequences of <i>Cannabis sativa</i> for the production of cannabinoids using carboxylic acids as substrate	Canada	University of Saskatchewan and an and Natural Resources Council	Yes	18	2014
EP3067058A1	Biological composition based on engineered <i>Lactobacillus paracasei</i> subsp. <i>paracasei</i> f19 for the biosynthesis of cannabinoids	Discloses the use of the strain <i>Lactobacillus paracasei</i> subsp. <i>paracasei</i> f19 as a suitable host for <i>Cannabis sativa</i> gene incorporation	Italy	Farmagens Health Care SRL	No	8	2016
US10801049B2	Production of cannabinoids from a carbon sugar precursor	Claims the application of the insertion of the <i>pgi</i> , <i>zwf</i> , and <i>glTA</i> genes and the mutation of the <i>fadD</i> gene to the synthesis of the hexanoyl-CoA precursor from simple sugar sources	USA	Syntiva Therapeutics Inc.	Yes	0	2019
US10392635B2	Production of Tetrahydrocannabinolic Acid in Yeast	Insertion of a mutant aromatic prenyltransferase in yeast models, resulting in a higher yield of geranyl pyrophosphate, an important precursor of the cannabinoids	USA	Librede Inc.	Yes	1	2019

Patent Number	Title	Resume	Country	Applicants	Granted	Citations	Year (Publication)
US10837031B2	Recombinant production systems for prenylated polyketides of the cannabinoid family	Proposes the recombinant production of cannabinoids in yeasts and filamentous fungi through the production of cannabinoid precursors when grown in the presence of exogenous prenil and isoprenol Proposes the commercial-scale production and processing of biosynthetic cannabinoids produced by growing genetically modified microalgae in a photo-bioreactor and the posterior recovery of the cannabinoid via extraction and distillation	USA	Baymedica Inc.	Yes	3	2019
US2020370073A1	Biosynthetic cannabinoid production methods	Discloses the modification of microalgae for the expression of <i>Cannabis sativa</i> encoding genes	USA	Insectery Llc.	No	0	2020
US2020340026A1	Neurotransmitters and Methods of Making the Same	Expression or over-expression of the enzyme that catalyzes the synthesis of aromatic polyketides (e.g., olivetolic acid) which may result in increased production of cannabinoid compounds	USA	Purissima Inc.	No	0	2020
US2020325508A1	Genes and proteins for aromatic polyketide synthesis	Insertion of an overexpressed, bifunctional enzyme ispDF responsible for the synthesis of isoprene, terpenoids, and cannabinoids	Canada	University of Saskatchewan an and Natural Resources Council	No	0	2020
US2020291434A1	Metabolic engineering of <i>E. coli</i> for the biosynthesis of cannabinoid products		Canada	Inmed Pharmaceuticals Inc.	No	0	2020

Patent Number	Title	Resume	Country	Applicants	Granted	Citations	Year (Publication)
US2020224231A1	Production of cannabinoids in yeast using a fatty acid feedstock	Modification of the peroxisomal $\beta$ -oxidation in yeasts to provide an affordable and sustainable production of cannabinoids using vegetable oil or animal fat	USA	Levadura Biotechnology Inc.	No	0	2020
US10975379B2	Microorganisms and methods for producing cannabinoids, and cannabinoid derivatives	Proposes the recombinant expression of a geranyl pyrophosphate:olivetolic acid geranyltransferase (GOT) to produce cannabinoids molecules, precursors, or its derivatives	USA	University of California	Yes	0	2020
US2020165644A1	Production of cannabinoids in yeast	Heterologous synthesis of cannabinoids using 5% of fatty acids in genetically modified yeasts containing one or more genes responsible for the production of GPP producing; two or more olivetolic acid-producing genes; one or more cannabinoid precursor or cannabinoid producing genes; and one or more Hexanoyl-CoA producing genes	USA	Biomedican Inc.	No	0	2020
US2020165641A1	Bidirectional multi-enzymatic scaffolds for biosynthesizing of cannabinoids	Metabolic engineering of yeasts and bacteria using a complex system of 15 enzyme-encoding sequences for the production of a wide range of cannabinoids using glucose as carbon source <i>via</i> hexanoyl-CoA, malonyl-CoA, or mevalonate pathways	USA	Khona Pharms LLC	No	0	2020

Patent Number	Title	Resume	Country	Applicants	Granted	Citations	Year (Publication)
US2020080115A1	Cannabinoid Production by Synthetic In Vivo Means	Transformation of yeast cells with three or more vectors comprising for the enhanced GPP production, production of OTA and GOT activity	USA	Biotic Sciences LLC	No	0	2020
US2020071732A1	Production of Cannabinoids in Yeast	Genetic engineering of yeast cells with the inclusion of the GPP pathway genes, allowing a superior yield of cannabinoids and use of glucose as carbon source	USA	Librede Inc.	No	0	2020
US10954534B2	Production of Cannabinoidic Acid in Yeast	Claims the heterologous expression of cannabigerolic acid in yeasts and bacteria through the insertion of <i>Cannabis sativa</i> acyl-activating enzyme, mutant prenyltransferase, olivetolic synthase, olivetolic acid cyclase, and aromatic prenyltransferase	USA	Librede Inc.	Yes	0	2020

The analysis of the International Patent Classification (IPC) revealed that the introduction of foreign genes synthesizing transferases (C12N9/10) or lyases (C12N9/88) in vectors or expression systems specially adapted for *E. coli* (C12N15/70) are the main areas investigated (data not shown). Although not being able to perform post-translational modification as yeasts and higher eukaryotic cells, the superior growth rate, low nutritional requirement, higher yield, and the extensive genetic information of *E. coli* turns into a preferable host for tailoring new metabolic pathways for the industrial production of cannabinoids (161,182,183).

The technology of the cannabinoids biosynthesis was first protected by the University of Saskatchewan in association with the Natural Resources Council of Canada, where homologous, isolated, and/or purified sequences of *Cannabis sativa* alkanoyl-CoA synthetases, type III polyketide synthase, polyketide cyclase, aromatic prenyltransferase, and a cannabinoid-forming oxidocyclase were used as target genes for the cannabinoid production in *E. coli* and *Saccharomyces cerevisiae* systems (US9546362B2). According to the granted patent, carboxylic acids (C5-C20) and coenzyme-A are required as substrates, which directly impacts the cost of the final product. Similar plasmid vector configurations were later proposed with the addition of inducible galactose operons (US10392635B2), substitution of alkanoyl-CoA synthetases for prenol or isoprenol kinases (US10837031B2), or proposition of new host cells, such as *Lactobacillus paracasei* subsp. *paracasei* (EP3067058A1).

A recently granted patent by the American company Syntiva Therapeutics Inc. (US10801049B2) discloses the incorporation of phosphoglucose isomerase (*pgi*), glucose 6-phosphate dehydrogenase (*zwf*), and citrate synthase (*gltA*) genes in yeasts, which allows the heterologous production of hexanoate synthesis during the stationary phase using simple sugars. In addition, the overexpression of the long-chain fatty acid-CoA (*fadD*) ligase gene, responsible for the conversion of hexanoate into hexanoyl-CoA, also resulted in the silencing of the *fadE* gene associated with the degradation of this precursor. Such genetic modifications achieved costs inferior to US\$ 1.000 per kilogram of purified cannabinoid and significantly increased the yield of the process (184). This disruptive technology led to a significant leap in the number of filed patents, from 4 documents between 2014-2019 to 11 only in the last year (TABLE 3). The incremental changes proposed by these recent patents include the modification of the peroxisomal  $\beta$ -oxidation in yeasts to allow the use of fatty acids and affordable sources of vegetable and animal fat (US2020224231A1) and the inclusion of different pathways that allows the conversion of glucose into cannabinoids *via* acetoacetyl-CoA, malonyl-CoA, or mevalonate (US2020071732A1; US2020165641A1).

The survey revealed that only three countries detain the technology for the heterologous production of cannabinoids, being the United States the major contributor with 12 filled documents, followed by Canada and Italy with three and one documents, respectively. The presence of Canada in this selective group is supported by the Cannabis Act (185), a jurisdictional regulation that establishes production guidelines, licenses, and requirements for cannabis-derived products,

providing regulatory approval for both plant cultivation and the heterologous expression. USA and Italy, on the other hand, only have parameters defined by law regarding the cultivation and usage of the source material (i.e., cannabis plants with  $\Delta^9$ -THC content of 0.3% or 0.2-0.6%, respectively), leaving the microbial production under an unregulated ground (186,187). However, the allowance of cannabinoids prescription from a licensed healthcare provider (188,189) and the approval of the first CBD-containing drug (Epidiolex<sup>®</sup>) by the FDA in 2018 for treating severe seizures in patients above one year old (190) creates a prone environment for the development of biosynthetic cannabinoid industry in these countries. This statement is supported by the nature of the applicants in the prospected patents, which are majorly represented by private companies.

### **3 PROCESS DESIGN**

#### **3.1 PROCESS FLOWCHART**

A process flowchart was proposed to illustrate the downstream procedures involved during cannabinoids purification via heterologous expression in *S. cerevisiae* (FIGURE 6). It is considered that the engineered yeast produces  $\Delta^9$ -THCA. As aforementioned, the downstream unit operations' choices rely on microorganism specificities, and although this is a simplified model, it accounts for the main steps and operations towards the purification of cannabinoids on an industrial scale. With the development of pilot-scale experiments, kinetical and transport parameters can be better estimated for decision-making.



FIGURE 6 - Process flowchart listing the downstream operations required to purify  $\Delta^9$ -THCA from fermented broth and achieve high-quality  $\Delta^9$ -THC. FT: fermentation tank; DS: disc-stack centrifuge; ST: settling tank; BM: ball/beads mill; LS: liquid-liquid separator; MF: microfiltration unit; EV: falling film evaporator; DO: decarboxylation oven; GS: gas-liquid separator.

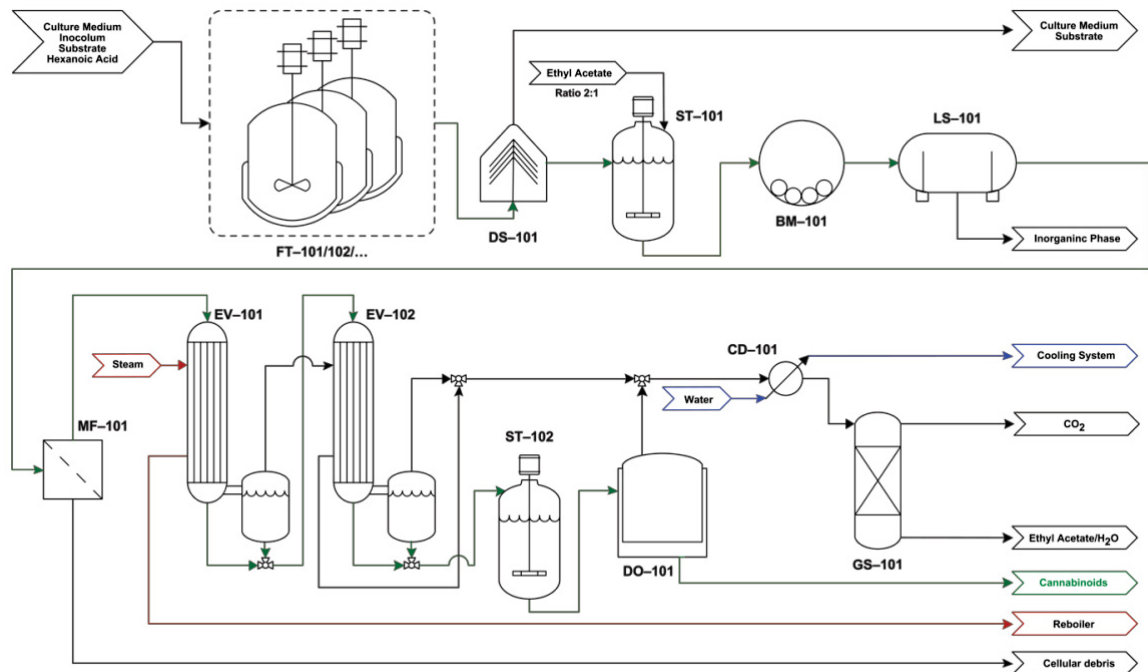

REFERENCE: The author (2022).

### 3.2 PROCESS DESCRIPTION

The separation procedures chosen were based on the works of Luo et al., 2019 and Zirpel et al., 2015, whereas the scaling up of the process were based on the works of Magalhães et al., 2017, and Poulos and Farnia, 2015, although some changes have been proposed to scale up the process. A staggered set of fermentation tanks (FT-101/102/...) is considered. After the fermentation time, the fermentation broth is sent to a disk-stack centrifuge (DS-101), responsible for the removal of culture medium and substrate not consumed during fermentation. Centrifugation is a suitable option due to *S. cerevisiae* high density ( $1.1 \text{ g/cm}^3$ ) and sedimentation radius ( $2.5 \mu\text{m}$ ) (178). Another option for this step is microfiltration, although the high-volume flow would require several membrane units to supply it. The cells can be dried in a low-temperature oven to remove the remaining water.

The cells are then sent to a settling tank (ST-101) in which ethyl acetate is used with a 2:1 ratio to resuspend the cells and subsequently promote liquid-liquid extraction. Ethyl acetate was chosen as the solvent due to its high capability to solubilize cannabinoids (193), but also because it is only partially soluble with water ( $8.3 \text{ g/L}$  at  $20 \text{ }^\circ\text{C}$ ), which allows the use of liquid-liquid separators during the downstream. As previously mentioned, ethanol is also suitable for

cannabinoids extraction, but its high-water solubility impairs the subsequent steps. Moreover, ethyl acetate is FDA approved for use in food as a flavor/fragrance enhancer and solvent (193).

The suspension is sent to a ball/bead mill (BM-01) to promote cell lysis. Since *S. cerevisiae* is disproved of a complex polysaccharide cell wall, the physical disruption should be enough, although chemical methods (e.g., detergents, enzymes, chelating agents, and/or solvents) can complement this process. Alternatively, high-pressure homogenizers can be used. In this stage, the cells are broken and the cannabinoids are dispersed in the medium. It is a relatively quick process on a laboratory scale ( $30\text{ s}^{-1}$  over 3 min) (13). The biphasic mixture passes through a liquid-liquid separator (LS-101), wherein the upper (organic) phase contains cannabinoids, ethyl acetate, and the lower phase is composed of water, ethyl acetate, and nutrients/culture medium. The lower phase is sent to the solvent recovery area.

The organic phase is forwarded to a microfiltration unit (MF-101) to remove cellular debris. For this operation, the filter membrane needs to have a pore size between 0.2 to 0.45  $\mu\text{m}$ . (13) used polyvinylidene difluoride (PVDF) membranes during its polishing steps prior to HPLC analysis.

The filtrate is then sent to a set of multiple effects falling film evaporators (EV-01/02) to remove part of the solvent and prepare the product for the decarboxylation step. Vacuum is used to boil the mixture in low temperatures, avoiding  $\Delta^9$ -THCA oxidation into CBNA and other secondary reactions (194). It is known that CBNA/CBN is formed during the long-time storage of cannabis (195), although its rate is reduced in the absence of oxygen and light (52). The vapor from the first effect is used as a heat duty stream to the second effect. Due to the high boiling points of cannabinoids, losses involved during evaporation are minimal. The vapor and condensate from the second effect are sent to a condenser (CD-101).

The concentrate is forwarded to a settling tank (ST-102) avoiding process discontinuity by upstream delays. The last step is to remove the residual solvent in the product and promote the decarboxylation of  $\Delta^9$ -THCA into  $\Delta^9$ -THC. For this step, a decarboxylation vacuum oven (DO-101) is proposed, in which the mixture is dispersed into trays with temperature close to 120  $^{\circ}\text{C}$  for up to one hour (196). As shown by Wang et al., 2016, it is possible to obtain pure  $\Delta^9$ -THC from  $\Delta^9$ -THCA by heating the extract to 110  $^{\circ}\text{C}$  for 40 min, under vacuum and absence of light. Even though no significant amount of CBN was detected, a relative loss in total molar concentration of 7.94% was noted, indicating that part of the reactant or product is being consumed by a secondary mechanism (e.g., a side reaction with an unstable intermediate and/or product).

After the decarboxylation step, the  $\Delta^9$ -THC extract is almost completely pure. The final product consists of  $\Delta^9$ -THC with residual ethyl acetate. As decarboxylation involves the loss of a carboxyl group, the molar mass of  $\Delta^9$ -THCA goes from 358.48 g/mol to 314.47 g/mol, causing a reduction in the mass of the final product by 12.3%.

As a complementary procedure, the concentrate can be sent to a fine separation involving chromatography, such as high-performance liquid chromatography (HPLC), counter-current chromatography (CCC), and centrifugal partition chromatography (CPC). These techniques show

high separation capacity and the possibility of scaling. CPC was chosen because of its advantages over CCC, such as a higher flow for the same volume. On a laboratory scale, 250 mL centrifugal partition chromatography has an ideal flow rate of 5-15 mL/min, while 250 mL counter flow chromatography has an ideal flow rate of 1 to 3 mL/min. On an industrial scale, 25 L counter-current chromatography has an ideal flow rate of 100 to 300 mL/min, whereas 25 L centrifugal partition chromatography has an ideal flow rate of 1000 to 3000 mL/min. This ensures greater productivity (due to higher flow and faster separation time), allowing the process to be scalable to up to tons per month (197). RotaChrom® developed an industrial scale CPC, the iCPC, which can deliver a flow rate of up to 2.5 L/min, achieving 50-500 kg of purified product per month (198). The final product is resuspended in anhydrous ethanol or formulated in capsules/pills as desired.

## 4 SENSITIVITY ANALYSIS WITH SIMBIOLOGY®

### 4.1 MODELING CONDITIONS AND CHARACTERIZATION

An *in silico* platform for  $\Delta^9$ -THCA biosynthesis through heterologous expression in *S. cerevisiae* is proposed based on Thomas et al., 2020, work's. The simulations were carried out for 40 h since a comparable *in vivo* culture will reach the stationary phase after most of the available carbon sources are depleted. Also, several process parameters of an *in vivo* cultivation (biomass turnover, generation cycle, feeding of glucose, pO<sub>2</sub>, pH, etc.) cannot be accounted by this given model.

During *in silico* design, the heterologous pathway is constructed as an unbranched linear metabolic pathway in *S. cerevisiae*. From the generation of simple building blocks like acetyl-CoA towards  $\Delta^9$ -THCA synthesis, the pathway is implemented concerning natural precursors. Throughout, energy and cofactor supply, as well as their respective usages, are tracked, starting with glycolysis over the citric acid cycle up to the cannabinoid pathway. Glucose uptake and metabolization via glycolysis are assumed to be the central pathway for the delivery of acetyl-CoA as a C2 building block for the mevalonate and fatty acid biosynthesis. Without consideration of compartmentalization in *S. cerevisiae*, direct cytosolic biotransformation of acetyl-CoA to olivetolic acid is assumed.

The extended kinetic model was constructed based on available kinetic parameters found in common enzyme reaction kinetics databases such as BRENDA (199) and SABIO-RK (200). All data were transferred to a model raised in MATLAB® version R2021b with the SimBiology extension (179). Where kinetic data was unavailable or scarce for *S. cerevisiae*, enzyme data of closely related species were considered and evaluated first before adding the parameters to the model.

For most reactions, simple Michaelis-Menten kinetics (Equation ( 1 )) was used and only implemented complex multi-substrate enzyme kinetics like ordered bi-bi kinetics (Equation ( 2 )), where one substrate could not be regarded as in excess compared with the other.

$$\frac{dC_i}{dt} = \frac{V_m[S]}{K_m + [S]} \quad (1)$$

$$\frac{dC_i}{dt} = \frac{V_m}{\frac{K_{sA}K_{mB}}{[A][B]} + \frac{K_{mA}}{[A]} + \frac{K_{mB}}{[B]} + 1} \quad (2)$$

In which  $dC_i$  is the concentration of the product “i”,  $V_m$  is the maximum rate ( $\text{mol.L}^{-1}.\text{s}^{-1}$ ),  $K_m$  is the Michaelis constant ( $\text{mol.L}^{-1}$ ),  $[S]$ ,  $[A]$ , and  $[B]$  are the concentrations of substrates ( $\text{mol.L}^{-1}$ ), and  $K_{sA}$  is the dissociation constant for substrate A.

$\Delta^9$ -THCA production was modeled starting from a simple glucose feed, passing glycolysis and the citric acid cycle to simulate energy supply. Product formation would then occur after simplified olivetolic acid, and mevalonate pathways provided olivetolic acid and geranyl pyrophosphate, respectively. Compartmentalization was mostly ignored for the sake of simplicity. Thus, it firstly results in a yeast cell compartment, containing all pathway reactions towards  $\Delta^9$ -THCA, and secondly a medium compartment, where nutrients, like glucose and hexanoic acid, are located (FIGURE 7).

FIGURE 7 - Model adopted during simulations in SimBiology toolbox representing the tetrahydrocannabinolic acid ( $\Delta^9$ -THCA) biosynthesis pathway in a heterologous host. Each compartment is delimited by its blue rounded rectangle. Species are represented by blue oval rectangles, whereas yellow circles represent reactions. Some species (e.g. glucose) are not shown in the model due to specific inputs in other sections.

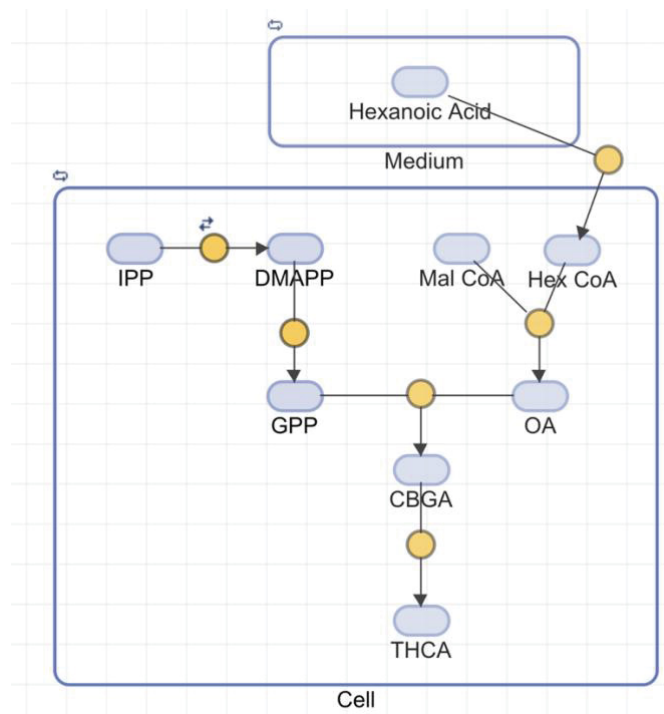

REFERENCE: The author (2022).

With  $\Delta^9$ -THCA as the apparent product output for the analysis, three key intermediates from mevalonate and olivetolic acid pathways were selected as inputs for a sensitivity analysis. The rate of formation of each compound was doubled in each scenario in order to reveal the dependence of these variables during cannabinoids biosynthesis in *S. cerevisiae*. In this regard, the established model may serve as a basis for the decision and a helpful guide to rational pathway optimizations.

## 4.2 SIMULATION WITH ORIGINAL PARAMETERS

The simulated intracellular concentrations of cannabinoid pathway intermediates and products over a simulation time of 40 h is showed in FIGURE 8. The obtained values are compared with Thomas et al., 2020, previous work results' in TABLE 4.

FIGURE 8 - Simulated intracellular concentrations of cannabinoid pathway intermediates and product over a simulation time of 40 h using SimBiology toolbox in MATLAB®.

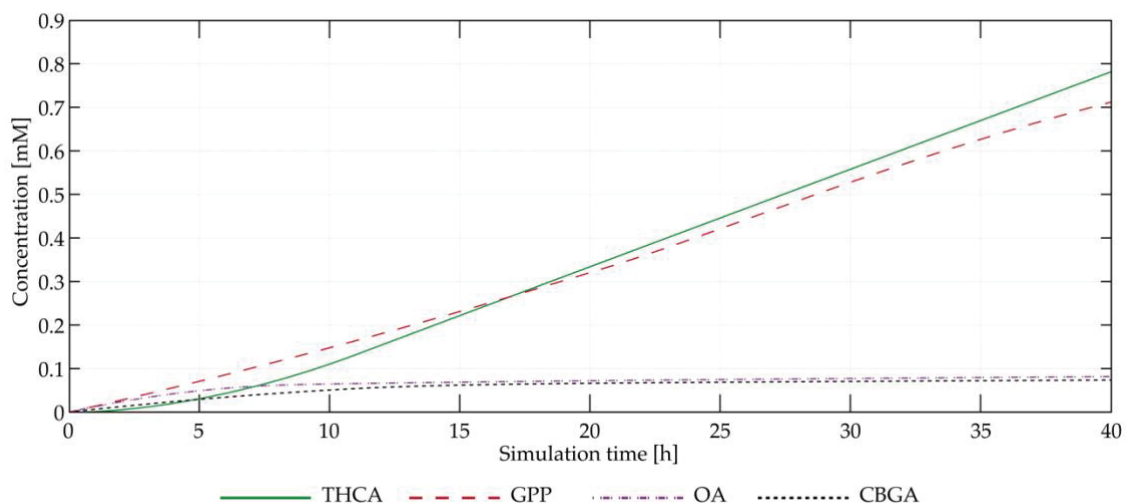

REFERENCE: The author (2022).

TABLE 4 - Simulated intracellular concentrations of cannabinoid pathway intermediates and product over a simulation time of 40 h compared with the work of Thomas et al., 2020.

Substance	Thomas et al., 2020 (mM)	This work (mM)	Abs. difference	Rel. difference (%)
THCA	0,827	0,780	0,046	-5,67
GPP	0,661	0,714	0,052	7,95
OA	0,075	0,081	0,006	8,42
CBGA	0,065	0,073	0,008	12,80

REFERENCE: The author (2022).

The difference between results are addressed especially for the parameters feeding steps during kinetic modeling of the system, accumulated errors during simplifications, and specificities of the chosen microorganism metabolism such as glucose uptake and metabolization via glycolysis.

The simulation revealed that olivetolic acid (OA) and cannabigerolic acid (CBGA) reach an intracellular non-toxic steady state. Geranyl pyrophosphate (GPP) and tetrahydrocannabinolic acid (THCA) are accumulated during simulation. These results indicate that both OA and CBGA are the bottleneck of THCA biosynthesis, whereas GPP is underused since it is accumulated over time.

### 4.3 SENSITIVITY ANALYSIS

#### 4.3.1 Increase in GPP rate of formation

The simulated intracellular concentrations of cannabinoid pathway intermediates and product with increased geranyl pyrophosphate (GPP) rate of formation (2x) over a simulation time of 40 h is showed in FIGURE 9, and the obtained values are contrasted with the original rate results in TABLE 5.

FIGURE 9 - Simulated intracellular concentrations of cannabinoid pathway intermediates and product with increased geranyl pyrophosphate (GPP) rate of formation (2x) over a simulation time of 40 h.

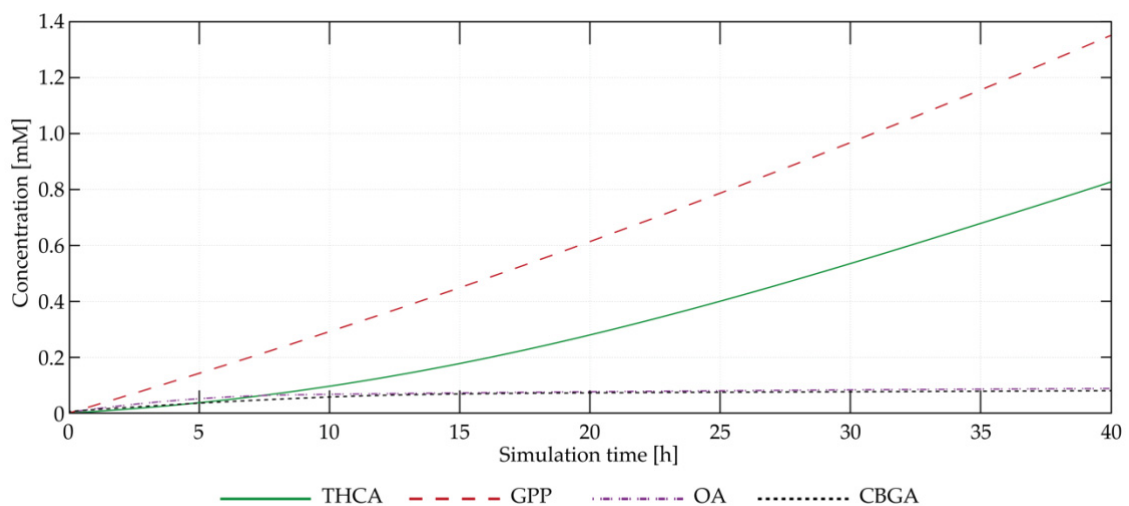

REFERENCE: The author (2022).

TABLE 5 - Simulated intracellular concentrations of cannabinoid pathway intermediates and product with increased geranyl pyrophosphate (GPP) rate of formation (2x) over a simulation time of 40 h.

Substance	Original rate (mM)	Increased GPP rate (mM)	Abs. difference	Rel. difference
THCA	0,782	0,827	0,045	5,76%
GPP	0,716	1,352	0,636	88,96%
OA	0,082	0,088	0,006	7,59%
CBGA	0,074	0,080	0,006	8,65%

REFERENCE: The author (2022).

The hypothesis that GPP is underused during the process is confirmed, since no relevant increase in THCA is noticed and, as expected, GPP is accumulated over time. This indicates that the GPP formation is too fast and not all GPP can be converted to CBGA, which can be explained either by too low OA supply or non-sufficient upstream conversion to THCA.

#### 4.3.2 Increase in OA rate of formation

The simulated intracellular concentrations of cannabinoid pathway intermediates and product with increased olivetolic acid (OA) rate of formation (2x) over a simulation time of 40 h is showed in FIGURE 10, and the obtained values are contrasted with the original rate results in TABLE 6.

FIGURE 10 - Simulated intracellular concentrations of cannabinoid pathway intermediates and product with increased olivetolic acid (OA) rate of formation (2x) over a simulation time of 40 h.

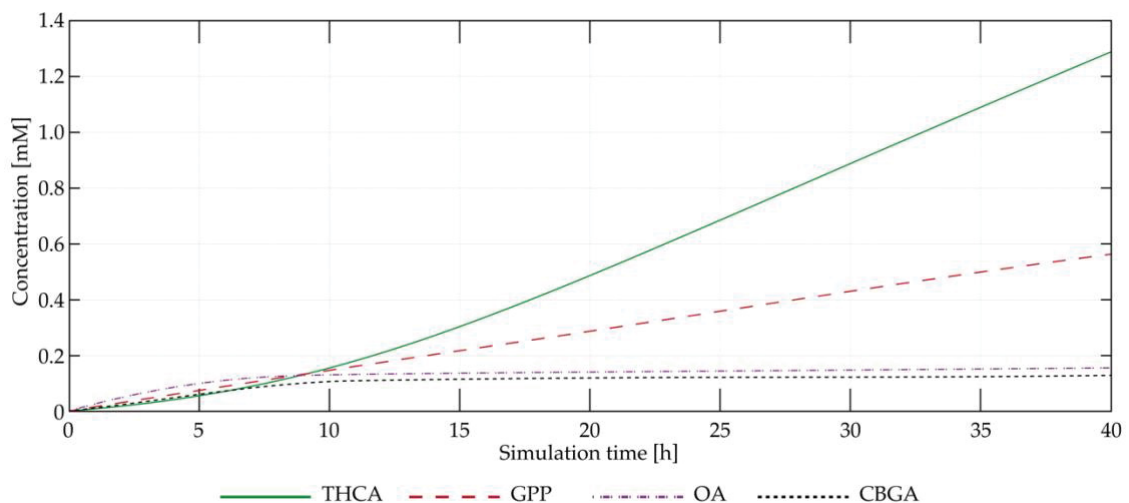

REFERENCE: The author (2022).



TABLE 6 - Simulated intracellular concentrations of cannabinoid pathway intermediates and product with increased olivetolic acid (OA) rate of formation (2x) over a simulation time of 40 h.

Substance	Original rate (mM)	Increased OA rate (mM)	Abs. difference	Rel. difference
THCA	0,782	1,288	0,505	64,66%
GPP	0,716	0,560	0,155	-21,73%
OA	0,082	0,156	0,074	90,69%
CBGA	0,074	0,129	0,055	75,06%

REFERENCE: The author (2022).

The increase in OA rate of formation showed a positive change in THCA final concentration. Again, olivetolic acid (OA) and cannabigerolic acid (CBGA) reach an intracellular non-toxic steady state, with higher final concentration than the original rate case. Also, the decrease in GPP final concentration agrees with the extra CBGA being synthesized thanks to the greater OA availability.

#### 4.3.3 Increase in CBGA rate of formation

The simulated intracellular concentrations of cannabinoid pathway intermediates and product with increased cannabigerolic acid (CBGA) rate of formation (2x) over a simulation time of 40 h is showed in FIGURE 11 and the obtained values are contrasted with the original rate results in TABLE 7.

FIGURE 11 - Simulated intracellular concentrations of cannabinoid pathway intermediates and product with increased cannabigerolic acid (CBGA) rate of formation (2x) over a simulation time of 40 h.

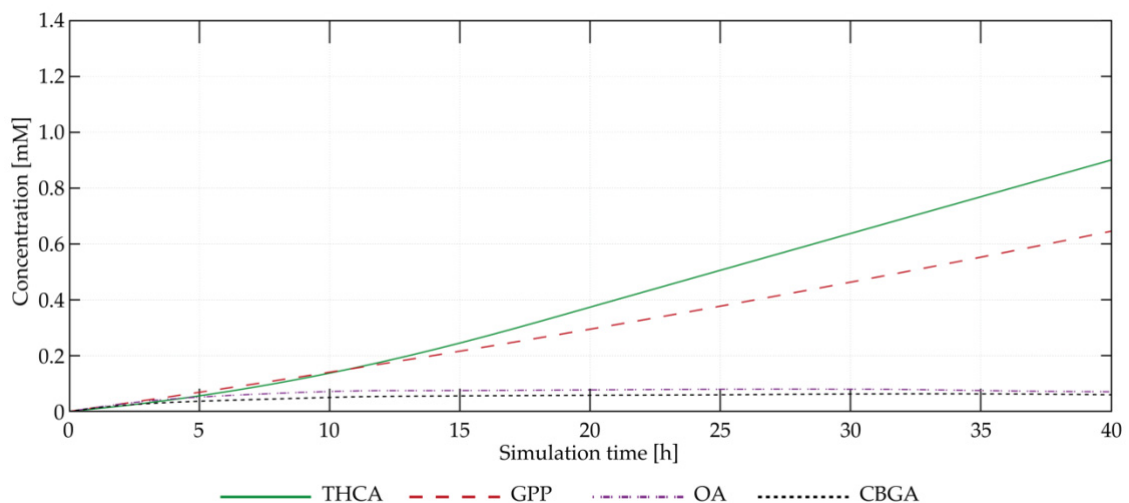

REFERENCE: The author (2022).



TABLE 7 - Simulated intracellular concentrations of cannabinoid pathway intermediates and product with increased cannabigerolic acid (CBGA) rate of formation (2x) over a simulation time of 40 h.

Substance	Original rate (mM)	Increased CBGA rate (mM)	Abs. difference	Rel. difference
THCA	0,782	0,900	0,1180	15,09%
GPP	0,716	0,645	0,0701	-9,79%
OA	0,082	0,070	0,0115	-14,08%
CBGA	0,074	0,065	0,0087	-11,79%

REFERENCE: The author (2022).

The increase in CBGA rate of formation showed a slightly positive change in THCA final concentration. The relative difference between CBGA and OA final concentration is smaller in the increased rate scenario than in the original, since CBGA increased rate has accelerated OA consumption. Although CBGA is being synthesized faster, the low availability of OA delimits its final output.

#### 4.4 OVERALL RESULTS

The overall results indicate that OA increased rate was the most impactful parameter during THCA biosynthesis sensitivity analysis, as shown in FIGURE 12.

FIGURE 12 - Normalized increase in THCA concentration during sensitivity analysis. The values were normalized in respect with the highest value (OA).

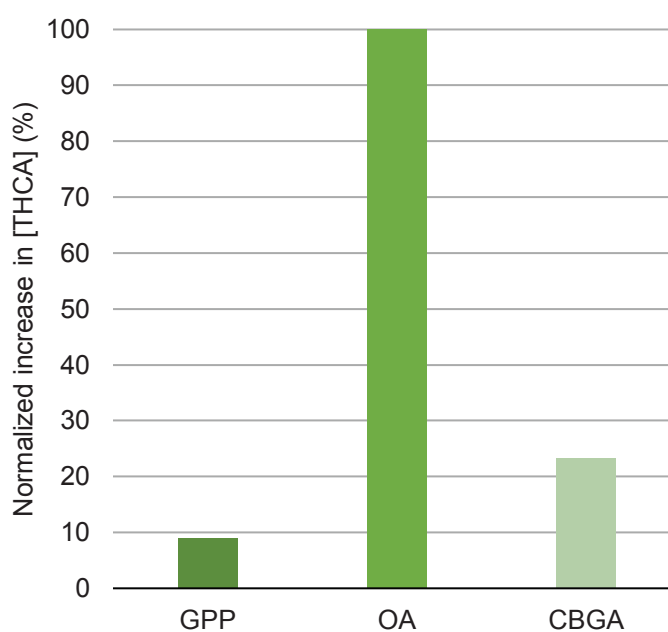

REFERENCE: The author (2022).

The low-availability of OA limits CBGA production, reducing the rate of formation of THCA. Thus, metabolic engineering should be addressed to OAC and OLS enzymes, but also hexanoic acid and hexanoyl-CoA uptake during previous steps.

The toxicity limitation of hexanoic acid (1 mM in *S. cerevisiae*) suggests the use of OA as a medium additive. Unfortunately, from its chemical and physical properties, OA is not well absorbed by yeast. It shows low chemical stability with high tendency to decarboxylation, and costs for synthesis are significantly higher than for hexanoic acid.

Finally, the low usage of GPP during all simulations scenarios grants permission for the continuous development of the OA pathway until it evens with GPP production.

## 5 CONCLUSIONS, FURTHER ANALYSES AND IMPROVEMENTS

The production of cannabinoids through heterologous expression in *S. cerevisiae* is feasible, although its low yields and metabolic bottlenecks adds complexity to scale up the process. Although fermentation can supply several cannabinoids, full-spectrum extracts (i.e., those with phytocannabinoids and secondary metabolites) are unlikely to be achieved, especially due to metabolic network complexity and microorganism expression limitations. In the future, it is important to analyze the limiting factors of cannabinoid production in the recombinant microorganism, and even reassess whether *S. cerevisiae* is the best candidate for this task.

To optimize the fermentative production of cannabinoids in recombinant microorganisms, different parameters need to be considered at genetic, metabolic, and technological levels. The first one refers to the expression of genes and pathways for the conversion of glucose into cannabinoids. The metabolic level is responsible for the better understanding of pathway interactions, allowing the characterization of metabolic bottlenecks to be further engineered and optimized. As noticed, the low acetyl-CoA and hexanoic acid availability for subsequent pathways are the main bottlenecks for the biosynthesis of  $\Delta^9$ -THCA in *S. cerevisiae*. The technological level refers to the downstream procedures needed to achieve high-purity cannabinoids on an industrial scale, avoiding unnecessary losses and providing a final product with accessible cost.

Nevertheless, cannabinoids fermentation is an exciting and brand-new niche arriving that can substantially change the availability of those compounds, providing a high-quality drug at a reasonable price, especially for non-common cannabinoids, such as C3 cannabinoids, novel cannabinoids, and analogs.

## 6 REFERENCES

1. HSC. Compassionate use act of 1996 [Internet]. State of California Health and Safety Code 1996 p. Chapter 6, Article 2. Available from: [https://leginfo.legislature.ca.gov/faces/codes\\_displaySection.xhtml?sectionNum=11362.5.&lawCode=HSC](https://leginfo.legislature.ca.gov/faces/codes_displaySection.xhtml?sectionNum=11362.5.&lawCode=HSC)
2. Canada G of. Marihuana Medical Access Regulations (SOR/2001-227) [Internet]. Canada Gazette 2001 p. 1–30. Available from: <http://laws-lois.justice.gc.ca/eng/regulations/SOR-2001-227/index.html>
3. State of Washington. Washington Initiative 502 (I502) [Internet]. 2012. Available from: [https://www.sos.wa.gov/\\_assets/elections/initiatives/i502.pdf](https://www.sos.wa.gov/_assets/elections/initiatives/i502.pdf)
4. State of Colorado. Amendment 64 [Internet]. 2012. Available from: [https://www.colorado.gov/pacific/sites/default/files/13 Amendment 64 LEGIS.pdf](https://www.colorado.gov/pacific/sites/default/files/13%20Amendment%2064%20LEGIS.pdf)
5. Parliament of Uruguay. Ley 19.172 [Internet]. 2013. Available from: [http://archivo.presidencia.gub.uy/sci/leyes/2013/12/cons\\_min\\_803.pdf](http://archivo.presidencia.gub.uy/sci/leyes/2013/12/cons_min_803.pdf)
6. Government of Canada. Cannabis Act (S.C. 2018, c. 16) [Internet]. 2018. Available from: <https://laws-lois.justice.gc.ca/eng/acts/c-24.5/>
7. Grand View Research. Cannabidiol market size, share and trends analysis report by source type (hemp, marijuana), by distribution channel (B2B, B2C), by end-use (medical, personal use), by region, and segment forecasts, 2021 - 2028. 2021.
8. Rosenthal E, Downs D. Beyond Buds: Marijuana Extracts Hash, Vaping, Dabbing, Edibles and Medicines. 2014.
9. Dolgin E. The bioengineering of cannabis. *Nature* [Internet]. 2019 Aug 28;572(7771):S5–7. Available from: <http://www.nature.com/articles/d41586-019-02525-4>
10. Shiponi S, Bernstein N. The Highs and Lows of P Supply in Medical Cannabis: Effects on Cannabinoids, the Ionome, and Morpho-Physiology. *Front Plant Sci* [Internet]. 2021 Jul 15;12. Available from: <https://www.frontiersin.org/articles/10.3389/fpls.2021.657323/full>
11. Summers HM, Sproul E, Quinn JC. The greenhouse gas emissions of indoor cannabis production in the United States. *Nat Sustain* [Internet]. 2021 Mar 8; Available from: <http://www.nature.com/articles/s41893-021-00691-w>
12. Zirpel B, Stehle F, Kayser O. Production of  $\Delta^9$ -tetrahydrocannabinolic acid from cannabigerolic acid by whole cells of *Pichia* (*Komagataella*) *pastoris* expressing  $\Delta^9$ -tetrahydrocannabinolic acid synthase from *Cannabis sativa* L. *Biotechnol Lett* [Internet]. 2015 Sep 21;37(9):1869–75. Available from: <http://link.springer.com/10.1007/s10529-015-1853-x>
13. Luo X, Reiter MA, d’Espaux L, Wong J, Denby CM, Lechner A, et al. Complete biosynthesis of cannabinoids and their unnatural analogues in yeast. *Nature*. 2019;567(7746):123–6.
14. Ben-Shabat S, Fride E, Sheskin T, Tamiri T, Rhee M-H, Vogel Z, et al. An entourage effect: inactive endogenous fatty acid glycerol esters enhance 2-arachidonoyl-glycerol cannabinoid activity. *Eur J Pharmacol* [Internet]. 1998 Jul;353(1):23–31. Available from: <https://linkinghub.elsevier.com/retrieve/pii/S0014299998003926>
15. Gallily R, Yekhtin Z, Hanuš LO. Overcoming the Bell-Shaped Dose-Response of Cannabidiol by Using  $\Delta^9$ -Cannabis  $\Delta^9$ -Extract Enriched in Cannabidiol. *Pharmacol & Pharm* [Internet]. 2015;06(02):75–85. Available from: <http://www.scirp.org/journal/doi.aspx?DOI=10.4236/pp.2015.62010>
16. Johnson JR, Burnell-Nugent M, Lossignol D, Ganæe-Motan ED, Potts R, Fallon MT. Multicenter, Double-Blind, Randomized, Placebo-Controlled, Parallel-Group Study of the Efficacy, Safety, and Tolerability of THC:CBD Extract and THC Extract in Patients with Intractable Cancer-Related Pain. *J Pain Symptom Manage* [Internet]. 2010 Feb;39(2):167–79. Available from: <https://linkinghub.elsevier.com/retrieve/pii/S0885392409007878>
17. Blasco-Benito S, Seijo-Vila M, Caro-Villalobos M, Tundidor I, Andradas C, García-Taboada E, et al. Appraising the “entourage effect”: Antitumor action of a pure cannabinoid versus a botanical drug preparation in preclinical models of breast cancer. *Biochem Pharmacol*. 2018;157(May):285–93.
18. Russo EB. Taming THC: Potential cannabis synergy and phytocannabinoid-terpenoid entourage effects. *Br J Pharmacol*. 2011;163(7):1344–64.

19. Quintão NL, da Silva GF, Antonialli CS, Rocha LW, Cechinel Filho V, Ciccio JF. Chemical composition and evaluation of the anti-hypernociceptive effect of the essential oil extracted from the leaves of *Ugni myricoides* on inflammatory and neuropathic models of pain in mice. *Planta Med* [Internet]. 2010 Sep;76(13):1411–8. Available from: <http://www.ncbi.nlm.nih.gov/pubmed/20157878>
20. Fidyk K, Fiedorowicz A, Strzdała L, Szumny A. B-Caryophyllene and B-Caryophyllene Oxide—Natural Compounds of Anticancer and Analgesic Properties. *Cancer Med*. 2016;5(10):3007–17.
21. Nascimento SS, Camargo EA, Desantana JM, Araújo AAS, Menezes PP, Lucca-Júnior W, et al. Linalool and linalool complexed in  $\beta$ -cyclodextrin produce anti-hyperalgesic activity and increase Fos protein expression in animal model for fibromyalgia. *Naunyn Schmiedebergs Arch Pharmacol*. 2014;387(10):935–42.
22. Rufino AT, Ribeiro M, Judas F, Salgueiro L, Lopes MC, Cavaleiro C, et al. Anti-inflammatory and Chondroprotective Activity of (+)- $\alpha$ -Pinene: Structural and Enantiomeric Selectivity. *J Nat Prod* [Internet]. 2014 Feb 28;77(2):264–9. Available from: <https://pubs.acs.org/doi/10.1021/np400828x>
23. Souza MC, Siani AC, Ramos MFS, Menezes-de-Lima OJ, Henriques MGMO. Evaluation of anti-inflammatory activity of essential oils from two Asteraceae species. *Pharmazie* [Internet]. 2003 Aug;58(8):582–6. Available from: <http://www.ncbi.nlm.nih.gov/pubmed/12967039>
24. Lei Y, Fu P, Jun X, Cheng P. Pharmacological Properties of Geraniol - A Review. *Planta Med* [Internet]. 2019 Jan;85(1):48–55. Available from: <http://www.ncbi.nlm.nih.gov/pubmed/30308694>
25. Mukhtar YM, Adu-Frimpong M, Xu X, Yu J. Biochemical significance of limonene and its metabolites: future prospects for designing and developing highly potent anticancer drugs. *Biosci Rep* [Internet]. 2018;38(6). Available from: <http://www.ncbi.nlm.nih.gov/pubmed/30287506>
26. Valente J, Zuzarte M, Gonçalves MJ, Lopes MC, Cavaleiro C, Salgueiro L, et al. Antifungal, antioxidant and anti-inflammatory activities of *Oenanthe crocata* L. essential oil. *Food Chem Toxicol*. 2013;62:349–54.
27. Takayama C, De-Faria FM, de Almeida ACA, Valim-Araújo D de A e O, Rehen CS, Dunder RJ, et al. Gastroprotective and ulcer healing effects of essential oil from *Hyptis spicigera* Lam. (Lamiaceae). *J Ethnopharmacol* [Internet]. 2011 Apr 26;135(1):147–55. Available from: <http://www.ncbi.nlm.nih.gov/pubmed/21396435>
28. Tambe Y, Tsujiuchi H, Honda G, Ikeshiro Y, Tanaka S. Gastric cytoprotection of the non-steroidal anti-inflammatory sesquiterpene, beta-caryophyllene. *Planta Med* [Internet]. 1996 Oct;62(5):469–70. Available from: <http://www.ncbi.nlm.nih.gov/pubmed/9005452>
29. de Souza MC, Vieira AJ, Beserra FP, Pellizzon CH, Nóbrega RH, Rozza AL. Gastroprotective effect of limonene in rats: Influence on oxidative stress, inflammation and gene expression. *Phytomedicine* [Internet]. 2019 Feb;53:37–42. Available from: <http://www.ncbi.nlm.nih.gov/pubmed/30668410>
30. Satou T, Kasuya H, Maeda K, Koike K. Daily inhalation of  $\alpha$ -pinene in mice: effects on behavior and organ accumulation. *Phytother Res* [Internet]. 2014 Sep;28(9):1284–7. Available from: <http://www.ncbi.nlm.nih.gov/pubmed/25340185>
31. Bahi A, Al Mansouri S, Al Memari E, Al Ameri M, Nurulain SM, Ojha S.  $\beta$ -Caryophyllene, a CB2 receptor agonist produces multiple behavioral changes relevant to anxiety and depression in mice. *Physiol Behav* [Internet]. 2014 Aug;135:119–24. Available from: <http://www.ncbi.nlm.nih.gov/pubmed/24930711>
32. Zhang L-L, Yang Z-Y, Fan G, Ren J-N, Yin K-J, Pan S-Y. Antidepressant-like Effect of *Citrus sinensis* (L.) Osbeck Essential Oil and Its Main Component Limonene on Mice. *J Agric Food Chem* [Internet]. 2019 Dec 18;67(50):13817–28. Available from: <http://www.ncbi.nlm.nih.gov/pubmed/30905156>
33. Lima NGPB, De Sousa DP, Pimenta FCF, Alves MF, De Souza FS, Macedo RO, et al. Anxiolytic-like activity and GC-MS analysis of (R)-(+)-limonene fragrance, a natural compound found in foods and plants. *Pharmacol Biochem Behav* [Internet]. 2013 Jan;103(3):450–4. Available from: <http://www.ncbi.nlm.nih.gov/pubmed/22995322>
34. Souto-Maior FN, De Carvalho FLD, De Moraes LCLS, Netto SM, De Sousa DP, De Almeida RN. Anxiolytic-like effects of inhaled linalool oxide in experimental mouse anxiety models. *Pharmacol Biochem Behav*. 2011;100(2):259–63.

35. Guzmán-Gutiérrez SL, Bonilla-Jaime H, Gómez-Cansino R, Reyes-Chilpa R. Linalool and  $\beta$ -pinene exert their antidepressant-like activity through the monoaminergic pathway. *Life Sci*. 2015;128:24–9.
36. Matsuo AL, Figueiredo CR, Arruda DC, Pereira F V, Scutti JAB, Massaoka MH, et al.  $\alpha$ -Pinene isolated from *Schinus terebinthifolius* Raddi (Anacardiaceae) induces apoptosis and confers antimetastatic protection in a melanoma model. *Biochem Biophys Res Commun* [Internet]. 2011 Jul 29;411(2):449–54. Available from: <http://www.ncbi.nlm.nih.gov/pubmed/21756878>
37. Cho M, So I, Chun JN, Jeon J-H. The antitumor effects of geraniol: Modulation of cancer hallmark pathways (Review). *Int J Oncol* [Internet]. 2016 May;48(5):1772–82. Available from: <http://www.ncbi.nlm.nih.gov/pubmed/26983575>
38. Katsuyama S, Mizoguchi H, Kuwahata H, Komatsu T, Nagaoka K, Nakamura H, et al. Involvement of peripheral cannabinoid and opioid receptors in  $\beta$ -caryophyllene-induced antinociception. *Eur J Pain* [Internet]. 2013 May;17(5):664–75. Available from: <http://www.ncbi.nlm.nih.gov/pubmed/23138934>
39. Rao VS, Menezes AM, Viana GS. Effect of myrcene on nociception in mice. *J Pharm Pharmacol* [Internet]. 1990 Dec;42(12):877–8. Available from: <http://www.ncbi.nlm.nih.gov/pubmed/1983154>
40. Souto-Maior FN, Da Fonsêca DV, Salgado PRR, Monte L de O, De Sousa DP, De Almeida RN. Antinociceptive and anticonvulsant effects of the monoterpene linalool oxide. *Pharm Biol*. 2017;55(1):63–7.
41. Machado K da C, Islam MT, Ali ES, Rouf R, Uddin SJ, Dev S, et al. A systematic review on the neuroprotective perspectives of beta-caryophyllene. *Phytother Res* [Internet]. 2018 Dec;32(12):2376–88. Available from: <http://www.ncbi.nlm.nih.gov/pubmed/30281175>
42. Ciftci O, Oztanir MN, Cetin A. Neuroprotective effects of  $\beta$ -myrcene following global cerebral ischemia/reperfusion-mediated oxidative and neuronal damage in a C57BL/J6 mouse. *Neurochem Res* [Internet]. 2014 Sep;39(9):1717–23. Available from: <http://www.ncbi.nlm.nih.gov/pubmed/24972849>
43. Shin M, Liu QF, Choi B, Shin C, Lee B, Yuan C, et al. Neuroprotective Effects of Limonene (+) against A $\beta$ 42-Induced Neurotoxicity in a *Drosophila* Model of Alzheimer's Disease. *Biol Pharm Bull* [Internet]. 2020 Mar 1;43(3):409–17. Available from: <http://www.ncbi.nlm.nih.gov/pubmed/31875578>
44. Xu P, Wang K, Lu C, Dong L, Gao L, Yan M, et al. The Protective Effect of Lavender Essential Oil and Its Main Component Linalool against the Cognitive Deficits Induced by D-Galactose and Aluminum Trichloride in Mice. *Evidence-based Complement Altern Med*. 2017;2017.
45. Do Vale TG, Furtado EC, Santos JG, Viana GSB. Central effects of citral, myrcene and limonene, constituents of essential oil chemotypes from *Lippia alba* (mill.) N.E. Brown. *Phytomedicine*. 2002;9(8):709–14.
46. Gastón MS, Cid MP, Vázquez AM, Decarlini MF, Demmel GI, Rossi LI, et al. Sedative effect of central administration of *Coriandrum sativum* essential oil and its major component linalool in neonatal chicks. *Pharm Biol*. 2016;54(10):1954–61.
47. Ito K, Ito M. The sedative effect of inhaled terpinolene in mice and its structure-activity relationships. *J Nat Med*. 2013;67(4):833–7.
48. Cavaleiro C, Salgueiro L, Gonçalves M-J, Hrimpeng K, Pinto J, Pinto E. Antifungal activity of the essential oil of *Angelica major* against *Candida*, *Cryptococcus*, *Aspergillus* and dermatophyte species. *J Nat Med* [Internet]. 2015 Apr;69(2):241–8. Available from: <http://www.ncbi.nlm.nih.gov/pubmed/25576097>
49. Pinto Â V, de Oliveira JC, Costa de Medeiros CA, Silva SL, Pereira FO. Potentiation of antifungal activity of terbinafine by dihydrojasnone and terpinolene against dermatophytes. *Lett Appl Microbiol* [Internet]. 2020 Aug 13; Available from: <http://www.ncbi.nlm.nih.gov/pubmed/32790923>
50. Di Marzo V, Bifulco M, De Petrocellis L. The endocannabinoid system and its therapeutic exploitation. *Nat Rev Drug Discov*. 2004;3(9):771–84.
51. ElSohly M, Gul W. Constituents of *Cannabis sativa*. In: *Handbook of Cannabis*. 2015. p. 115–36.
52. Wang M, Wang Y-H, Avula B, Radwan MM, Wanas AS, van Antwerp J, et al. Decarboxylation Study of Acidic Cannabinoids: A Novel Approach Using Ultra-High-Performance Supercritical Fluid Chromatography/Photodiode Array-Mass Spectrometry. *Cannabis Cannabinoid*



- Res [Internet]. 2016 Dec;1(1):262–71. Available from: <http://www.liebertpub.com/doi/10.1089/can.2016.0020>
53. Hanuš LO, Meyer SM, Muñoz E, Tagliabue S, Scafati O, Appendino G. Phytocannabinoids: a unified critical inventory. *Nat Prod Rep* [Internet]. 2016;33(12):1357–92. Available from: <http://xlink.rsc.org/?DOI=C6NP00074F>
  54. Pisanti S, Malfitano AM, Ciaglia E, Lamberti A, Ranieri R, Cuomo G, et al. Cannabidiol: State of the art and new challenges for therapeutic applications. *Pharmacol Ther*. 2017;175:133–50.
  55. Rosenthaler S, Pöhn B, Kolmanz C, Nguyen Huu C, Krewenka C, Huber A, et al. Differences in receptor binding affinity of several phytocannabinoids do not explain their effects on neural cell cultures. *Neurotoxicol Teratol* [Internet]. 2014 Nov;46:49–56. Available from: <https://linkinghub.elsevier.com/retrieve/pii/S089203621400172X>
  56. Cristino L, Bisogno T, Di Marzo V. Cannabinoids and the expanded endocannabinoid system in neurological disorders. *Nat Rev Neurol* [Internet]. 2020 Jan 12;16(1):9–29. Available from: <http://www.nature.com/articles/s41582-019-0284-z>
  57. Pacher P, Bátkai S, Kunos G. The Endocannabinoid System as an Emerging Target of Pharmacotherapy. *Pharmacol Rev* [Internet]. 2006 Sep;58(3):389–462. Available from: <http://pharmrev.aspetjournals.org/lookup/doi/10.1124/pr.58.3.2>
  58. Mackie K. Mechanisms of CB1 receptor signaling: endocannabinoid modulation of synaptic strength. *Int J Obes* [Internet]. 2006 Apr 29;30(S1):S19–23. Available from: <http://www.nature.com/articles/0803273>
  59. Pertwee RG. The diverse CB 1 and CB 2 receptor pharmacology of three plant cannabinoids:  $\Delta^9$ -tetrahydrocannabinol, cannabidiol and  $\Delta^9$ -tetrahydrocannabivarin. *Br J Pharmacol* [Internet]. 2008 Jan;153(2):199–215. Available from: <http://doi.wiley.com/10.1038/sj.bjp.0707442>
  60. Pertwee RG, Thomas A, Stevenson LA, Ross RA, Varvel SA, Lichtman AH, et al. The psychoactive plant cannabinoid,  $\Delta^9$ -tetrahydrocannabinol, is antagonized by  $\Delta^8$ - and  $\Delta^9$ -tetrahydrocannabivarin in mice in vivo. *Br J Pharmacol* [Internet]. 2007 Mar;150(5):586–94. Available from: <http://doi.wiley.com/10.1038/sj.bjp.0707124>
  61. Fellermeier M, Eisenreich W, Bacher A, Zenk MH. Biosynthesis of cannabinoids. *Eur J Biochem* [Internet]. 2001 Mar 15;268(6):1596–604. Available from: <http://doi.wiley.com/10.1046/j.1432-1327.2001.02030.x>
  62. Degenhardt F, Stehle F, Kayser O. The Biosynthesis of Cannabinoids. In: *Handbook of Cannabis and Related Pathologies: Biology, Pharmacology, Diagnosis, and Treatment* [Internet]. Elsevier; 2017. p. 13–23. Available from: <https://linkinghub.elsevier.com/retrieve/pii/B9780128007563000028>
  63. Grotenhermen F. Pharmacokinetics and Pharmacodynamics of Cannabinoids. *Clin Pharmacokinet* [Internet]. 2003;42(4):327–60. Available from: <http://link.springer.com/10.2165/00003088-200342040-00003>
  64. Bruni N, Della Pepa C, Oliaro-Bosso S, Pessione E, Gastaldi D, Dosio F. Cannabinoid Delivery Systems for Pain and Inflammation Treatment. *Molecules* [Internet]. 2018 Sep 27;23(10):2478. Available from: <http://www.mdpi.com/1420-3049/23/10/2478>
  65. Russo E. Cannabinoids in the management of difficult to treat pain. *Ther Clin Risk Manag* [Internet]. 2008 Feb;Volume 4:245–59. Available from: <https://www.dovepress.com/cannabinoids-in-the-management-of-difficult-to-treat-pain-peer-reviewed-article-TCRM>
  66. Most J, Bryk M, Starowicz K. Cannabidiol for Pain Treatment: Focus on Pharmacology and Mechanism of Action. *Int J Mol Sci* [Internet]. 2020 Nov 23;21(22):8870. Available from: <https://www.mdpi.com/1422-0067/21/22/8870>
  67. Vecchio D, Varrasi C, Virgilio E, Spagarino A, Naldi P, Cantello R. Cannabinoids in multiple sclerosis: A neurophysiological analysis. *Acta Neurol Scand* [Internet]. 2020 Oct 21;142(4):333–8. Available from: <https://onlinelibrary.wiley.com/doi/10.1111/ane.13313>
  68. Wong H, Cairns BE. Cannabidiol, cannabiniol and their combinations act as peripheral analgesics in a rat model of myofascial pain. *Arch Oral Biol* [Internet]. 2019 Aug;104:33–9. Available from: <https://linkinghub.elsevier.com/retrieve/pii/S0003996919302249>
  69. Noyes R, Brunk SF, Avery DH, Canter A. The analgesic properties of delta-9-tetrahydrocannabinol and codeine. *Clin Pharmacol Ther* [Internet]. 1975 Jul;18(1):84–9. Available from: <http://doi.wiley.com/10.1002/cpt197518184>

70. Cooper ZD, Comer SD, Haney M. Comparison of the Analgesic Effects of Dronabinol and Smoked Marijuana in Daily Marijuana Smokers. *Neuropsychopharmacology* [Internet]. 2013 Sep 22;38(10):1984–92. Available from: <http://www.nature.com/articles/npp201397>
71. Cascio M, Gauson L, Stevenson L, Ross R, Pertwee R. Evidence that the plant cannabinoid cannabigerol is a highly potent  $\alpha$ 2-adrenoceptor agonist and moderately potent 5HT1A receptor antagonist. *Br J Pharmacol* [Internet]. 2010 Jan;159(1):129–41. Available from: <http://doi.wiley.com/10.1111/j.1476-5381.2009.00515.x>
72. Bolognini D, Costa B, Maione S, Comelli F, Marini P, Di Marzo V, et al. The plant cannabinoid  $\Delta$ 9-tetrahydrocannabivarin can decrease signs of inflammation and inflammatory pain in mice. *Br J Pharmacol* [Internet]. 2010 Jun;160(3):677–87. Available from: <http://doi.wiley.com/10.1111/j.1476-5381.2010.00756.x>
73. Zagožen M, Čerenak A, Kreft S. Cannabigerol and cannabichromene in *Cannabis sativa* L. *Acta Pharm* [Internet]. 2021 Sep 1;71(3):355–64. Available from: <https://content.sciendo.com/view/journals/acph/71/3/article-p355.xml>
74. Davis WM, Hatoum NS. Neurobehavioral actions of cannabichromene and interactions with  $\Delta$ 9-tetrahydrocannabinol. *Gen Pharmacol Vasc Syst* [Internet]. 1983 Jan;14(2):247–52. Available from: <https://linkinghub.elsevier.com/retrieve/pii/0306362383900046>
75. Sofia RD, Vassar HB, Knobloch LC. Comparative analgesic activity of various naturally occurring cannabinoids in mice and rats. *Psychopharmacologia* [Internet]. 1975;40(4):285–95. Available from: <http://link.springer.com/10.1007/BF00421466>
76. Tudge L, Williams C, Cowen PJ, McCabe C. Neural Effects of Cannabinoid CB1 Neutral Antagonist Tetrahydrocannabivarin on Food Reward and Aversion in Healthy Volunteers. *Int J Neuropsychopharmacol* [Internet]. 2015 Apr;18(6). Available from: <https://academic.oup.com/ijnp/article-lookup/doi/10.1093/ijnp/pyu094>
77. Riedel G, Fadda P, McKillop-Smith S, Pertwee RG, Platt B, Robinson L. Synthetic and plant-derived cannabinoid receptor antagonists show hypophagic properties in fasted and non-fasted mice. *Br J Pharmacol* [Internet]. 2009 Mar 31;156(7):1154–66. Available from: <http://doi.wiley.com/10.1111/j.1476-5381.2008.00107.x>
78. Yang Y, Huynh N, Dumesny C, Wang K, He H, Nikfarjam M. Cannabinoids Inhibited Pancreatic Cancer via P-21 Activated Kinase 1 Mediated Pathway. *Int J Mol Sci* [Internet]. 2020 Oct 28;21(21):8035. Available from: <https://www.mdpi.com/1422-0067/21/21/8035>
79. Seltzer ES, Watters AK, MacKenzie D, Granat LM, Zhang D. Cannabidiol (CBD) as a Promising Anti-Cancer Drug. *Cancers (Basel)* [Internet]. 2020 Oct 30;12(11):3203. Available from: <https://www.mdpi.com/2072-6694/12/11/3203>
80. Anis O, Vinayaka AC, Shalev N, Namdar D, Nadarajan S, Anil SM, et al. Cannabis-Derived Compounds Cannabichromene and  $\Delta$ 9-Tetrahydrocannabinol Interact and Exhibit Cytotoxic Activity against Urothelial Cell Carcinoma Correlated with Inhibition of Cell Migration and Cytoskeleton Organization. *Molecules* [Internet]. 2021 Jan 17;26(2):465. Available from: <https://www.mdpi.com/1420-3049/26/2/465>
81. De Petrocellis L, Ligresti A, Moriello AS, Allarà M, Bisogno T, Petrosino S, et al. Effects of cannabinoids and cannabinoid-enriched Cannabis extracts on TRP channels and endocannabinoid metabolic enzymes. *Br J Pharmacol* [Internet]. 2011 Aug;163(7):1479–94. Available from: <http://doi.wiley.com/10.1111/j.1476-5381.2010.01166.x>
82. Baek SH, Kim YO, Kwag JS, Choi KE, Jung WY, Han DS. Boron trifluoride etherate on silica-A modified lewis acid reagent (VII). Antitumor activity of cannabigerol against human oral epitheloid carcinoma cells. *Arch Pharm Res* [Internet]. 1998 Jun;21(3):353–6. Available from: <http://link.springer.com/10.1007/BF02975301>
83. Ligresti A, Moriello AS, Starowicz K, Matias I, Pisanti S, De Petrocellis L, et al. Antitumor Activity of Plant Cannabinoids with Emphasis on the Effect of Cannabidiol on Human Breast Carcinoma. *J Pharmacol Exp Ther* [Internet]. 2006 Sep;318(3):1375–87. Available from: <http://jpet.aspetjournals.org/lookup/doi/10.1124/jpet.106.105247>
84. Schoeman R, Beukes N, Frost C. Cannabinoid Combination Induces Cytoplasmic Vacuolation in MCF-7 Breast Cancer Cells. *Molecules* [Internet]. 2020 Oct 14;25(20):4682. Available from: <https://www.mdpi.com/1420-3049/25/20/4682>
85. Holland ML, Panetta JA, Hoskins JM, Bebawy M, Roufogalis BD, Allen JD, et al. The effects of cannabinoids on P-glycoprotein transport and expression in multidrug resistant cells. *Biochem*



- Pharmacol [Internet]. 2006 Apr;71(8):1146–54. Available from: <https://linkinghub.elsevier.com/retrieve/pii/S0006295206000037>
86. Abame MA, He Y, Wu S, Xie Z, Zhang J, Gong X, et al. Chronic administration of synthetic cannabidiol induces antidepressant effects involving modulation of serotonin and noradrenaline levels in the hippocampus. *Neurosci Lett* [Internet]. 2021 Jan;744:135594. Available from: <https://linkinghub.elsevier.com/retrieve/pii/S0304394020308648>
87. Chaves YC, Genaro K, Crippa JA, da Cunha JM, Zanoveli JM. Cannabidiol induces antidepressant and anxiolytic-like effects in experimental type-1 diabetic animals by multiple sites of action. *Metab Brain Dis* [Internet]. 2021 Jan 19; Available from: <http://link.springer.com/10.1007/s11011-020-00667-3>
88. Campos AC, Moreira FA, Gomes FV, Del Bel EA, Guimarães FS. Multiple mechanisms involved in the large-spectrum therapeutic potential of cannabidiol in psychiatric disorders. *Philos Trans R Soc B Biol Sci* [Internet]. 2012 Dec 5;367(1607):3364–78. Available from: <https://royalsocietypublishing.org/doi/10.1098/rstb.2011.0389>
89. El-Alfy AT, Ivey K, Robinson K, Ahmed S, Radwan M, Slade D, et al. Antidepressant-like effect of  $\Delta^9$ -tetrahydrocannabinol and other cannabinoids isolated from *Cannabis sativa* L. *Pharmacol Biochem Behav* [Internet]. 2010 Jun;95(4):434–42. Available from: <https://linkinghub.elsevier.com/retrieve/pii/S0091305710000730>
90. Lehmann C, Fisher NB, Tugwell B, Szczesniak A, Kelly M, Zhou J. Experimental cannabidiol treatment reduces early pancreatic inflammation in type 1 diabetes. *Clin Hemorheol Microcirc* [Internet]. 2017 Feb 2;64(4):655–62. Available from: <https://www.medra.org/servlet/aliasResolver?alias=iospress&doi=10.3233/CH-168021>
91. Burstein S. Cannabidiol (CBD) and its analogs: a review of their effects on inflammation. *Bioorg Med Chem* [Internet]. 2015 Apr;23(7):1377–85. Available from: <https://linkinghub.elsevier.com/retrieve/pii/S0968089615000838>
92. Zurier RB, Burstein SH. Cannabinoids, inflammation, and fibrosis. *FASEB J*. 2016;30(11):3682–9.
93. Duane Sofia R, Nalepa SD, Vassar HB, Knobloch LC. Comparative anti-phlogistic activity of  $\Delta^9$ -tetrahydrocannabinol, hydrocortisone and aspirin in various rat paw edema models. *Life Sci* [Internet]. 1974 Jul;15(2):251–60. Available from: <https://linkinghub.elsevier.com/retrieve/pii/0024320574902148>
94. Borrelli F, Fasolino I, Romano B, Capasso R, Maiello F, Coppola D, et al. Beneficial effect of the non-psychoactive plant cannabinoid cannabigerol on experimental inflammatory bowel disease. *Biochem Pharmacol* [Internet]. 2013 May;85(9):1306–16. Available from: <https://linkinghub.elsevier.com/retrieve/pii/S0006295213000543>
95. TURNER CE, ELSOHLY MA. Biological Activity of Cannabichromene, its Homologs and Isomers. *J Clin Pharmacol* [Internet]. 1981 Aug 9;21(S1):283S–291S. Available from: <http://doi.wiley.com/10.1002/j.1552-4604.1981.tb02606.x>
96. Izzo AA, Capasso R, Aviello G, Borrelli F, Romano B, Piscitelli F, et al. Inhibitory effect of cannabichromene, a major non-psychoactive cannabinoid extracted from *Cannabis sativa*, on inflammation-induced hypermotility in mice. *Br J Pharmacol* [Internet]. 2012 Jun;166(4):1444–60. Available from: <http://doi.wiley.com/10.1111/j.1476-5381.2012.01879.x>
97. Wirth PW, Sue Watson E, ElSohly M, Turner CE, Murphy JC. Anti-inflammatory properties of cannabichromene. *Life Sci* [Internet]. 1980 Jun;26(23):1991–5. Available from: <https://linkinghub.elsevier.com/retrieve/pii/0024320580906311>
98. Gu Z, Singh S, Niyogi RG, Lamont GJ, Wang H, Lamont RJ, et al. Marijuana-Derived Cannabinoids Trigger a CB2/PI3K Axis of Suppression of the Innate Response to Oral Pathogens. *Front Immunol* [Internet]. 2019 Oct 15;10. Available from: <https://www.frontiersin.org/article/10.3389/fimmu.2019.02288/full>
99. Durst R, Danenberg H, Gallily R, Mechoulam R, Meir K, Grad E, et al. Cannabidiol, a nonpsychoactive *Cannabis* constituent, protects against myocardial ischemic reperfusion injury. *Am J Physiol Circ Physiol* [Internet]. 2007 Dec;293(6):H3602–7. Available from: <https://www.physiology.org/doi/10.1152/ajpheart.00098.2007>
100. Waldman M, Hochhauser E, Fishbein M, Aravot D, Shainberg A, Sarne Y. An ultra-low dose of tetrahydrocannabinol provides cardioprotection. *Biochem Pharmacol* [Internet]. 2013 Jun;85(11):1626–33. Available from: <https://linkinghub.elsevier.com/retrieve/pii/S0006295213001950>

101. van Klingerden B, ten Ham M. Antibacterial activity of  $\Delta^9$ -tetrahydrocannabinol and cannabidiol. *Antonie Van Leeuwenhoek* [Internet]. 1976 Mar;42(1–2):9–12. Available from: <http://link.springer.com/10.1007/BF00399444>
102. Appendino G, Gibbons S, Giana A, Pagani A, Grassi G, Stavri M, et al. Antibacterial Cannabinoids from *Cannabis sativa*: A Structure–Activity Study. *J Nat Prod* [Internet]. 2008 Aug;71(8):1427–30. Available from: <https://pubs.acs.org/doi/10.1021/np8002673>
103. Farha MA, El-Halfawy OM, Gale RT, MacNair CR, Carfrae LA, Zhang X, et al. Uncovering the Hidden Antibiotic Potential of Cannabis. *ACS Infect Dis* [Internet]. 2020 Mar 13;6(3):338–46. Available from: <https://pubs.acs.org/doi/10.1021/acsinfectdis.9b00419>
104. Elsohly HN, Turner CE, Clark AM, Elsohly MA. Synthesis and Antimicrobial Activities of Certain Cannabichromene and Cannabigerol Related Compounds. *J Pharm Sci* [Internet]. 1982 Dec;71(12):1319–23. Available from: <https://linkinghub.elsevier.com/retrieve/pii/S0022354915444211>
105. Rock EM, Parker LA. Synergy between cannabidiol, cannabidiolic acid, and  $\Delta^9$ -tetrahydrocannabinol in the regulation of emesis in the *Suncus murinus* (house musk shrew). *Behav Neurosci* [Internet]. 2015;129(3):368–70. Available from: <http://doi.apa.org/getdoi.cfm?doi=10.1037/bne0000057>
106. Sallan SE, Zinberg NE, Frei E. Antiemetic Effect of Delta-9-Tetrahydrocannabinol in Patients Receiving Cancer Chemotherapy. *N Engl J Med* [Internet]. 1975 Oct 16;293(16):795–7. Available from: <http://www.nejm.org/doi/abs/10.1056/NEJM197510162931603>
107. Rock EM, Goodwin JM, Limebeer CL, Breuer A, Pertwee RG, Mechoulam R, et al. Interaction between non-psychotropic cannabinoids in marijuana: effect of cannabigerol (CBG) on the anti-nausea or anti-emetic effects of cannabidiol (CBD) in rats and shrews. *Psychopharmacology (Berl)* [Internet]. 2011 Jun 18;215(3):505–12. Available from: <http://link.springer.com/10.1007/s00213-010-2157-4>
108. Rock EM, Sticht MA, Duncan M, Stott C, Parker LA. Evaluation of the potential of the phytocannabinoids, cannabidivarin (CBDV) and  $\Delta^9$ -tetrahydrocannabivarin (THCV), to produce CB1 receptor inverse agonism symptoms of nausea in rats. *Br J Pharmacol* [Internet]. 2013 Oct;170(3):671–8. Available from: <http://doi.wiley.com/10.1111/bph.12322>
109. Devinsky O, Marsh E, Friedman D, Thiele E, Laux L, Sullivan J, et al. Cannabidiol in patients with treatment-resistant epilepsy: an open-label interventional trial. *Lancet Neurol* [Internet]. 2016 Mar;15(3):270–8. Available from: <https://linkinghub.elsevier.com/retrieve/pii/S1474442215003798>
110. Devinsky O, Cilio MR, Cross H, Fernandez-Ruiz J, French J, Hill C, et al. Cannabidiol: Pharmacology and potential therapeutic role in epilepsy and other neuropsychiatric disorders. *Epilepsia* [Internet]. 2014 Jun;55(6):791–802. Available from: <http://doi.wiley.com/10.1111/epi.12631>
111. Corcoran ME, McCaughran JA, Wada JA. Acute antiepileptic effects of  $\Delta^9$ -tetrahydrocannabinol in rats with kindled seizures. *Exp Neurol* [Internet]. 1973 Aug;40(2):471–83. Available from: <https://linkinghub.elsevier.com/retrieve/pii/0014488673900885>
112. Hill AJ, Weston SE, Jones NA, Smith I, Bevan SA, Williamson EM, et al.  $\Delta^9$ -Tetrahydrocannabivarin suppresses in vitro epileptiform and in vivo seizure activity in adult rats. *Epilepsia* [Internet]. 2010 Feb 26;51(8):1522–32. Available from: <http://doi.wiley.com/10.1111/j.1528-1167.2010.02523.x>
113. Jarocka-Karpowicz I, Biernacki M, Wroński A, Gęgotek A, Skrzydlewska E. Cannabidiol Effects on Phospholipid Metabolism in Keratinocytes from Patients with Psoriasis Vulgaris. *Biomolecules* [Internet]. 2020 Feb 28;10(3):367. Available from: <https://www.mdpi.com/2218-273X/10/3/367>
114. Łuczaj W, Dobrzyńska I, Wroński A, Domingues MR, Domingues P, Skrzydlewska E. Cannabidiol-Mediated Changes to the Phospholipid Profile of UVB-Irradiated Keratinocytes from Psoriatic Patients. *Int J Mol Sci* [Internet]. 2020 Sep 9;21(18):6592. Available from: <https://www.mdpi.com/1422-0067/21/18/6592>
115. Wilkinson JD, Williamson EM. Cannabinoids inhibit human keratinocyte proliferation through a non-CB1/CB2 mechanism and have a potential therapeutic value in the treatment of psoriasis. *J Dermatol Sci* [Internet]. 2007 Feb;45(2):87–92. Available from: <https://linkinghub.elsevier.com/retrieve/pii/S092318110600315X>

116. Rohleder C, Müller JK, Lange B, Leweke FM. Cannabidiol as a Potential New Type of an Antipsychotic. A Critical Review of the Evidence. *Front Pharmacol* [Internet]. 2016 Nov 8;7. Available from: <http://journal.frontiersin.org/article/10.3389/fphar.2016.00422/full>
117. Davies C, Bhattacharyya S. Cannabidiol as a potential treatment for psychosis. *Ther Adv Psychopharmacol* [Internet]. 2019 Jan 8;9:204512531988191. Available from: <http://journals.sagepub.com/doi/10.1177/2045125319881916>
118. Cascio MG, Zamberletti E, Marini P, Parolaro D, Pertwee RG. The phytocannabinoid,  $\Delta^9$ -tetrahydrocannabinol, can act through 5-HT<sub>1A</sub> receptors to produce antipsychotic effects. *Br J Pharmacol* [Internet]. 2015 Mar;172(5):1305–18. Available from: <http://doi.wiley.com/10.1111/bph.13000>
119. Giacoppo S, Bramanti P, Mazzon E. Sativex in the management of multiple sclerosis-related spasticity: An overview of the last decade of clinical evaluation. *Mult Scler Relat Disord* [Internet]. 2017 Oct;17:22–31. Available from: <https://linkinghub.elsevier.com/retrieve/pii/S2211034817301487>
120. Marková J, Essner U, Akmaz B, Marinelli M, Trompke C, Lentschat A, et al. Sativex® as add-on therapy vs. further optimized first-line ANTispastics (SAVANT) in resistant multiple sclerosis spasticity: a double-blind, placebo-controlled randomised clinical trial. *Int J Neurosci* [Internet]. 2019 Feb 1;129(2):119–28. Available from: <https://www.tandfonline.com/doi/full/10.1080/00207454.2018.1481066>
121. Campos AC, Fogaça M V., Sonogo AB, Guimarães FS. Cannabidiol, neuroprotection and neuropsychiatric disorders. *Pharmacol Res* [Internet]. 2016 Oct;112:119–27. Available from: <https://linkinghub.elsevier.com/retrieve/pii/S1043661816000396>
122. Braidă D, Limonta V, Malabarba L, Zani A, Sala M. 5-HT<sub>1A</sub> receptors are involved in the anxiolytic effect of  $\Delta^9$ -tetrahydrocannabinol and AM 404, the anandamide transport inhibitor, in Sprague–Dawley rats. *Eur J Pharmacol* [Internet]. 2007 Jan;555(2–3):156–63. Available from: <https://linkinghub.elsevier.com/retrieve/pii/S0014299906011502>
123. Kasten CR, Zhang Y, Boehm SL. Acute and long-term effects of  $\Delta^9$ -tetrahydrocannabinol on object recognition and anxiety-like activity are age- and strain-dependent in mice. *Pharmacol Biochem Behav* [Internet]. 2017 Dec;163:9–19. Available from: <https://linkinghub.elsevier.com/retrieve/pii/S0091305716302672>
124. Zagzoog A, Mohamed KA, Kim HJJ, Kim ED, Frank CS, Black T, et al. In vitro and in vivo pharmacological activity of minor cannabinoids isolated from *Cannabis sativa*. *Sci Rep* [Internet]. 2020 Dec 23;10(1):20405. Available from: <http://www.nature.com/articles/s41598-020-77175-y>
125. Hart C, Ward A, Haney M, Comer S, Foltin R, Fischman M. Comparison of smoked marijuana and oral  $\Delta^9$ -tetrahydrocannabinol in humans. *Psychopharmacology (Berl)* [Internet]. 2002 Dec 1;164(4):407–15. Available from: <http://link.springer.com/10.1007/s00213-002-1231-y>
126. Haney M, Gunderson EW, Rabkin J, Hart CL, Vosburg SK, Comer SD, et al. Dronabinol and Marijuana in HIV-Positive Marijuana Smokers. *JAIDS J Acquir Immune Defic Syndr* [Internet]. 2007 Aug 15;45(5):545–54. Available from: <https://journals.lww.com/00126334-200708150-00009>
127. Farrimond JA, Whalley BJ, Williams CM. Cannabinol and cannabidiol exert opposing effects on rat feeding patterns. *Psychopharmacology (Berl)* [Internet]. 2012 Sep 28;223(1):117–29. Available from: <http://link.springer.com/10.1007/s00213-012-2697-x>
128. Kang M, Lee J, Park S. Cannabidiol induces osteoblast differentiation via angiotensin II and p38 MAPK. *Environ Toxicol* [Internet]. 2020 Dec 13;35(12):1318–25. Available from: <https://onlinelibrary.wiley.com/doi/10.1002/tox.22996>
129. Raphael-Mizrahi B, Gabet Y. The Cannabinoids Effect on Bone Formation and Bone Healing. *Curr Osteoporos Rep* [Internet]. 2020 Oct 23;18(5):433–8. Available from: <http://link.springer.com/10.1007/s11914-020-00607-1>
130. Fellous T, De Maio F, Kalkan H, Carannante B, Boccella S, Petrosino S, et al. Phytocannabinoids promote viability and functional adipogenesis of bone marrow-derived mesenchymal stem cells through different molecular targets. *Biochem Pharmacol* [Internet]. 2020 May;175:113859. Available from: <https://linkinghub.elsevier.com/retrieve/pii/S0006295220300873>
131. Scutt A, Williamson EM. Cannabinoids stimulate fibroblastic colony formation by bone marrow cells indirectly via CB<sub>2</sub> receptors. *Calcif Tissue Int*. 2007;80(1):50–9.
132. Nichols JM, Kaplan BLF. Immune Responses Regulated by Cannabidiol. *Cannabis Cannabinoid Res* [Internet]. 2020 Mar 1;5(1):12–31. Available from: <https://www.liebertpub.com/doi/10.1089/can.2018.0073>

133. Peyravian N, Deo S, Daunert S, Jimenez JJ. Cannabidiol as a Novel Therapeutic for Immune Modulation. *ImmunoTargets Ther* [Internet]. 2020 Aug;Volume 9:131–40. Available from: <https://www.dovepress.com/cannabidiol-as-a-novel-therapeutic-for-immune-modulation-peer-reviewed-article-ITT>
134. EISENSTEIN T, MEISSLER J, WILSON Q, GAUGHAN J, ADLER M. Anandamide and  $\Delta^9$ -tetrahydrocannabinol directly inhibit cells of the immune system via CB2 receptors. *J Neuroimmunol* [Internet]. 2007 Sep;189(1–2):17–22. Available from: <https://linkinghub.elsevier.com/retrieve/pii/S0165572807001853>
135. Yang X, Bam M, Nagarkatti PS, Nagarkatti M. RNA-seq Analysis of  $\delta^9$ -Tetrahydrocannabinol-treated T Cells Reveals Altered Gene Expression Profiles That Regulate Immune Response and Cell Proliferation. *J Biol Chem* [Internet]. 2016 Jul;291(30):15460–72. Available from: <https://linkinghub.elsevier.com/retrieve/pii/S002192582039685X>
136. Herring AC, Koh WS, Kaminski NE. Inhibition of the Cyclic AMP Signaling Cascade and Nuclear Factor Binding to CRE and  $\kappa$ B Elements by Cannabinol, a Minimally CNS-Active Cannabinoid. *Biochem Pharmacol* [Internet]. 1998 Apr;55(7):1013–23. Available from: <https://linkinghub.elsevier.com/retrieve/pii/S0006295297006308>
137. Cabral GA, Rogers TJ, Lichtman AH. Turning Over a New Leaf: Cannabinoid and Endocannabinoid Modulation of Immune Function. *J Neuroimmune Pharmacol* [Internet]. 2015 Jun 9;10(2):193–203. Available from: <http://link.springer.com/10.1007/s11481-015-9615-z>
138. Santos NAG, Martins NM, Sisti FM, Fernandes LS, Ferreira RS, Queiroz RHC, et al. The neuroprotection of cannabidiol against MPP<sup>+</sup>-induced toxicity in PC12 cells involves trkA receptors, upregulation of axonal and synaptic proteins, neuritogenesis, and might be relevant to Parkinson's disease. *Toxicol Vitro*. 2015;30(1):231–40.
139. Hampson AJ, Grimaldi M, Axelrod J, Wink D. Cannabidiol and (-) 9-tetrahydrocannabinol are neuroprotective antioxidants. *Proc Natl Acad Sci* [Internet]. 1998 Jul 7;95(14):8268–73. Available from: <http://www.pnas.org/cgi/doi/10.1073/pnas.95.14.8268>
140. di Giacomo V, Chiavaroli A, Orlando G, Cataldi A, Rapino M, Di Valerio V, et al. Neuroprotective and Neuromodulatory Effects Induced by Cannabidiol and Cannabigerol in Rat Hypo-E22 cells and Isolated Hypothalamus. *Antioxidants* [Internet]. 2020 Jan 13;9(1):71. Available from: <https://www.mdpi.com/2076-3921/9/1/71>
141. Stone NL, Murphy AJ, England TJ, O'Sullivan SE. A systematic review of minor phytocannabinoids with promising neuroprotective potential. *Br J Pharmacol*. 2020;177(19):4330–52.
142. Valdeolivas S, Navarrete C, Cantarero I, Bellido ML, Muñoz E, Sagredo O. Neuroprotective Properties of Cannabigerol in Huntington's Disease: Studies in R6/2 Mice and 3-Nitropropionate-lesioned Mice. *Neurotherapeutics* [Internet]. 2015 Jan 25;12(1):185–99. Available from: <http://link.springer.com/10.1007/s13311-014-0304-z>
143. Espadas I, Keifman E, Palomo-Garo C, Burgaz S, García C, Fernández-Ruiz J, et al. Beneficial effects of the phytocannabinoid  $\Delta^9$ -THCV in L-DOPA-induced dyskinesia in Parkinson's disease. *Neurobiol Dis* [Internet]. 2020 Jul;141:104892. Available from: <https://linkinghub.elsevier.com/retrieve/pii/S0969996120301674>
144. Shinjyo N, Di Marzo V. The effect of cannabichromene on adult neural stem/progenitor cells. *Neurochem Int* [Internet]. 2013 Nov;63(5):432–7. Available from: <https://linkinghub.elsevier.com/retrieve/pii/S0197018613002106>
145. Aiken CT, Tobin AJ, Schweitzer ES. A cell-based screen for drugs to treat Huntington's disease. *Neurobiol Dis* [Internet]. 2004 Aug;16(3):546–55. Available from: <https://linkinghub.elsevier.com/retrieve/pii/S0969996104000828>
146. Shoyama Y, Yagi M, Nishioka I, Yamauchi T. Biosynthesis of cannabinoid acids. *Phytochemistry* [Internet]. 1975 Oct;14(10):2189–92. Available from: <https://linkinghub.elsevier.com/retrieve/pii/S0031942200910963>
147. Burke CC, Wildung MR, Croteau R. Geranyl diphosphate synthase: Cloning, expression, and characterization of this prenyltransferase as a heterodimer. *Proc Natl Acad Sci* [Internet]. 1999 Nov 9;96(23):13062–7. Available from: <http://www.pnas.org/cgi/doi/10.1073/pnas.96.23.13062>
148. Marks MD, Tian L, Wenger JP, Omburo SN, Soto-Fuentes W, He J, et al. Identification of candidate genes affecting  $\Delta^9$ -tetrahydrocannabinol biosynthesis in *Cannabis sativa*. *J Exp Bot* [Internet]. 2009 Sep;60(13):3715–26. Available from: <https://academic.oup.com/jxb/article-lookup/doi/10.1093/jxb/erp210>



149. Gagne SJ, Stout JM, Liu E, Boubakir Z, Clark SM, Page JE. Identification of olivetolic acid cyclase from *Cannabis sativa* reveals a unique catalytic route to plant polyketides. *Proc Natl Acad Sci U S A* [Internet]. 2012 Jul 31;109(31):12811–6. Available from: <http://www.pnas.org/cgi/doi/10.1073/pnas.1200330109>
150. Dubey VS, Bhalla R, Luthra R. An overview of the non-mevalonate pathway for terpenoid biosynthesis in plants. *J Biosci* [Internet]. 2003 Sep 1;28(5):637–46. Available from: <http://link.springer.com/10.1007/BF02703339>
151. Kempinski C, Jiang Z, Bell S, Chappell J. Metabolic Engineering of Higher Plants and Algae for Isoprenoid Production. In 2015. p. 161–99. Available from: [http://link.springer.com/10.1007/10\\_2014\\_290](http://link.springer.com/10.1007/10_2014_290)
152. Moses T, Pollier J, Thevelein JM, Goossens A. Bioengineering of plant (tri)terpenoids: from metabolic engineering of plants to synthetic biology in vivo and in vitro. *New Phytol* [Internet]. 2013 Oct 14;200(1):27–43. Available from: <https://onlinelibrary.wiley.com/doi/10.1111/nph.12325>
153. Gülck T, Møller BL. Phytocannabinoids: Origins and Biosynthesis. *Trends Plant Sci* [Internet]. 2020 Oct;25(10):985–1004. Available from: <https://linkinghub.elsevier.com/retrieve/pii/S1360138520301874>
154. Fellermeier M, Zenk MH. Prenylation of olivetolate by a hemp transferase yields cannabigerolic acid, the precursor of tetrahydrocannabinol. *FEBS Lett* [Internet]. 1998 May 8;427(2):283–5. Available from: <http://doi.wiley.com/10.1016/S0014-5793%2898%2900450-5>
155. Thomas F, Schmidt C, Kayser O. Bioengineering studies and pathway modeling of the heterologous biosynthesis of tetrahydrocannabinolic acid in yeast. *Appl Microbiol Biotechnol* [Internet]. 2020 Nov 12;104(22):9551–63. Available from: <http://link.springer.com/10.1007/s00253-020-10798-3>
156. Thomas BF, ElSohly MA. Biosynthesis and Pharmacology of Phytocannabinoids and Related Chemical Constituents. In: *The Analytical Chemistry of Cannabis* [Internet]. Elsevier; 2016. p. 27–41. Available from: <https://linkinghub.elsevier.com/retrieve/pii/B9780128046463000023>
157. de Meijer EPM, Hammond KM, Micheler M. The inheritance of chemical phenotype in *Cannabis sativa* L. (III): variation in cannabichromene proportion. *Euphytica* [Internet]. 2009 Jan 23;165(2):293–311. Available from: <http://link.springer.com/10.1007/s10681-008-9787-1>
158. Shoyama Y, Hirano H, Nishioka I. Biosynthesis of propyl cannabinoid acid and its biosynthetic relationship with pentyl and methyl cannabinoid acids. *Phytochemistry* [Internet]. 1984 Aug;23(9):1909–12. Available from: <https://linkinghub.elsevier.com/retrieve/pii/S0031942200849390>
159. de Meijer EPM, Hammond KM, Sutton A. The inheritance of chemical phenotype in *Cannabis sativa* L. (IV): cannabinoid-free plants. *Euphytica* [Internet]. 2009 Jul 31;168(1):95–112. Available from: <https://link.springer.com/10.1007/s10681-009-9894-7>
160. Nielsen J, Keasling JD. Synergies between synthetic biology and metabolic engineering. *Nat Biotechnol* [Internet]. 2011 Aug 1;29(8):693–5. Available from: <http://www.nature.com/articles/nbt.1937>
161. Carvalho Â, Hansen EH, Kayser O, Carlsen S, Stehle F. Designing microorganisms for heterologous biosynthesis of cannabinoids. *FEMS Yeast Res*. 2017;17(4):1–11.
162. Cheon Y, Kim J-S, Park J-B, Heo P, Lim JH, Jung GY, et al. A biosynthetic pathway for hexanoic acid production in *Kluyveromyces marxianus*. *J Biotechnol* [Internet]. 2014 Jul;182–183:30–6. Available from: <https://linkinghub.elsevier.com/retrieve/pii/S0168165614001849>
163. Coral J, Karp SG, Porto de Souza Vandenberghe L, Parada JL, Pandey A, Socol CR. Batch Fermentation Model of Propionic Acid Production by *Propionibacterium acidipropionici* in Different Carbon Sources. *Appl Biochem Biotechnol* [Internet]. 2008 Dec 2;151(2–3):333–41. Available from: <http://link.springer.com/10.1007/s12010-008-8196-1>
164. Taura F, Dono E, Sirikantaramas S, Yoshimura K, Shoyama Y, Morimoto S. Production of  $\Delta^1$ -tetrahydrocannabinolic acid by the biosynthetic enzyme secreted from transgenic *Pichia pastoris*. *Biochem Biophys Res Commun* [Internet]. 2007 Sep;361(3):675–80. Available from: <https://linkinghub.elsevier.com/retrieve/pii/S0006291X07015665>
165. Sutherlin A, Hedl M, Sanchez-Neri B, Burgner JW, Stauffacher C V., Rodwell VW. Enterococcus faecalis 3-Hydroxy-3-Methylglutaryl Coenzyme A Synthase, an Enzyme of Isopentenyl Diphosphate Biosynthesis. *J Bacteriol* [Internet]. 2002 Aug;184(15):4065–70. Available from: <https://journals.asm.org/doi/10.1128/JB.184.15.4065-4070.2002>

166. Reider Apel A, D'Espaux L, Wehrs M, Sachs D, Li RA, Tong GJ, et al. A Cas9-based toolkit to program gene expression in *Saccharomyces cerevisiae*. *Nucleic Acids Res* [Internet]. 2017 Jan 9;45(1):496–508. Available from: <https://academic.oup.com/nar/article-lookup/doi/10.1093/nar/gkw1023>
167. Ignea C, Pontini M, Maffei ME, Makris AM, Kampranis SC. Engineering Monoterpene Production in Yeast Using a Synthetic Dominant Negative Geranyl Diphosphate Synthase. *ACS Synth Biol* [Internet]. 2014 May 16;3(5):298–306. Available from: <https://pubs.acs.org/doi/10.1021/sb400115e>
168. Kim E-J, Son HF, Kim S, Ahn J-W, Kim K-J. Crystal structure and biochemical characterization of beta-keto thiolase B from polyhydroxyalkanoate-producing bacterium *Ralstonia eutropha* H16. *Biochem Biophys Res Commun* [Internet]. 2014 Feb;444(3):365–9. Available from: <https://linkinghub.elsevier.com/retrieve/pii/S0006291X14000795>
169. Segawa M, Wen C, Orita I, Nakamura S, Fukui T. Two NADH-dependent (S)-3-hydroxyacyl-CoA dehydrogenases from polyhydroxyalkanoate-producing *Ralstonia eutropha*. *J Biosci Bioeng* [Internet]. 2019 Mar;127(3):294–300. Available from: <https://linkinghub.elsevier.com/retrieve/pii/S138917231830505X>
170. Kim E-J, Kim Y-J, Kim K-J. Structural insights into substrate specificity of crotonase from the n-butanol producing bacterium *Clostridium acetobutylicum*. *Biochem Biophys Res Commun* [Internet]. 2014 Aug;451(3):431–5. Available from: <https://linkinghub.elsevier.com/retrieve/pii/S0006291X14014041>
171. Bond-Watts BB, Weeks AM, Chang MCY. Biochemical and Structural Characterization of the trans -Enoyl-CoA Reductase from *Treponema denticola*. *Biochemistry* [Internet]. 2012 Aug 28;51(34):6827–37. Available from: <https://pubs.acs.org/doi/10.1021/bi300879n>
172. Stout JM, Boubakir Z, Ambrose SJ, Purves RW, Page JE. The hexanoyl-CoA precursor for cannabinoid biosynthesis is formed by an acyl-activating enzyme in *Cannabis sativa* trichomes. *Plant J* [Internet]. 2012 Jun;no-no. Available from: <http://doi.wiley.com/10.1111/j.1365-313X.2012.04949.x>
173. Taura F, Tanaka S, Taguchi C, Fukamizu T, Tanaka H, Shoyama Y, et al. Characterization of olivetol synthase, a polyketide synthase putatively involved in cannabinoid biosynthetic pathway. *FEBS Lett* [Internet]. 2009 Jun 18;583(12):2061–6. Available from: <http://doi.wiley.com/10.1016/j.febslet.2009.05.024>
174. Sirikantaramas S, Morimoto S, Shoyama Y, Ishikawa Y, Wada Y, Shoyama Y, et al. The Gene Controlling Marijuana Psychoactivity. *J Biol Chem* [Internet]. 2004 Sep;279(38):39767–74. Available from: <https://linkinghub.elsevier.com/retrieve/pii/S0021925820727821>
175. Taura F, Sirikantaramas S, Shoyama Y, Yoshikai K, Shoyama Y, Morimoto S. Cannabidiolic-acid synthase, the chemotype-determining enzyme in the fiber-type *Cannabis sativa*. *FEBS Lett* [Internet]. 2007 Jun 26;581(16):2929–34. Available from: <http://doi.wiley.com/10.1016/j.febslet.2007.05.043>
176. Morimoto S, Komatsu K, Taura F, Shoyama Y. Purification and characterization of cannabichromenic acid synthase from *Cannabis sativa*. *Phytochemistry* [Internet]. 1998 Nov;49(6):1525–9. Available from: <https://linkinghub.elsevier.com/retrieve/pii/S0031942298002787>
177. Page JE, Stout JM. Cannabichromenic acid synthase from *cannabis sativa* [Internet]. WO2015196275A1, 2015. Available from: <https://patents.google.com/patent/WO2015196275A1>
178. Harrison RG, Todd PW, Rudge SR, Petrides DP. *Bioseparations Science and Engineering*. 2nd ed. Oxford University Press; 2015.
179. The MathWorks. *SimBiology Toolbox*. 2017.
180. De Deken RH. The Crabtree Effect: A Regulatory System in Yeast. *J Gen Microbiol* [Internet]. 1966 Aug 1;44(2):149–56. Available from: <https://www.microbiologyresearch.org/content/journal/micro/10.1099/00221287-44-2-149>
181. Valliere MA, Korman TP, Woodall NB, Khitrov GA, Taylor RE, Baker D, et al. A cell-free platform for the prenylation of natural products and application to cannabinoid production. *Nat Commun* [Internet]. 2019 Dec 4;10(1):565. Available from: <http://www.nature.com/articles/s41467-019-08448-y>
182. Zirpel B. *Recombinant Expression and Functional Characterization of Cannabinoid Producing Enzymes in Komagataella phaffii*. Technical University of Dortmund; 2018.

183. Schwarzhans JP, Luttermann T, Geier M, Kalinowski J, Friehs K. Towards systems metabolic engineering in *Pichia pastoris*. *Biotechnology Advances* Elsevier; 2017 p. 681–710.
184. Kideckel DM, Pallotta M, Hoang K. Synthetically-derived cannabinoids: The next generation of cannabinoid production [Internet]. 2019. Available from: [https://www.newcannabisventures.com/wp-content/uploads/2019/02/Synthetically-Derived\\_Cannabinoids\\_\\_The\\_Next\\_Generation\\_of\\_Cannabinoid\\_Production\\_February\\_20\\_2019.pdf](https://www.newcannabisventures.com/wp-content/uploads/2019/02/Synthetically-Derived_Cannabinoids__The_Next_Generation_of_Cannabinoid_Production_February_20_2019.pdf)
185. Government of Canada. Cannabis. 2021.
186. Presidente IL, Repubblica D. LEGGE 2 dicembre 2016, n. 242. *Gazz Uff.* 2016;304:1–6.
187. FDA. Regulation of Cannabis and Cannabis-Derived Product U.S Food & Drug Administration, Including Cannabidiol (CBD) [Internet]. 2021. Available from: <https://www.fda.gov/news-events/public-health-focus/fda-regulation-cannabis-and-cannabis-derived-products-including-cannabidiol-cbd>
188. Zaami S, Di Luca A, Di Luca NM, Vergallo GM, Montanari Vergallo G. Medical use of cannabis: Italian and European legislation. *Eur Rev Med Pharmacol Sci.* 2018;22(4):1161–7.
189. 1. Office of the Commissioner. FDA Regulation of Cannabis and Cannabis-Derived Products: Q&A. . US Food Drug Adm. 2021;
190. Food and Drug Administration. FDA approves first drug comprised of an active ingredient derived from marijuana to treat rare, severe forms of epilepsy. *Case Med Res* [Internet]. 2018 Jun 25; Available from: <https://my.casemedicalresearch.com/api/v2/doi/10.31525/fda2-ucm611046.htm>
191. Magalhães AI, de Carvalho JC, Medina JDC, Soccol CR. Downstream process development in biotechnological itaconic acid manufacturing. *Appl Microbiol Biotechnol* [Internet]. 2017 Jan 15;101(1):1–12. Available from: <http://link.springer.com/10.1007/s00253-016-7972-z>
192. Poulos JL, Farnia AN. Production of tetrahydrocannabinolic acid in yeast [Internet]. USA; US10392635B2, 2015. Available from: <https://patents.google.com/patent/US10392635B2/en>
193. Towle TR. Raising the Bar for Cannabis Extraction Methods: Introducing a Novel, Safe, Efficient, and Environmentally Friendly Approach to Extracting High Quality Cannabis Resins [Internet]. 2019. Available from: <https://cdn.technologynetworks.com/ac/resources/pdf/fall-2019-symposia-proceedings-of-the-cannabis-chemistry-subdivision-312347.pdf>
194. Turner CE, Elsohly MA. Constituents of cannabis sativa L. XVI. A possible decomposition pathway of  $\Delta^9$ -tetrahydrocannabinol to cannabinol. *J Heterocycl Chem* [Internet]. 1979 Dec;16(8):1667–8. Available from: <http://doi.wiley.com/10.1002/jhet.5570160834>
195. Repka MA, Munjal M, Elsohly MA, Ross SA. Temperature Stability and Bioadhesive Properties of  $\Delta^9$ -Tetrahydrocannabinol Incorporated Hydroxypropylcellulose Polymer Matrix Systems. *Drug Dev Ind Pharm* [Internet]. 2006 Jan 25;32(1):21–32. Available from: <http://www.tandfonline.com/doi/full/10.1080/03639040500387914>
196. Chambers A. Decarboxylation's Importance in the Cannabis Extraction Process. 2020.
197. Anderson D. Progress in Cannabinoid Purification and Testing [Internet]. 2017. Available from: <https://www.labx.com/resources/progress-in-cannabinoid-purification-and-testing/80>
198. RotaChrom. Adaptability and scale up [Internet]. 2019. Available from: <https://rotachrom.com/products/adaptability-and-scale-up/>
199. Chang A, Jeske L, Ulbrich S, Hofmann J, Koblitz J, Schomburg I, et al. BRENDA, the ELIXIR core data resource in 2021: New developments and updates. *Nucleic Acids Res* [Internet]. 2021 Jan 8;49(D1):D498–508. Available from: <https://academic.oup.com/nar/article/49/D1/D498/5992283>
200. Wittig U, Kania R, Golebiewski M, Rey M, Shi L, Jong L, et al. SABIO-RK - Database for biochemical reaction kinetics. *Nucleic Acids Res* [Internet]. 2012 Jan 1;40(D1):D790–6. Available from: <https://academic.oup.com/nar/article-lookup/doi/10.1093/nar/gkr1046>