

UNIVERSIDADE FEDERAL DO PARANÁ

MIRIAM RAFAELA BENINCA

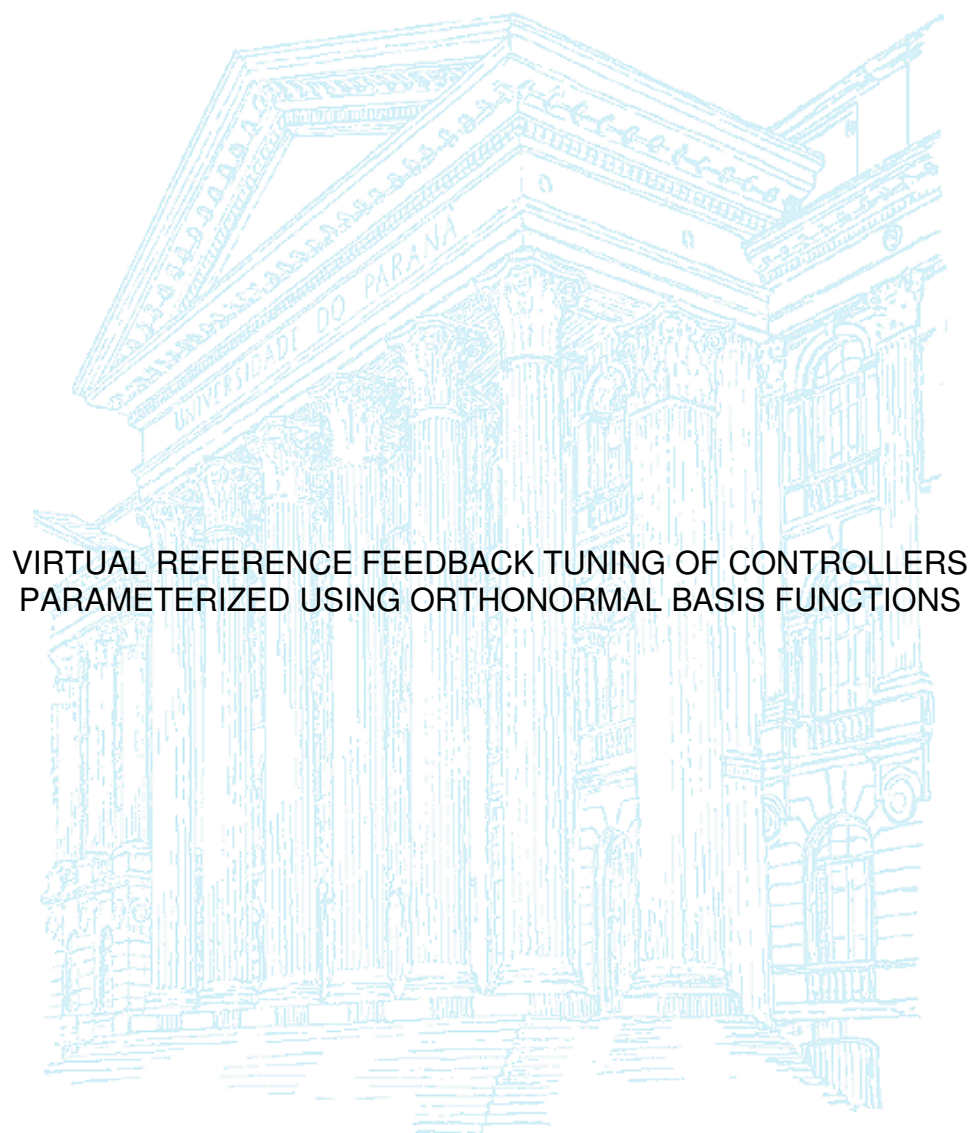

**VIRTUAL REFERENCE FEEDBACK TUNING OF CONTROLLERS
PARAMETERIZED USING ORTHONORMAL BASIS FUNCTIONS**

**CURITIBA
2015**

MÍRIAM RAFAELA BENINCA

VIRTUAL REFERENCE FEEDBACK TUNING OF CONTROLLERS
PARAMETERIZED USING ORTHONORMAL BASIS FUNCTIONS

Master's Thesis presented in partial fulfillment of the requirements for the degree of Master in Electrical Engineering Program from the Federal University of Paraná.

Supervisor: Dr. Gustavo Henrique da Costa Oliveira
Co-supervisor: Dr. Prof. Gideon Villar Leandro

CURITIBA
2015



UNIVERSIDADE FEDERAL DO PARANÁ
Programa de Pós-Graduação em Engenharia Elétrica
PPGEE
Setor de Tecnologia

ATA DE DEFESA DE MESTRADO

Aos oito dias do mês de julho de 2015, na sala PK 07 do Departamento de Engenharia Elétrica, foi instalada pelo Prof. Dr. Gustavo Henrique da Costa Oliveira, Coordenador do Programa de Pós-Graduação em Engenharia Elétrica, a Banca Examinadora para a centésima septuagésima quarta Dissertação de Mestrado do PPGEE, na Área de Concentração em **SISTEMAS ELETRÔNICOS**. Estiveram presentes no ato, além da Coordenadora do Curso de Pós-Graduação, professores, alunos e visitantes.

A Banca Examinadora, atendendo determinação do Colegiado do Programa de Pós-Graduação em Engenharia Elétrica, ficou constituída pelos professores doutores **Gustavo Henrique da Costa Oliveira (Orientador - UFPR); Lúcia Valéria Ramos de Arruda (UTFPR); Gideon Villar Leandro (Coorientador - UFPR); Alexandre Rasi Aoki (UFPR) e Marcelo Kaminski Lenzi (PPGEQ/UFPR)**.

Às 14:00 horas, a banca iniciou os trabalhos, convidando a candidata **MIRIAM RAFAELA BENINCA** a fazer a apresentação da dissertação intitulada **"VIRTUAL REFERENCE FEEDBACK TUNNIG OF CONTROLLERS PARAMETERIZED USING ORTHONORNAL BASIS FUNCTIONS"**. Encerrada a apresentação, iniciou-se a fase de argüição pelos membros participantes.

Tendo em vista a dissertação e a argüição, a banca decidiu pela:

APROVAÇÃO

NÃO APROVAÇÃO do candidato, (de acordo com a determinação da Resolução 63/03-CEPE).

Curitiba, 08 de junho de 2015.

Prof. Dr. **Gustavo Henrique da Costa Oliveira**

Profª. Drª. **Lúcia Valéria Ramos de Arruda**

Prof. Dr. **Gideon Villar Leandro**

Prof. Dr. **Alexandre Rasi Aoki**

Prof. Dr. **Marcelo Kaminski Lenzi**



TERMO DE APROVAÇÃO

MÍRIAM RAFAELA BENINCA

VIRTUAL REFERENCE FEEDBACK TUNING OF CONTROLLERS PARAMETERIZED USING ORTHONORMAL BASIS FUNCTIONS

Dissertação aprovada como requisito parcial para obtenção do grau de Mestre no Programa de Pós-Graduação em Engenharia Elétrica da Universidade Federal do Paraná, pela seguinte banca examinadora:



Prof. Dr. Gustavo Henrique da Costa Oliveira
Orientador – Departamento de Engenharia Elétrica, UFPR



Prof. Dr. Gideon Villar Leandro
Co-Orientador – Departamento de Engenharia Elétrica, UFPR

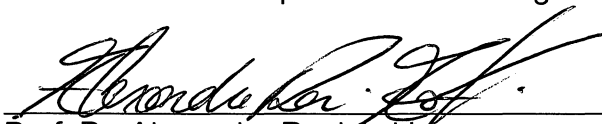

Prof. Dr. Alexandre Rasi Aoki
Departamento de Engenharia Elétrica, UFPR

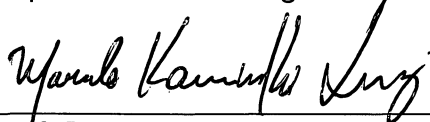

Prof. Dr. Marcelo Kaminski Lenzi
Departamento de Engenharia Química, UFPR



Prof^a. Dr^a. Lucia Valeria Ramos de Arruda
Pós-Graduação em Eng. Elétrica e Informática Industrial, UTFPR

Curitiba, 08 de Julho de 2015

ACKNOWLEDGMENTS

I would like to express my appreciation and thanks to my supervisor Dr. Gustavo Henrique da Costa Oliveira, whose expertise, encouragement and assistance added considerably to my graduate experience. I am also thankful to Dr. Gideon Villar Leandro for guidance through this research and graduate experience.

I give special thanks to my husband. Words cannot express how grateful I am to him for all his love, patience, kindness, support, and respect.

Finally, I would like to express my heartfelt gratitude to my parents for their everlasting love, understanding and encouragement.

“If we want to reduce poverty and misery, if we want to give to every deserving individual what is needed for a safe existence of an intelligent being, we want to provide more machinery, more power.
Power is our mainstay, the primary source of our many-sided energies.”

Nikola Tesla

ABSTRACT

To design and determine with accuracy controllers for dynamical systems has always been a challenge for engineering. In order to extend the application of controlled plants in real system many techniques have been developed, most of them with the objective of generalizing methods and permit controller design in an easier and assertive way. Therefore, since the first studies about the theory and practice on designing of PID controllers, a new control area based on data aims to get a controller whose system behaves as close as possible to a pre-defined reference. To this end, a single set of input and output data is collected from the plant in order to finally identify the dynamics of such closed-loop system. Data-based control techniques have two main strands. The first, an iterative technique known as Iterative Feedback Tuning (IFT) and the second one, a non-iterative model called Virtual Reference Feedback Tuning (VRFT) which aims to relate a virtual reference to a feedback system whose controller would be determined. The VRFT technique has the main advantage and characteristic of turning the task of the controller determination into a problem of system identification with a set of input and output data plus a virtual reference. To this end, it is common to find in literature studies that assume a fixed and pre-determined controller structures on VRFT, mainly related with the PID control structure. Still, the solution may fail to present a good performance because not always the chosen structure contains the ideal one whose identification brings the error with regards to the desired performance close to zero. Beyond several model structures used by systems identification methods, the orthonormal basis functions (OBF) models have been receiving much attention in the literature since the past decade. In the VRFT context, it has the great advantage of being able to generalize the controller structure and improve accuracy and applicability of the method. This is the main contribution of this work, which applies and analyses OBF-models to design controllers using the VRFT technique. The VRFT approach is better explained and its methodology, advantages and limitations are compared between similar procedures. In addition, it presents a potential alternative to enhance the VRFT technique and its results by using a generalized class of modeling structures described using orthonormal basis functions. The theory is applied on linear and nonlinear dynamical systems including a CSTR reactor in presence (or not) of noise measurements. After all, the presented modeling technique delivered notable results on both identification and closed loop evaluations. Consequently, the problem of determining a feasible VRFT controller for expected closed-loop system behavior is solved, making wider the applicability of solving complex problems of real dynamical systems by the VRFT technique.

Key-words: Orthonormal Basis Functions. Closed-loop Identification. Virtual Reference Feedback Tuning. Data-Base Controller Tuning.

RESUMO

Projetar e determinar com exatidão controladores para sistemas dinâmicos sempre foi um desafio para a engenharia e no intuito de ampliar a aplicação de plantas controladas em sistemas reais, muitas técnicas foram desenvolvidas para generalizar o método de projetar controladores e tornar essa tarefa mais fácil e assertiva. Dessa maneira, desde os primeiros estudos a respeito da teoria e prática de projeto de controladores PID, muitas outras ferramentas surgiram, dentre elas a área de controle baseado em dados, que tem por objetivo conseguir um controlador cujo sistema se comporte próximo a uma referência. Para tanto, utiliza-se um único dado de experimento com entradas e saídas coletados da planta a fim de determinar a dinâmica do sistema em malha fechada. A técnica de controle baseada em dados possui duas principais vertentes. A primeira é um processo iterativo bem representado pela técnica do Iterative Feedback Tuning (IFT). A segunda, conhecida como VRFT, ou *Virtual Reference Feedback Tuning*, é uma técnica não iterativa que tem por objetivo relacionar uma referência virtual a um sistema realimentado cujo controlador deseja-se determinar. Tal técnica tem a principal vantagem e característica de transformar o problema de determinação do controlador em um problema de identificação de sistemas com dados de entrada e saída virtuais calculados utilizando dados de uma planta de referência. Para tanto, é comum encontrar na literatura trabalhos que utilizam uma estrutura fixa e pré-determinada do controlador, normalmente estruturas PID. Porém, a aproximação de tal controlador apresenta falhas de identificação e de desempenho do sistema realimentado, pois nem sempre a estrutura escolhida contém a estrutura ideal, aquela cuja identificação aproxima o erro a zero ou muito próximo disso. Dentre diversos métodos de identificação de sistemas, as séries de base de função ortonormal (OBF) possuem a grande vantagem de poder generalizar tal estrutura de controlador e depender unicamente da quantidade de funções escolhidas para representar o sistema e de um polo ou um par de polos conjugado. Por fim, este trabalho apresenta a aplicação do método de base de funções ortonormais na identificação do controlador cujos dados são obtidos através da técnica de referência virtual (VRFT). A teoria foi aplicada em sistemas dinâmicos lineares e não lineares incluindo um reator químico do tipo CSTR em presença (ou não) de ruído de medição. A técnica foi testada em ambos os sistemas e sobre diversos níveis de ruído, apresentou resultados notáveis na etapa de identificação de sistemas e conseqüentemente produziu uma solução para o problema de determinar com precisão e facilidade o controlador para um sistema em malha fechada. A escolha da classe de controladores é então generalizada, o que permite ao sistema e à técnica do VRFT, grande aplicabilidade na solução de problemas complexos de sistemas dinâmicos reais.

Palavras-chave: Bases de Funções Ortonormais. Identificação em malha fechada. Referência Virtual. Controle Baseado em dados.

LIST OF FIGURES

FIGURE 1-1.	THESIS STRUCTURE BASED ON MANUSCRIPT.....	24
FIGURE 3-1.	UNITARY FEEDBACK CONTROL SYSTEM, BEING T THE DESIRED DYNAMICS.	40
FIGURE 3-2.	FILTERED u INPUT ON DIRECT METHOD.....	42
FIGURE 3-3.	INVERSE OF THE OBF CONTROLLER ON NON-DIRECT OBF- VRFT METHOD.	43
FIGURE 3-4.	FIRST CHART: INPUT OF THE CONTROLLER - e ; SECOND CHART: OUTPUT u' ; THIRD CHART: REAL INPUT FROM EXPERIMENTS u	45
FIGURE 3-5.	ESTIMATION RESULT USING CLASSICAL VRFT APPROACH WITH PRE-DEFINED CONTROL STRUCTURE, NO NOISE INPUT.	46
FIGURE 3-6.	ESTIMATION OF u AND u' USING OBF LAGUERRE CLASS OF CONTROLLER. SYSTEM WITHOUT NOISE INPUT; $N=6$	47
FIGURE 3-7.	ESTIMATION OF u' AND u USING OBF KAUTZ CLASS OF CONTROLLER. SYSTEM WITHOUT NOISE INPUT; $N=6$	48
FIGURE 3-8.	ERROR HISTOGRAM FROM ESTIMATION OF u USING OBF LAGUERRE AND KAUTZ CLASS OF CONTROLLER; $N=6$	49
FIGURE 3-9.	FIRST CHART: INPUT OF THE CONTROLLER - e ; SECOND CHART: OUTPUT u' ; THIRD CHART: REAL INPUT FROM EXPERIMENTS u	50
FIGURE 3-10.	ESTIMATION RESULT USING CLASSICAL VRFT APPROACH WITH PRE-DEFINED CONTROL STRUCTURE, NOISE WITH 0.1000 STANDARD DEVIATION.	51
FIGURE 3-11.	ESTIMATION OF u AND u' USING OBF LAGUERRE CLASS OF CONTROLLER, $N = 6$ FILTERS USED, NOISE WITH 0.1000 STANDARD DEVIATION.	52
FIGURE 3-12.	ESTIMATION OF u' USING OBF KAUTZ CLASS OF CONTROLLER, $N = 6$ FILTERS USED, NOISE WITH 0.1000 STANDARD DEVIATION.	52

FIGURE 3-13.	ESTIMATION OF u USING OBF KAUTZ CLASS OF CONTROLLER, $N = 6$ FILTERS USED, NOISE WITH 0.1000 STANDARD DEVIATION.....	52
FIGURE 3-14.	ERROR HISTOGRAM FROM ESTIMATION OF u USING OBF LAGUERRE AND KAUTZ CLASS OF CONTROLLER; $N=6$	53
FIGURE 3-15.	ESTIMATION OF u AND u' USING OBF LAGUERRE CLASS OF CONTROLLER, $N = 4$ FILTERS USED, NOISE WITH 0.1000 STANDARD DEVIATION.	54
FIGURE 3-16.	ESTIMATION OF u AND u' USING OBF KAUTZ CLASS OF CONTROLLER, $N = 4$ FILTERS USED, NOISE WITH 0.1000 STANDARD DEVIATION.	55
FIGURE 3-17.	ERROR HISTOGRAM FROM ESTIMATION OF u USING OBF LAGUERRE AND KAUTZ CLASS OF CONTROLLER; $N=4$	55
FIGURE 3-18.	STEP RESPONSE BY REFERENCE MODEL (DARK SOLID LINE). SYSTEM DESIGNED BY THE CLASSICAL METHOD (DASHED LINE), OBF LAGUERRE (DOTTED LINE) AND OBF KAUTZ (SOLID LINE).....	56
FIGURE 3-19.	TIME WEIGHTED ERROR FORM DESIRABLE AND DESIGNED RESPONSE OF: RESPONSE OF SYSTEM DESIGNED BY THE CLASSICAL METHOD (DASHED LINE), OBF LAGUERRE (DOTTED LINE) AND OBF KAUTZ (SOLID LINE).	57
FIGURE 3-20.	STEP RESPONSE BY REFERENCE MODEL, SYSTEM DESIGNED BY THE CLASSICAL METHOD, OBF LAGUERRE AND OBF KAUTZ, $N = 6$ FILTERS, NOISE WITH 0.1000 STANDARD DEVIATION.....	57
FIGURE 3-21.	TIME WEIGHTED FORM STEP RESPONSE BY REFERENCE MODEL. SYSTEM DESIGNED BY THE CLASSICAL METHOD, OBF LAGUERRE AND OBF KAUTZ, $N = 6$ FILTERS, NOISE WITH 0.1000 STANDARD DEVIATION.	58
FIGURE 3-22.	STEP RESPONSE BY REFERENCE MODEL. SYSTEM DESIGNED BY THE CLASSICAL METHOD, OBF LAGUERRE AND OBF KAUTZ, $N = 4$ FILTERS, NOISE WITH 0.1000 STANDARD DEVIATION.....	58

FIGURE 3-23.	TIME WEIGHTED FORM STEP RESPONSE BY REFERENCE MODEL. SYSTEM DESIGNED BY THE CLASSICAL METHOD, OBF LAGUERRE AND OBF KAUTZ, $N = 4$ FILTERS, NOISE WITH 0.1000 STANDARD DEVIATION.	59
FIGURE 3-24.	REAL AND ESTIMATED e DATA VIA OBF LAGUERRE AND KAUTZ.	62
FIGURE 3-25.	CLOSED-LOOP SYSTEM WITH CONTROLLER GIVEN BY CLASSICAL AND OBF VRFT METHODS AND THE REFERENCE OUTPUT.	63
FIGURE 3-26.	THE TIME WEIGHTED ERROR DEFINED BY CLASSICAL AND OBF CONTROLLER.	63
FIGURE 4-1.	UNITARY FEEDBACK CONTROL SYSTEM, BEING T THE DESIRED DYNAMICS.	67
FIGURE 4-2.	FILTERED u' CONTROLLER OUTPUT TO ASSURE OBF TRANSFER FUNCTION WITH ONE POLE EQUAL ONE.	69
FIGURE 4-3.	FIRST CHART: INPUT OF THE CONTROLLER - e ; SECOND CHART: OUTPUT u' ; THIRD CHART: REAL INPUT FROM EXPERIMENTS u	71
FIGURE 4-4.	ESTIMATION RESULT FROM u REAL AND ESTIMATED USING CLASSICAL VRFT APPROACH WITH PRE-DEFINED CONTROL STRUCTURE.	72
FIGURE 4-5.	ESTIMATION OF u' AND u USING VOLTERRA-LAGUERRE CLASS OF CONTROLLER, $n_1, n_2 = 4$ FILTERS USED.	73
FIGURE 4-6.	ESTIMATION OF u' AND u USING VOLTERRA-KAUTZ CLASS OF CONTROLLER, $n_1, n_2 = 4$ FILTERS USED.	73
FIGURE 4-7.	ERROR HISTOGRAM FROM ESTIMATION OF u USING OBF LAGUERRE AND KAUTZ CLASS OF CONTROLLER.	74
FIGURE 4-8.	CLOSED-LOOP RESULTS FOR CLASSICAL VRFT TECHNIQUE, VOLTERRA-LAGUERRE AND VOLTERRA-KAUTZ CONTROLLERS.	76
FIGURE 4-9.	A TIME WEIGHTED ABSOLUTE ERROR BETWEEN REFERENCE AND REAL CLOSED-LOOP OUTPUT y WHEN THE SYSTEM IS NOISE FREE.	76

FIGURE 4-10.	RESULT OF CLOSED-LOOP STEP FROM CLASSICAL IDENTIFICATION, VOLTERRA-LAGUERRE AND VOLTERRA-KAUTZ CONTROLLERS; NOISE WITH STANDARD DEVIATION 0.1000.	77
FIGURE 4-11.	TIME WEIGHTED ABSOLUTE ERROR BETWEEN REFERENCE AND REAL CLOSED-LOOP OUTPUT WHEN USING VOLTERRA-OBF CONTROLLERS; NOISE WITH STANDARD DEVIATION 0.1000	77
FIGURE 4-12.	CONTINUOUS STIRRED TANK REACTOR.....	79
FIGURE 4-13.	FIRST CHART: INPUT OF THE CONTROLLER - e ; SECOND CHART: OUTPUT u' ; THIRD CHART: REAL INPUT FROM EXPERIMENTS u	80
FIGURE 4-14.	IDENTIFICATION STEP FROM I/O DATA WHEN THE CONTROLLER CLASS DOES NOT BELONG TO THE CLASS OF THE IDEAL CONTROLLER (CLASSICAL IDENTIFICATION).....	81
FIGURE 4-15.	IDENTIFICATION STEP FROM I/O DATA GIVEN u REAL AND u' ESTIMATED.	82
FIGURE 4-16.	THE IDENTIFICATION STEP FROM I/O DATA WHEN THE CONTROLLER CLASS DOES NOT BELONG TO THE CLASS OF THE IDEAL CONTROLLER (CLASSICAL IDENTIFICATION) AND RESULT WHEN A VOLTERRA-KAUTZ CONTROLLER CLASS IS CHOSEN (OBF IDENTIFICATION).....	83
FIGURE 4-17.	ESTIMATION OF u AND u' USING OBF KAUTZ CLASS OF CONTROLLER.	84
FIGURE 4-18.	RESULT OF CLOSED-LOOP STEP FROM IO DATA WHEN THE CONTROLLER CLASS DOES NOT BELONG TO THE CLASS OF THE IDEAL CONTROLLER (CLASSICAL IDENTIFICATION) AND RESULT WHEN A VOLTERRA-OBF CONTROLLERS (OBF IDENTIFICATION).	85
FIGURE 4-19.	A TIME WEIGHTED ABSOLUTE ERROR BETWEEN REFERENCE AND REAL CLOSED-LOOP OUTPUT y WHEN USING LAGUERRE-VOLTERRA OBF CONTROLLER WHEN THE SYSTEM IS NOISE FREE.	85

LIST OF TABLES

TABLE 3-1.	COMPARATIVE RESULTS BETWEEN CLASSICAL VRFT, KAUTZ AND LAGUERRE FUNCTIONS AND QUANTITY OF FUNCTIONS..	59
TABLE 3-2.	COMPARATIVE RESULTS BETWEEN CLASSICAL VRFT, KAUTZ AND LAGUERRE FUNCTIONS AND QUANTITY OF FUNCTIONS..	60
TABLE 4-1.	RESULTS OF VOLTERRA-LAGUERRE AND VOLTERRA-KAUTZ METHODS FOR EACH VALUE OF NOISE DISTURBANCE.	75
TABLE 4-2.	RESULTS USING CLASSICAL VRFT TECHNIQUE AND QUANTITY OF NOISE DISTURBANCE v	75
TABLE 4-4.	SUMMARY OF RESULTS OF VOLTERRA-KAUTZ, VOLTERRA-LAGUERRE FUNCTIONS AND CLASSICAL VRFT $C(q, \theta)$ CONTROLLER.....	78
TABLE 4-5.	RESULTS OF VOLTERRA-LAGUERRE METHOD FOR EACH VALUE OF NOISE DISTURBANCE.....	84
TABLE 4-6.	RESULTS USING CLASSICAL VRFT TECHNIQUE AND QUANTITY OF NOISE DISTURBANCE v	84
TABLE 4-7.	SUMMARY OF RESULTS OF VOLTERRA-KAUTZ, VOLTERRA-LAGUERRE FUNCTIONS AND CLASSICAL VRFT $C(q, \theta)$ CONTROLLER.....	86

LIST OF ACRONYMS AND ABBREVIATIONS

ARMAX	Auto-regressive Moving Average with Exogenous Inputs
ARX	Auto-regressive with Exogenous Inputs
GOBF	Generalized Orthonormal Basis Functions
IFT	Iterative Feedback Tuning
ITAE	Integral Time-weighted Absolute Error
MSE	Mean Squared Error
OBF	Orthonormal Basis Functions
PID	Proportional-Integral-Derivative
VRFT	Virtual Reference Feedback Tuning
SISO	Single Input Single Output

LIST OF SYMBOLS

\mathfrak{R}	Real space
\mathbb{N}	Natural space
φ	Orthonormal filters
Φ	Z transform of Orthonormal filters
\mathcal{H}	Linear and nonlinear Volterra static mapping
ζ	Coefficients of second-order Volterra-OBF
\mathcal{C}^*	Class of structures
θ	Scalar parameters of controller
\mathcal{D}_c	Controller structures domain
$\delta(k)$	Unit impulse function
σ	Standard deviation
u	Input sequence
u'	Controlled variable on direct model
e	Error from reference and output
y	Output sequence
c_i	Linear and nonlinear OBF coefficients
G	Plant Transfer Function
C	Controller Transfer Function
T	Reference Transfer Function
l	Laguerre and Kautz states
v	Noise signal
c_{ij}	Second-order Volterra-OBF Coefficients
J	Objective Function
h_i	Scaled Volterra Kernel of order i
k	Discrete time index
r	Reference Signal
n	Orthonormal Basis Functions order
\hat{y}	Estimated output sequence
A	State Matrix from state-space representation
B	Input Matrix from state-space representation
C	Output Matrix from state-space representation

D Feedthrough Matrix from state-space representation
 x State Vector from state-space representation

TABLE OF CONTENTS

1	INTRODUCTION	18
1.1	INTRODUCTION	18
1.2	ORTHONORMAL BASIS FUNCTIONS AND SYSTEM IDENTIFICATION	22
1.3	OBJECTIVES	23
1.3.1	Specific Objectives	23
1.4	OVERVIEW	24
2	ORTHONORMAL BASIS FUNCTIONS IN THE SYSTEM IDENTIFICATION	
	CONTEXT	26
2.1	CONCEPTS ON SYSTEM IDENTIFICATION USING ORTHONORMAL BASIS FUNCTIONS	26
2.2	DEVELOPMENT OF OBF MODELS FOR LINEAR SYSTEMS.....	28
2.2.1	Laguerre Filters	31
2.2.2	Kautz Filters.....	31
2.3	DEVELOPMENT OF OBF MODELS FOR NONLINEAR SYSTEMS.....	32
2.3.1	OBF-Volterra Models	33
2.4	FINAL REMARKS.....	35
3	NEW CONTROL STRUCTURE WITH VIRTUAL REFERENCE USING	
	ORTHONORMAL BASIS FUNCTIONS ON LINEAR SYSTEMS	36
3.1	INTRODUCTION	36
3.2	THE VRFT TECHNIQUE	39
3.3	CONTROL STRUCTURE FOR VRFT USING ORTHONORMAL BASIS FUNCTIONS: A DIRECT APPROACH.....	42
3.4	CONTROL STRUCTURE FOR VRFT USING ORTHONORMAL BASIS FUNCTIONS: A NON-DIRECT APPROACH.....	43
3.5	SIMULATION EXAMPLES	44
3.5.1	A Direct Approach	45
3.5.2	A Non-Direct Approach.....	60
3.6	CONCLUSION.....	64

4	THE VIRTUAL REFERENCE FEEDBACK TUNING USING VOLTERRA-ORTHONORMAL BASIS FUNCTIONS FOR NONLINEAR SYSTEMS	65
4.1	INTRODUCTION	65
4.2	THE VIRTUAL REFERENCE FEEDBACK TUNING TECHNIQUE FOR NONLINEAR SYSTEMS.....	67
4.3	CONTROL STRUCTURE ON VRFT USING VOLTERRA-OBF	68
4.4	SIMULATION EXAMPLE.....	70
4.4.1	General Case Study	70
4.4.2	Continuous Stirred Tank Reactor (CSTR) Case Study	78
4.5	CONCLUSION.....	86
5	CONCLUSIONS AND FUTURE WORK.....	88
5.1	CONCLUSIONS	88
5.2	LIMITATIONS	89
5.3	FUTURE WORK.....	90

1 INTRODUCTION

This thesis is based on the context and challenges of controller tuning techniques based on virtual reference. It specially works with a non-iterative data-based tuning technique called Virtual Reference Feedback Tuning, also named VRFT. In the following sub-sections, this study intends to introduce the VRFT approach by better explaining its methodology, advantages and limitations between similar procedures. Finally, it presents a potential alternative to enhance the VRFT technique and its results by using a generalized class of modeling structures described using orthonormal basis functions.

1.1 Introduction

The development of mathematical models to understand, predict and control the environment has always been a challenge. To this end, the scientific community develops and uses several mathematical models to simulate real situations on a computer. These mathematical models can be obtained from the laws of physics, but the cost of this type of evaluation is very high since it involves time and difficulty of obtaining a correct model and therefore valid results.

Since the first publications and studies of (ZIEGLER; NICHOLS, 1942) about pioneering work on industrial PID controller design, there is an increasing need for methods to determine controllers for many practical applications. As the accuracy when computing the controller parameters usually affects the overall response of the designed system, its closed-loop performance is highly dependent on the choice of an appropriate controller model and on several tuning parameters. The controller synthesis is usually based on a model of the system under control. Due to the complexity of the processes being highly increasing, the traditional process of modeling using physical laws becomes unfeasible for many practical situations.

At the other end of possible modeling strategies for the feedback control, from the past twenty years several methods have been developed to identify the transfer function of systems based on information retrieved from experimental data. Usually less expensive and time-consuming than mathematical models designed using first principles of physical laws, such system identification approaches are commonly considered for process modeling for controller synthesis and/or indirect and direct adaptive control methods

(ASTROM; HAGGLUND, 1995). Being fundamentally dependent on experimental data, those techniques disadvantages rely on very successful system identification procedures which can, however, be translated in some cases into underestimation of noise from the experimental data, poorly designed models and biased model during the online closed-loop system operation, such as in the adaptive controller choice.

Similarly from data-driven methods and standard online adaptive control, a latest approach called data-based tuning technique is also based on a batch of data collected from the plant. Despite the parallels between these two approaches, the main advantage of data-based technique over online adaptive control is that the controller design is performed offline and the final controller can be tested regarding closed-loop behaviour before placed in the real system (CAMPI; SAVARESI, 2006).

Since the earliest work of (GUARDABASSI; SAVARESI, 1997), data-based techniques represent a new horizon of development that has emerged in the past decade. In addition to the advantages already mentioned, the present technique distinguishes itself from others by not requiring constant interventions on plant to collect experimental data and its wide applicability, since there is no need of prior knowledge of process behavior and its transfer function but only a set of input and output data obtained from field experiments, a control class structure and a cost function (CAMPI et al., 2002; NEUHAUS, 2012).

In recent literature, two mainly approaches of data-based tuning methods can be found, the IFT (Iterative Feedback Tuning) and the VRFT (Virtual Reference Feedback Tuning). Called as direct methods by means of direct convergence to the controller selection, they differ by having or not an iterative process, which means using many experiments from the plant in an iterative methodology to find an optimal result. Well represented by the IFT (Iterative Feedback Tuning), the iterative process first proposed by (HJALMARSSON et al., 1994) and based on an iterative gradient-descent approach, is considered to have high approximation accuracy due to re-tune of the controller at each iteration (CAMPI et al., 2002; CAMPESTRINI, 2010). In opposition, many experiments are needed to achieve a finest controller, which minimizes the benefits of low interventions on process for measurements when comparing to a non-iterative technique, for instance the VRFT (Virtual Reference Feedback Tuning) first described by (CAMPI et al., 2002).

Likewise, by obtaining only one I/O (input/output) data from the system, the performance criteria and evaluation steps are substantially different on the VRFT controller

tuning approach. In such technique, both pre-defined I/O data and a class of structures are used to identify the parameters of the controller, whose estimation process, through minimization of a quadratic cost function, has remarkable convergence to the global minimum. In addition, considering the conditions of the unknown plant, the VRFT accuracy is highly depend on the information content on the set of I/O data, especially under noisy measurements and a suboptimal choice of the controller class, which is not necessarily restricted to PID controllers (CAMPI et al., 2002; CAMPI; SAVARESI, 2006).

Given a condition that the ideal controller is the one whose closed-loop system behaves as a given reference transfer function, if the controlled and reference systems are fed by the same input signal, both outputs must be the identical. In order to achieve such condition, the traditional reference tuning technique tries to impose a suitable choice of a reference input and then a controller structure such that the fundamental condition is satisfied. However, when it comes about real situations, such wise selection of the reference signal is not an easy task and that is why (CAMPI et al., 2002) presented a step by step methodology to address the problem of finding a proper reference signal in VRFT technique given a class of controller. To do so, it creates a new variable called *tracking error*, obtained equating the real output from a set of I/O data and the response of the reference transfer function to the same signal. This idea reduces the controller-tuning task into an identification problem where, given a controller class, if the input is the tracking error, the output must be given by the initial input from the I/O data.

Besides the benefits of such new approach, a problem remains on the identification step of the VRFT procedure. Generally speaking, when working with prediction error methods for model identification (LJUNG, 1999; AGUIRRE, 2007), one of the challenging tasks is to determine the most appropriated model structure. In the context of VRFT procedure, such issue is equivalent to determine the most appropriated structure for the controller, which may not be a PID structure or its derivations. To minimize error on conditioning when the class of controller chosen does not contain the ideal one, the same paper (CAMPI et al., 2002) proposes a suitable pre-filter so that the identified controller is nearly optimal for cost reduction. The application of such pre-filter also requires a better knowledge of the plant and its dynamics, which compromises the benefits of the virtual reference and its applicability in real and unknown plants.

Following the methodology of the *tracking error* first presented by (CAMPI et al., 2002), many studies addressed different ways to minimize the effect of bad conditioning of

the controller class by avoiding the use of such pre-filter also presented by the author but sustaining the use of a PID control structure due to its simplicity and large applicability in real systems. One example of this approach is the paper presented by (YANG et al., 2012) which uses an adaptive VRFT technique by increasing the reference model order and upgrading its parameters at each sampling instant. More recently, (RODRIGUES et al., 2014) presented an algorithm to identify the best reference model structure (given some control performance criteria) in order to optimize a PID or PI controller response.

When it comes about nonlinear systems, (CAMPI; SAVARESI, 2006) generalized the VRFT technique for both linear and nonlinear systems and two years later, (KANSHA et al., 2008) applied an adaptive control structure to enhance PID parameters via VRFT design at each sampling instant. After that, (CUNHA; BAZANELLA, 2012; FORMENTIN et al., 2013) introduced an alternative to enhance VRFT controller parameterization by improving nonlinear compensation and the second one manipulates the input signal such that the control cost is reduced.

As from now, many papers addressed efforts to improve the VRFT performance on linear and nonlinear systems by manipulating input signals, compensating static nonlinearities or enhanced VRFT design by introducing an adaptive methodology (YANG et al., 2012). Therefore, understanding and controlling more and more complex system behaviours are the key objectives on development of new controller tuning techniques and system identification models. In this context, not only the development of the VRFT technique is important but the model structure used to identify the controller must be enriched. In such way, although very practical from the implementation point of view, PID structures can be a real limitation on the VRFT procedure and that system identification theory, numerous good mathematical models for representing dynamic systems were developed.

Beyond various model structures available in the literature, the Orthonormal Basis Functions (OBF), has been widely applied in system identification problems and can be a solution to widespread the application of the VRFT technique by using a single controller class structure.

1.2 Orthonormal Basis Functions and System Identification

Since the first publications of (WIENER, 1958) it has been an increasing interest in the application of orthonormal basis functions (OBF) for dynamic system modeling, mostly using Laguerre and Kautz constructions and its generalizations (GOBF) as proposed by (HEUBERGER et al., 1995; NINNESS; GUSTAFSSON, 1997). The main applications are in system identification and adaptive signal processing, where the parameterization of models in terms of finite expansion coefficients is attractive due the linear-in-parameters model structure (HEUBERGER et al., 2005).

When it comes about the OBF functions of Laguerre and Kautz and its generalizations, all share the advantages of not having output regression Equations, differently than ARX and ARMAX models and its nonlinear developments. In addition, there is no need on pre-defining past relevant terms of the system or especially dealing with time delays and unmodelled dynamics. The accuracy and capability of both models can be increased by simply improving number of functions and the representation of a stable system is always stable (CAMPELLO et al., 2007; OLIVEIRA et al., 2012).

Laguerre and Kautz functions are preferred when modeling system with first and second order dominant dynamics while Generalized Orthonormal Basis Functions (GOBF) constructions are normally applied when identifying more complex dominant dynamics. Given the same set of orthonormal functions presented by (NINNESS; GUSTAFSSON, 1997; HEUBERGER et al., 2005), the Laguerre basis is obtained by considering the pole as a real and unique value. On the other hand, on Kautz functions, another important realization of that unifying construction, the poles are equal conjugated pairs. Due their simplicity and large range of applicability, Laguerre and Kautz functions are the main scope of this study.

As in any system identification procedures using series of functions, the finite number of Equations causes an error of prediction and, in the case of OBF, optimizing the choice of the pole in Laguerre and Kautz basis is a good option to improve the accuracy of the method using a small quantity of terms. Many papers addressed efforts to improve the selection of Kautz and Laguerre poles, among them (ROSA et al., 2009; REGINATO, 2007), and references there in.

Furthermore, when it comes about nonlinear systems (NELLES, 2001), a solution using Volterra and Orthonormal Basis series can be used to identify models for nonlinear

plants. Widely used in such situations, the Volterra series expansions has the main feature the fact of being able to approximate with accuracy any fading memory nonlinear system. Additionally, the Volterra series are linear with respect to parameters called the *kernel* coefficients and it is known as a nonlinear extension of FIR model sharing the characteristic of having great stability but large number of parameters.

In this context, an approach to reduce the number of terms in Volterra series considers expanding Volterra kernels onto orthonormal basis functions, which can be developed using a single real-valued parameter or a pair of complex conjugated poles. Known as Laguerre-Volterra and Kautz-Volterra models these nonlinear series of functions will be detailed and described in the following Chapters of this work.

1.3 Objectives

After settling the main parameters and properties of both VRFT technique and OBF models, this study intends to develop and implement a methodology using orthonormal basis functions capable of generalizing the class of controllers on the VRFT technique.

1.3.1 Specific Objectives

In other words, the work done in this thesis attempts to enhance the controller parametrization given a technique called Virtual Reference Feedback Tuning (VRFT). The identification of the controller is performed using a series of Orthonormal Basis Functions (OBF), a well-known model capable of generalizing a class of control structures and increase the potentiality of the Virtual Tuning procedure. The specific conditions of this research are:

- To analyze and develop new results regarding the OBF-Controller synthesis for linear system by using VRFT technique;
- To analyze and develop new results regarding the Volterra-OBF-Controller synthesis for nonlinear system by using VRFT technique;
- To test procedures for selecting the OBF model dynamics.

1.4 Overview

This thesis is organized as represented by Figure 1-1. Chapters 3 and 4 are not strictly related or connected even though altogether they pursue the general and specific objectives proposed in Section 1.3 and 1.4. Readers can find specific information about VRFT-OBF application on linear and nonlinear systems, its developments and simulations in each corresponded Chapter.

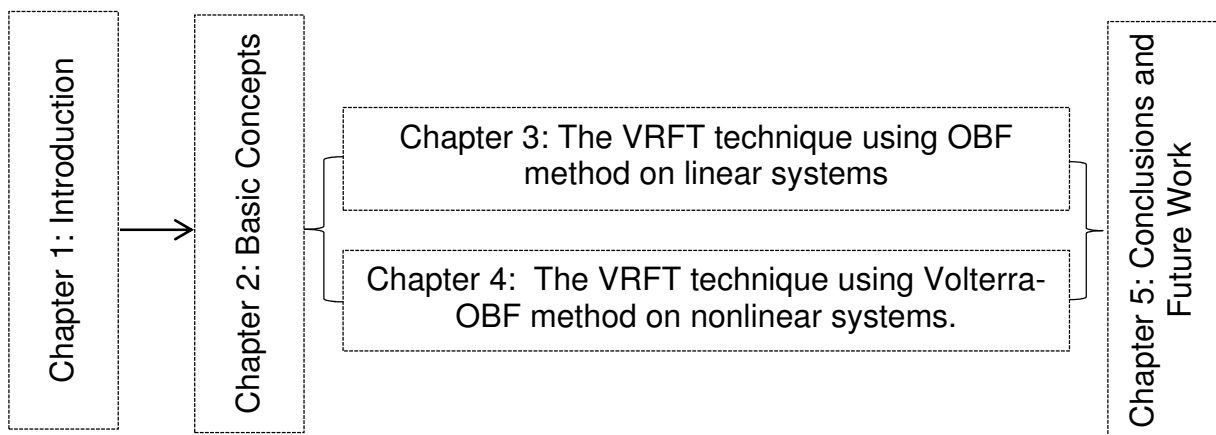

FIGURE 1-1. THESIS STRUCTURE BASED ON MANUSCRIPT.

Following Figure 1-1, this Chapter is an introduction into the problem as well some brief description of the concepts used. In the sequence, Chapter 2 reviews some background concepts related with OBF models while Chapters 3 and 4 intend to complement the application of Orthonormal Functions in the Virtual Tuning procedure for linear and nonlinear approaches, respectively. Lastly, the 5th Chapter concludes and provide proposals for future works.

Chapter 2 – Orthonormal Basis Functions in the System Identification Context:

This Chapter consists of a summary of the System Identification theory on Orthonormal Basis Functions context. It describes the functions and mathematical developments of Kautz and Laguerre orthonormal filters and details the application of such filters on linear and nonlinear systems.

Chapter 3 – New Control Structure with Virtual Reference Using Orthonormal Basis Functions on Linear Systems:

This Chapter introduces a paper that evaluates and describes the linear application of Laguerre and Kautz Orthonormal Basis

Functions in VRFT technique. In this Chapter the resulting model consists of a set of orthonormal filters that generalizes the class of control structures and provide great accuracy and outstanding approximation results to the reference model even when the plant dynamic is not known.

Chapter 4 – The Virtual Reference Feedback Tuning Using Volterra-Orthonormal Basis Functions for Nonlinear Systems: This Chapter introduces a paper that evaluates and describes the nonlinear application of Volterra-Laguerre and Volterra-Kautz in VRFT technique. Two systems are evaluated including a CSTR chemical reactor.

Chapter 5 – Conclusions and Future Work: Finally Chapter 5 is a brief conclusion of the results and suggestions for future works.

2 ORTHONORMAL BASIS FUNCTIONS IN THE SYSTEM IDENTIFICATION CONTEXT

As already discussed in Chapter 1, this study intends to generalize the class of control structures chosen a priori and used in the VRFT technique in the identification step. Among many ways to generalize such class of structures and provide better tuning of the controller in the VRFT technique, this work presents a solution using the series of orthonormal basis function. Therefore, this Section intends to explain the benefits of this approach as well give to the reader a better knowledge about the model and its properties.

2.1 Concepts on System Identification using Orthonormal Basis Functions

When it comes about control systems field, models are widely used to predict, simulate and design new process and evaluate performance of existing ones. Advanced techniques for tuning, optimization and supervision of controllers are usually based on estimated models for the plant or process. That is why the accuracy when estimating a model usually affects the overall response of the designed system and so its closed-loop performance is highly dependent on the choice of an appropriate prediction model and on several tuning parameters. Therefore, during the design stage, increasingly advanced innovative modeling and identification techniques becomes a need when solving new challenging problems.

The theory of linear and nonlinear system identification has been developed since the theoretical foundation for system identification done by (LJUNG, 1999; EYKHOFF, 2001; BILLINGS, 1980). In order to provide better approximation, many linear and nonlinear model structures are commonly used in control problems, when it comes about linear input-output model structures, most of them can be derived from one general structure given by Equation (2-1). The general linear structure consist of plant input u and a noise component e , filtered by a corresponding linear filter in which the system output y is represented in term of past input/output (I/O) values (LJUNG, 1987; SJÖBERG; LJUNG, 1995; TUFA et al., 2010).

$$y(k) = \frac{B(q)}{F(q)A(q)}u(k) + \frac{C(q)}{D(q)A(q)}e(k). \quad (2-1)$$

From (2-1), $A(q)$, $B(q)$, $C(q)$, $D(q)$ and $F(q)$ are polynomials in the shift operator q .

The selection of the appropriate model structure for a specific problem depends on the number of parameters required to describe a system with acceptable degree of accuracy and the computational cost when estimating parameters. Due to simplicity in estimating model parameters using least squares algorithm, the Auto-Regressive with Exogenous Inputs - ARX - and the Finite Impulse Response - FIR - models (LJUNG, 1987; HOOG, DE, 2001), described by Equation (2-2) and (2-3) respectively which are two special cases of model from Equation (2-1), are the most widely linear models used.

$$y(k) = \frac{B(q)}{A(q)}u(k) + \frac{1}{A(q)}e(k); \quad (2-2)$$

$$y(k) = B(q)u(k) + e(k). \quad (2-3)$$

Although several advantages, such as allowing parsimonious representations for unstable systems (NELLES, 2001; OLIVEIRA et al., 2011), the ARX model structure may leads to inconsistent parameters for most open-loop identification problems. In addition, the auto-regressive aspect generally increases the sensitivity regarding the choice of the model order and the common denominator A on ARX (and ARMAX - Auto Regressive Moving Average with Exogenous Input - see Equation 2-4), construction creates dependence between the input and noise ratio, which usually does not exist in reality. Both characteristics generate a recursion of errors that can damage the quality of the prediction, especially for long-range prediction horizons (TUFA et al., 2010; OLIVEIRA et al., 2011).

$$y(k) = \frac{B(q)}{A(q)}u(k) + \frac{C(q)}{A(q)}e(k); \quad (2-4)$$

In order to provide a potential alternative for the previously mentioned drawbacks, one approach that worth studying with particular interest consist of models without output feedback (NELLES, 2001). In this scenario, FIR models could be a suitable choice, however, when the true dynamic of the system have a slow mode, the model order using FIR needs very large number of parameters to capture the dynamic of a system with acceptable accuracy (NINNESS; GUSTAFSSON, 1997).

To overcome such difficulties, a choice is model structures linear-in-parameters such as the Orthonormal Basis Filter models which have several characteristics that make them very promising for control relevant system identification compared to most classical models (CAMPELLO et al., 2007; TUFA et al., 2010; OLIVEIRA et al., 2012):

- There is no auto-regressive effect and feedback errors, damaging the quality of long range prediction (OLIVEIRA et al., 2011);
- It is not necessary to know the I/O regressors of the system model, whose procedures of determination is not trivial, particularly on the nonlinear case;
- Functions parameters can be easily calculated using linear squares algorithm due linear in parameter construction, even on nonlinear modeling;
- Consistency in parameters for most practical open-loop identification problems;
- Effectiveness on both open and closed-loop identifications;
- Effectiveness on modeling systems with uncertain time delays;
- Natural decoupling of multiple outputs in multivariate models and a set of statistical properties favorable to numerical estimation of linear models in the parameters via least-squares algorithm;
- Every linear and nonlinear stable system described by OBF and NOBF is also stable.

In addition, recent results by (TUFA et al., 2010) prove that OBF based structures can present superior performance for closed-loop and multi-step ahead prediction compared to autoregressive models on linear and nonlinear system identification problems. Finally, without output feedback and known for significantly reduce the number of terms compared to FIR models, the Laguerre and Kautz basis functions (WAHLBERG, 1991, 1994; NINNESS et al., 1999) are the most commonly used basis functions in the approximation of signals and systems. In the following Sections, the developments of such functions are detailed for both linear and nonlinear systems.

2.2 Development of OBF models for linear systems

The knowledge behind the OBF representation in dynamic systems is the expansion of the impulse response in term of orthonormal filters (CAMPELLO et al., 2007). So, from the classical model of impulse response, consider a SISO (single input, single output), causal system with finite memory, described by its transfer function H (HEUBERGER et al., 2005; AGUIRRE, 2007):

$$y(k) = H(q)u(k). \quad (2-5)$$

or its convolution sum:

$$y(k) = \sum_{i=0}^{\infty} h(i)u(k-i), \quad (2-6)$$

where u and y are the input and output of a discrete time signal, respectively and h is the impulse response of the system, $h: \mathbb{N} \rightarrow \mathfrak{R}$, k is the discrete time.

If the impulse response of the system has finite energy, i.e., if:

$$\sum_{k=1}^{\infty} h^2(k) < \infty, \quad (2-7)$$

so h can be approximately represented by a finite-length n , $n > 0$ number of orthonormal functions in the form:

$$h(k) = \sum_{i=1}^n c_i \varphi_i(k). \quad (2-8)$$

where $\varphi_i(k)$, $i = 1, 2, \dots, n$ are the orthonormal function of the basis, n is the number of parameters and c_1, \dots, c_n are scalar weights given by (OLIVEIRA et al., 2011):

$$c_i = \sum_{k=0}^{\infty} h(k) \varphi_i(k). \quad (2-9)$$

As in any series of functions, due the truncation of the series in n terms, there is an error mismatch, which can be made as small as desired just augmenting n , and can be expressed as:

$$\sum_{k=0}^{\infty} \left(h(k) - \sum_{i=1}^n c_i \varphi_i(k) \right)^2 < \epsilon. \quad (2-10)$$

Being $\phi(k) = z\{\varphi[n]\}$.

After all, the relationship between the input signal and output is given by the expansion of h using n orthonormal functions is:

$$\hat{y}(k) = \sum_{i=1}^n c_i \sum_{j=0}^k \varphi_i(j)u(k-j). \quad (2-11)$$

or else:

$$\hat{y}(k) = \sum_{i=1}^n c_i l_i(k). \quad (2-12)$$

being l_i the convolution of input u with the i -est orthonormal function φ at k instant.

Applying the Z transform on Equation (2-12):

$$\hat{Y}(z) = \sum_{i=1}^n c_i \phi_i(z) U(z). \quad (2-13)$$

In fact, OBF can be thought as a generalization of the finite length Fourier series expansion where two filters φ_1 and φ_2 are said to be orthonormal if they satisfy the properties:

$$\begin{aligned} \langle \varphi_1(q), \varphi_2(q) \rangle &= 0; \\ \|\varphi_1(q)\| &= \|\varphi_2(q)\| = 1. \end{aligned} \quad (2-14)$$

Furthermore, being recursive functions (where the i -th function can be written from the $(i - 1)$ -th), orthonormal basis functions can also being described by space-state representation (OLIVEIRA, 1997) which means that every parameter of the basis can be easily estimated using linear estimation algorithms such as least squares (LJUNG, 1987; AGUIRRE, 2007). An all-purpose representation of OBF is given by Equation (2-15):

$$\begin{aligned} l(k+1) &= Al(k) + bu(k), \\ \hat{y}'(k) &= \mathcal{H}(l(k)). \end{aligned} \quad (2-15)$$

where $l(k) = [l_1(k) \dots l_n(k)]^T$ is given by the outputs of the orthonormal filters where $l_i(k) = \sum_{\tau=0}^{\infty} \varphi_i(\tau)u(k-\tau)$ and \mathcal{H} is an static mapping given by a linear or nonlinear combination of the states, depending on the system being described. Both A and b depend only on the orthonormal series of functions chosen.

In this context, over the last decade several orthonormal basis filters (see Equations 2-11 and 2-12) were developed and can be used to build the system dynamics in a format of rational functions. The selection of the appropriate type of filter depends on the dynamical behaviour of the system to be modelled.

So, be $\{\phi_i(z), i = 1, 2, \dots, n\}$ the Takenaka Malmquist basis functions given by (NINNESS; GUSTAFSSON, 1997) on Equation (2-16):

$$\phi_i(z) = \left(\frac{\sqrt{1 - |p_i|^2}}{1 - p_i z^{-1}} \right) \prod_{k=1}^{i-1} \frac{z^{-1} - \bar{p}_k}{1 - p_k z^{-1}}, \quad i = 1, 2, \dots \quad (2-16)$$

where $\{p_i, \bar{p}_i \in \mathbb{C}\}$ are the poles or modes of the model and the correspondent realizations of $\varphi_i(k)$, $i = 1, 2, \dots, n$. in the time domain $k \in \mathbb{N}$ are given by the inverse Z transform of Equation (2-16) and satisfy the orthonormality property from Equation (2-14).

Furthermore $\{\phi_i\}$ is called complete on $l^2[0, \infty)$ space only if $\sum_{i=1}^{\infty} (1 - |p_i|) < \infty$ (HEUBERGER et al., 2005), in this case any finite response such as described in Equation (2-6) can be described with pre-determined accuracy using a finite number of

OBF functions. From the same Equation, the pole p is chosen from a priori knowledge of the system dynamics or by methods developed for optimal selection of the base parameters. Many papers addressed the problem of finding the best pole and then enhance the OBF identification result. For further explanations and examples, find (OLIVEIRA E SILVA, 1995; OLIVEIRA SILVA, 1995; REGINATO; OLIVEIRA, 2007; ROSA et al., 2009).

The realization of Equation (2-16) can assume different approaches depending on the nature of the pole p and they are designed to obtain optimum result depending on the nature and dominant order of the system. For instance, it is called Laguerre functions if p is a real unique value and suitable for first order systems. In other hand, being p a pair of conjugate poles is scope of (WAHLBERG, 1994) when using Kautz filters and its results shows notable performance on solving second order systems.

2.2.1 Laguerre Filters

From Equation (2-16) if $p_i = \bar{p}_i = p$, where $p \in \{\Re: |p| < 1\}$, the orthonormal series of functions are the well-known Laguerre basis, a first-order OBF with one real pole p (WAHLBERG, 1991). Additionally, diagrams for better understanding can be found on (WANG; CLUETT, 2000). From Equation (2-16), the Laguerre filters are given by:

$$\phi_i(k) = \sqrt{1-p^2} \frac{(1-pz)^{i-1}}{(z-p)^i}, |p| < 1. \quad (2-17)$$

where p is the estimated basis functions pole.

Considering $p = 0$, the model from Equation (2-13):

$$\hat{y}(k) = \sum_{i=1}^n c_i u(k-j). \quad (2-18)$$

which is given by the FIR model from impulse response (LJUNG, 1987). So, it can be said that FIR is a particular case of the Orthonormal Basis Functions (NINNESS, 1998).

2.2.2 Kautz Filters

From Equation (2-16) it is assumed $p_{i+1} = \bar{p}_i$ and $p_i = p, \forall i$. By combining the two subsequent functions in order to avoid orthonormal functions with complex impulse response, Kautz functions are defined:

$$\begin{aligned}\Phi_{2i-1}(k) &= \frac{\sqrt{(1-a^2)(a-b^2)}}{z^2 + a(b-1)z - b} g(a, b, z, i), \\ \Phi_{2i}(k) &= \frac{\sqrt{(1-b^2)(z-a)}}{z^2 + a(b-1)z - b} g(a, b, z, i).\end{aligned}\tag{2-19}$$

where:

$$g(a, b, z, i) = \left(\frac{-bz^2 + a(b-1)z + a}{z^2 + a(b-1)z - b} \right)^{i-1}, \tag{2-20}$$

being a and b real parameters related to the pole where $a = -p\bar{p}$ and $b = (p + \bar{p})/(1 + p\bar{p})$.

There are other basis functions that will not be used in the present study. As described by Equation (2-16), one that worth mentioning for further reading is the Generalized Orthonormal Basis Filter, introduced by (HEUBERGER et al., 1995) and notable by being able of describing more complex structures than Kautz and Laguerre functions (NINNESS; GUSTAFSSON, 1997). Additionally, diagrams for better understanding can be found on (WANG; CLUETT, 2000).

2.3 Development of OBF models for nonlinear systems

The development of orthonormal basis functions for linear systems comes from the linear mapping called \mathcal{H} from Equation (2-15), which nothing more than a linear combination of the output of each function, which comes from the expansion of the impulse response of the system through a series of orthonormal filters (CAMPELLO et al., 2007). In this scenario, when it comes about nonlinear systems, the main objective on developing a nonlinear model using OBF is to change the linear mapping for a nonlinear one such that model is capable of describing a nonlinear dynamic.

Hypothetically assuming a Wiener model, which is widely used to represent nonlinear systems, the nonlinear OBF (NOBF) becomes a linear dynamic model between the input u and orthonormal states l_i , $i = 1, 2, \dots$ (find Equation 2-15) followed by a static mapping between the same states and the output \hat{y} (CAMPELLO, 2002; OLIVEIRA et al., 2003, 2012; CAMPELLO et al., 2007).

After all, the static mapping \mathcal{H} realizes an specific structure for the (N)OBF. All nonlinear realizations of this thesis becomes a linear-in-parameters unifying (N)OBF construction in the form:

$$\mathcal{H}(l(k)) = \lambda(k)^T \zeta. \quad (2-21)$$

being $\zeta \in \mathfrak{R}^{\mu \times 1}$ a vector parameter to be estimated and $\lambda \in \mathfrak{R}^{\mu \times 1}$ a regression vector dependent only on the orthonormal states $l(k)$ at time instant k .

2.3.1 OBF-Volterra Models

Beyond many nonlinear system identification techniques available (LJUNG, 1987; AGUIRRE, 2007), the Volterra models have been successfully applied in identification of dynamic nonlinear systems due to its linear-in-parameters structure. First introduced by (WIENER, 1958; VOLTERRA, 1959), Volterra series are one of the most nonlinear models applied in real systems since the first applications of (WIENER, 1958) due to its direct representation between input and output of the system, good results when analyzing random input signals, representation of linear systems as a particularity of nonlinear systems and spread to nonlinear systems concepts and knowledge obtained from linear systems.

From the generalization of the impulse response model first developed for linear systems (SCHETZEN, 1980; DOYLE et al, 1995; BOYD et al, 1985), the Volterra series can be described as given in Equation (2-22), M is the model order, u , y and h_m are the input, output and a m -order kernel being ϵ_m the biggest term in which h_m is not null.

$$y(k) = \sum_{m=1}^M \sum_{k_1=0}^{\epsilon_m} \dots \sum_{k_m=0}^{\epsilon_m} h_m(k_1, k_2, \dots, k_m) \prod_{j=1}^m u(k - k_j). \quad (2-22)$$

Besides the fact of being able to identify nonlinear systems, the Volterra series have some disadvantages. The most important one relies on choosing a feasible number of m functions to represent each kernel (ZHU; BRAZIL, 2005; ZHANG et al., 2006; CAMPELLO et al., 2007; ROSA et al., 2010; BRAGA, 2011). For highly nonlinear systems, the number of kernels to represent the system is too high, reducing the Volterra series applicability and accuracy (ZHU; BRAZIL, 2005; ZHANG et al., 2006; CAMPELLO et al., 2007; ROSA et al., 2010; BRAGA, 2011). With the purpose of improving Volterra model, it is possible to reduce the number of parameters needed by building a combined model using orthonormal basis functions (OBF) where each Volterra kernel is determined as an expansion of different OBF with the same or different number of functions (ROSA et al., 2010; BRAGA, 2011).

Therefore, from Equation (2-22), if $h_m(k_1, k_2, \dots, k_m) = 0$ when $k_m > \epsilon_m \forall i \in \{1, \dots, m\}$) then the kernels are absolutely summable on $[0, \infty)$, which also leads to a stable model that can be developed through OBF (SCHETZEN, 1980; DOYLE et al, 1995; BOYD et al, 1985). Considering that every kernel has the same base functions, a m -dimensional kernel is given by (SCHETZEN, 1980; DOYLE et al, 1995; BOYD et al, 1985):

$$h_m(k_1, \dots, k_m) = \sum_{i_1=1}^{\infty} \dots \sum_{i_m=1}^{\infty} c_{i_1, \dots, i_m} \prod_{j=1}^m \varphi_{i_j}(k_j). \quad (2-23)$$

where φ_i is the i -th orthonormal function and $c_{(\cdot)}$ are the OBF coefficients given by:

$$c_{i_1, \dots, i_m} = \sum_{k_1=0}^{\infty} \dots \sum_{k_m=0}^{\infty} h_m(k_1, k_2, \dots, k_m) \prod_{j=1}^m \varphi_{i_j}(k_j). \quad (2-24)$$

Therefore, the controller structure applied in the VRFT methodology is generalized using the Volterra-OBF model and its output is described as the weighted sum of the outputs from several orthonormal basis functions given by $\varphi_i, i = 1, \dots, m$.

$$y(k) = \sum_{m=1}^M \sum_{i_1=1}^{\infty} \dots \sum_{i_m=1}^{\infty} c_{i_1, \dots, i_m} \prod_{j=1}^m l_{i_j}(k). \quad (2-25)$$

where l_i is the output of the i -th orthonormal filter given by Equation (2-15).

Usually in real and simulation cases it can be used a second order ($M=2$) Volterra-OBF model (BILLINGS, 1980) and only two dimensions orthonormal functions, n_1 and n_2 for kernels of first and second order, respectively (CAMPELLO et al., 2007). Doing that, the Equation (2-25) becomes:

$$\hat{y}(k) = c_0 + \sum_{i_1=1}^{n_1} c_{i_1} l_{i_1}(k) + \sum_{i_1=1}^{n_2} \sum_{i_2=1}^{i_1} c_{i_1, i_2} l_{i_1}(k) l_{i_2}(k). \quad (2-26)$$

where c_0 is a zero order coefficient to fix any constant output value.

From Equation (2-21), being \mathcal{H} a nonlinear static mapping but still a linear-in-parameters representation (CAMPELLO et al., 2007; OLIVEIRA et al., 2012), the Volterra-OBF method becomes a problem of linear-in-parameters estimation. Therefore, as every second order coefficient $c_{i,j}$ and $c_{j,i}$ multiplies the same orthonormal function $l_i l_j$, it can be simplified by using the same coefficient $c_{i,j}$ as presented in Equation (2-26). After all, each $c_{i,j}$ coefficient can be estimated using a least square algorithm by setting $\lambda(k)$ and ζ as

vector parameters if $\zeta \in \mathfrak{R}^{\mu \times 1}$, $\lambda(k) \in \mathfrak{R}^{\mu \times 1}$ and $\mu = (n_2^2 + n_2 + 2n_1 + 1)/2$ (CAMPELLO et al., 2007; OLIVEIRA et al., 2012):

$$\zeta = [c_0 \ c_1 \ \dots \ c_{n_1} \ c_{1,1} \ c_{2,1} \ \dots \ c_{n_2,1} \ c_{n_2,2} \ \dots \ c_{n_2,n_2}]^T \quad (2-27)$$

and

$$\lambda(k) = [1 \ l_1(k) \ \dots \ l_{n_1}(k) \ l_1(k)^2 \ l_2(k)l_1(k) \ l_2(k)^2 \ \dots \ l_{n_2}(k)l_1(k) \ l_{n_2}(k)l_2(k) \ \dots \ l_{n_2}(k)^2]^T \quad (2-28)$$

Different orthonormal basis functions may be used in order to build the system dynamics in a format of rational function, Laguerre (WANG; CLUETT, 2000; WANG, 2009; OLIVEIRA et al., 2011), Kautz (WAHLBERG, 1994) or Takenaka Malmquist, GOBF basis functions (CAMPELLO et al., 2007; OLIVEIRA et al., 2011).

It is important to mention that thought the use of orthonormal basis function to describe the Volterra kernels, an important characteristic from OBF was added to this nonlinear model which regards the additional information about the dynamic behaviour of the system carried by the OBF model, being for instance Laguerre, Kautz or even GOBF functions. Taken together, if the OBF dynamics matches or it is closed to the real system dynamics, the Volterra-OBF convergence is enhanced, which results in lesser parameters used to describe the system behaviour and more accuracy in the transfer function obtained.

2.4 Final Remarks

This Chapter consists of a summary of the System Identification theory on Orthonormal Basis Functions context. It described the functions and mathematical developments of Kautz and Laguerre orthonormal filters and detailed the application of such filters on linear and nonlinear systems. The purpose is to provide an understanding about the modeling structure being proposed and applied in the following Chapters.

3 NEW CONTROL STRUCTURE WITH VIRTUAL REFERENCE USING ORTHONORMAL BASIS FUNCTIONS ON LINEAR SYSTEMS

The Virtual Reference Feedback Tuning (VRFT) design is a non-iterative method that intends to identify a controller from one set of data collected from plant. Although it is a good alternative for controller design, it minimizes parameters in a pre-defined structure of controller. It means that this class of controller must be assigned precisely, otherwise the feedback system does not respond as a reference model. This Chapter generalizes this control structure by adapting the orthonormal basis functions (OBF) on the VRFT theory, with the purpose of improving applicability on linear systems. Two methods are proposed, called herein by direct and non-direct methods. Although the use of any rational orthonormal basis functions are possible in this Chapter it will be applied only Laguerre and Kautz functions. Simulation results are presented to illustrate the effectiveness compared between conventional VRFT and OBF-VRFT for linear plants.

3.1 Introduction

In order to achieve performance with stricter requirements and to control increasingly complex systems, since the 90's many methods have been developed to design the controller without a prior knowledge of the process model, but only with input and output data collected from the plant. Therefore, data-based techniques to design controllers are mainly intended to use the amount of information collected to adjust the parameters of structures previously determined and then meet some performance criteria (GUARDABASSI; SAVARESI, 2000; KARIMI et al., 2004; HUUSOM et al., 2011).

Among many design methods based on data controllers, the Virtual Reference Feedback Tuning or VRFT has the great advantage of working with only one set of data from the plant, which means a single intervention for experiments. Initially proposed by (GUARDABASSI; SAVARESI, 2000), the method has been widely studied since then. Among many papers, find (CAMPI et al., 2002; CAMPESTRINI et al., 2011; FABRICIO; BAZANELLA, 2012).

The VRFT technique determines the controller so that the closed-loop behavior is as close as possible to a reference model. Setting the desired closed-loop performance by a reference model is an advantage of VRFT against traditional techniques whose

specifications are usually chosen empirically or based on a limited and simplistic structure (CAMPESTRINI, 2010). It is worth mentioning that, although this Chapter addresses the VRFT method for linear systems, it can also be applied on nonlinear systems – find Chapters 4 and (GUARDABASSI; SAVARESI, 1997; NIJMEIJER; SAVARESI, 1998; HOOG, DE, 2001; KANSHA et al., 2008).

After taking everything into account, it can be said that three initial data are needed in VRFT routine: A set of input and output from the plant (experiment), the desired closed-loop behavior of system (reference model) and a reasonable model structure for the controller.

The definition of Model and Model Structure is given by (LJUNG, 1987):

- Model is a relationship between observed quantities and it allows prediction of proprieties behaviors of the studied object;
- Model Structure or Model Set is a set of models that can be parameterized by a finite-dimensional parameter set.

So, in the pre-definition of a control structure during identification step of the VRFT technique it is necessary to define a model set C^* that contains a finite number of models C with parameter vectors θ belonging to D_C in the form:

$$C^* = \{C(\theta) | \theta \in D_C\} \quad (3-1)$$

In the VRFT context, there is an ideal set of controller which is able to solve the control design problem. Nevertheless, there are cases in which the chosen set does not belong to the set of ideal controllers, mainly because the plant structure to be controlled is not known a priori. In such situations, even if C exists, the estimated parameters for the controller can converge, but the closed-loop response falls short of the specified (GUARDABASSI et al., 2007).

So, despite having the advantage of being able to be parameterized linearly (CAMPESTRINI et al., 2011), the ultimate success of the VRFT technique is dependent on this class of models chosen to represent the controller whose parameters are selected using a system identification procedure (CAMPI et al., 2002).

In order to address this problem, several works, such as (GUARDABASSI; SAVARESI, 2000; LECCHINI et al., 2002; KANSHA et al., 2008; CAMPESTRINI, 2010; NEUHAUS, 2012), applied efforts to find an optimized model class C during step of experiments in order to provide a suitable error of convergence of parameters θ .

All these factors justifies the search for different modeling techniques, linear in parameter, which are able to improve the VRFT method. In this Chapter, it is analysed the orthonormal based functions (OBF) models for VRFT control design (HEUBERGER et al., 1995). Compared to other advance techniques such as models constructed using well-known auto-regressive with exogenous inputs – ARX – structure (LJUNG, 1987; SJÖBERG; LJUNG, 1995), OBF models, as described in (CAMPELLO et al., 2007) has some advantages:

- Natural decoupling of multiple outputs in multivariate models and a set of statistical properties favorable to numerical estimation of linear models in the parameters via least-squares algorithm;
- It is not necessary to know the past I/O terms from the system, whose procedures of determination is not trivial, particularly on the nonlinear case;
- There is no auto-regressive effect, which generally increases the sensitivity regarding the model order and generates feedback errors, damaging the quality of long-range prediction (OLIVEIRA et al., 2011).

In other hand, it is worth mentioning the finite impulse response (FIR) model, in which the estimated output is represented only in terms of past samples of the input. The absence of output recurrence is a common feature between FIR and OBF series, but the number of terms in input regression vector, thus the model parameters, of the FIR model is larger especially when representing slow dynamics. In the OBF case, each orthonormal function composes a state vector that, thought linear combination of these states, can describe the model output. The parameters of such linear combination are the model parameters and their quantity is smaller than FIR for the same level of approximate modeling error. Some comparisons and applications of OBF series in control systems can be found in (WANG; CLUETT, 2000; REGINATO; OLIVEIRA, 2007; WANG, 2009).

In this context, this Chapter contains a proposal to use models with structure formed by orthonormal basis functions on parameterization of controllers with VRFT-based design for linear systems. It aims to decrease the sensitivity of the project VRFT front the prior selection of controller structure.

Two different approaches to identify the OBF controller will be used. If the impulse response of the system is available, the OBF coefficients can be calculated analytically. So called *non-direct* as the controller is given by the inverse of an OBF structure, the initial data is given by the impulse response of the plant. This parametric approach, although

simpler and mathematically grounded, may not be effective in real problems. The reason is that the impulse response of the system, when available, may contain noise and/or unmodelled dynamics. A second approach is to consider each OBF coefficient as parameter to be estimated numerically using data from the I/O system, which can be performed in a simple way using linear estimation algorithms (e.g. least squares) (LJUNG, 1999; AGUIRRE, 2004). So, the second method called *direct* intends to enhance the application of OBF functions on VRFT controller identification by developing a direct minimization of the control structure given a normal distributed with zero average signal as initial input data.

This Chapter is structured as follows. The Section 3.2, describes the classical approach of the VRFT method for linear systems. In Section 3.3 and 3.4, there are two different proposals for a controller with structure formed by OBF on VRFT technique using respectively a direct approach and a particular non-direct analytical solution. In Section 3.5 both proposed strategies are presented and simulated in a case study and then, in Section 3.6, the Chapter is concluded.

3.2 The VRFT Technique

The Virtual Reference Feedback Tuning is a non-iterative method that consists on finding parameters of the controller in order to get a feedback model that behaves like a reference model. As discussed before, the main focus of this Chapter is to address the VRFT design for linear systems.

The main characteristic of the VRFT design is to turn the controller computation task into a system identification procedure for estimating C with parameters θ , so that the closed-loop system behaves as near as possible to the pre-specified model, T . Also called as a *one shot* or *direct* data-based method, the VRFT directly selects the controller without preliminary use of data to identify the model of the plant. The controller selection is only based on a given batch of data and a selected structure (CAMPI and SAVARESI, 2006).

Given the Figure 3-1, suppose a closed-loop system where the transfer function of the plant, represented by G is not known and a reference model given by T specifies the desired behavior for the closed-loop system. In the same Figure, u and y are, respectively, the input and output data already known from a first experiment with noise input v . In

addition \bar{r} is the virtual reference output, obtained through the inverse of the reference model T^{-1} and y .

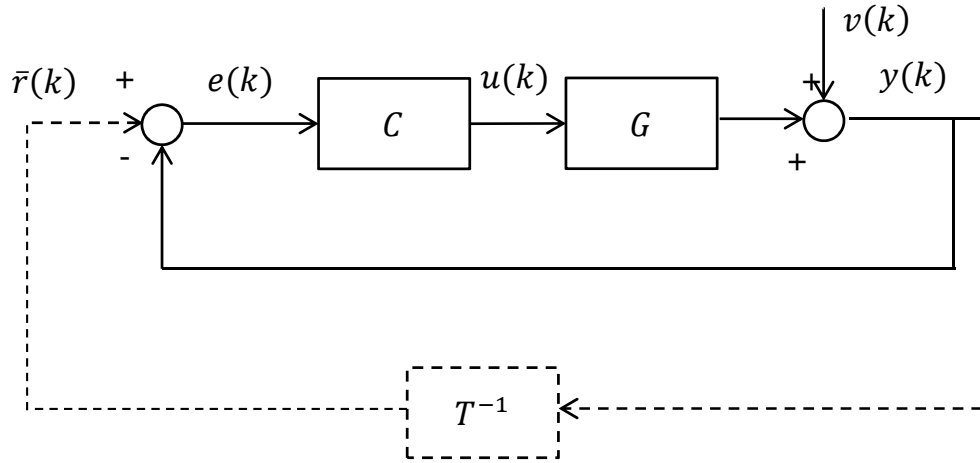

FIGURE 3-1. UNITARY FEEDBACK CONTROL SYSTEM, BEING T THE DESIRED DYNAMICS.

Assuming that one set of I/O signals $Z = \{u(k), y(k)\}_{k=1}^N$ is collected from the process G in a time-domain experiment. Then, the controller I/O signals are given by $Z' = \{e(k), u(k)\}_{k=1}^N$, where:

$$e(k) = \bar{r}(k) - y(k) \quad (3-2)$$

and:

$$\bar{r}(k) = T^{-1}(q)y(k), \quad (3-3)$$

where:

$$T(q) = \frac{C(q, \theta)G(q)}{1 + C(q, \theta)G(q)}. \quad (3-4)$$

The VRFT technique sets C such as the closed-loop system output, when the reference signal is \bar{r} , is equal to measured y from Z . Note that \bar{r} it is not a real reference signal but it is just calculated to generate the controller input signal.

As Z' is known, the task of estimating the controller parameters θ is reduced to a time-domain system identification problem. Based on the process output signal and the reference signal \bar{r} the goal is to find the transfer function between e and u and consequently the controller transfer function. After all, it can be said that the system is reduced to a problem of dynamic model identification in which, if the input is e then the output is u (CAMPI et al., 2002; KANSHA et al., 2008; FABRICIO; BAZANELLA, 2012). As result, the identification of the controller reduces to minimize the objective function:

$$\min_{\theta} J(\theta)$$

$$J(\theta) = \frac{1}{N} \sum_{k=1}^N [u(k) - C(q, \theta)e(k)]^2 \quad (3-5)$$

After all, as in every systems identification problem, the new goal is to determine a proper structure of model C^* containing specific models C given from vectors of parameters θ belonging to the set D_C , so that (LJUNG, 1987):

$$C^* = \{C(\theta) | \theta \in D_C\} \quad (3-6)$$

Consequently, the controller class selection on is one of the principal challenges of the VRFT project. In several works such as (GUARDABASSI; SAVARESI, 2000; KANSHA et al., 2008; CAMPESTRINI, 2010; NEUHAUS, 2012) the structure of the controllers was determined previously in step of experiments and it was parameterized based on a pre-defined structure, as given by Equation (3-7):

$$C(q, \theta) = \rho^T(q)\theta, \quad (3-7)$$

being $\rho(q) = [\rho_1(q) \rho_2(q) \rho_3(q) \dots \rho_n(q)]^T$ a vector of linear discrete-time transfer functions and $\theta = [\theta_1, \theta_2, \dots, \theta_n]^T$ the vector of parameters to be estimated. I.e. for a PI controller, the controller class $C(q, \theta)$ is given by:

$$\rho_1(q) = \frac{q}{q-1};$$

$$\rho_2(q) = \frac{1}{q-1}.$$
(3-8)

Thus:

$$C(q, \theta) = \frac{\theta_1 q + \theta_2}{q-1},$$

or, in the case of a PID:

$$\rho_1(q) = \frac{q^2}{q(q-1)};$$

$$\rho_2(q) = \frac{q}{q(q-1)};$$

$$\rho_3(q) = \frac{1}{q(q-1)}.$$
(3-9)

Thus:

$$C(q, \theta) = \frac{\theta_1 q^2 + \theta_2 q + \theta_3}{q(q-1)}.$$

In such situations where the controller is assumed in advance and it cannot provide the ideal controller, due to some bad numeric conditioning can occur and/or the calculated controller may not meet the desired performance.

That is why, in order to minimize such drawbacks and turn the controller determination a more achievable task, this Chapter presents the VRFT-OBF method, where the controller class is described and generalized as a series of orthonormal functions.

3.3 Control Structure for VRFT using Orthonormal Basis Functions: a direct approach

In this Section, the controller synthesis based on VRFT technique for linear systems is derived. Therefore C , G and T in Figure (3-1) are assumed linear systems, defined in terms of rational transfer functions on the shift operator q . As shown in Section (3-2), an ideal controller C , derived by the VRFT technique, is the one whose closed-loop system behaves as the reference model T , or the one that generates the plant input u when the controller input is e , where e is given by Equation (3-2).

Assuming G linear and the data set $Z = \{e(k), u(k)\}_{k=1}^N$ known from Equations (3-2) and (3-3), the controller synthesis is reduced to find θ that minimizes the following objective function:

$$\min_{\theta} J(\theta)$$

$$J(\theta) = \frac{1}{N} \sum_{k=1}^N [u(k) - C(q)e(k)]^2 \quad (3-10)$$

To assure steady-state zero error for step inputs, it is necessary $C(q, p, \theta)$ to have at least one pole equal one. Therefore, to assure the existence of such pole, the output of the OBF controller structure is changed as described in the Figure (3-3) and Equation (3-27).

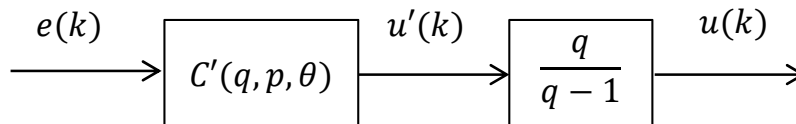

FIGURE 3-2. FILTERED u INPUT ON DIRECT METHOD.

where $\theta = \{\theta_0, \theta_1, \dots, \theta_N\}$ are the parameters of the model series expansion, p represents the basis functions dynamic and q is the shift operator.

The basis functions dynamic p is represented in OBF structure by a value defined after a linear search procedure as described in (OLIVEIRA et al., 2003) and chosen by its lower residual energy of estimation (WANG; CLUETT, 2000).

So, the final controller becomes:

$$C(q) = C'(q, p, \theta) \left(\frac{q-1}{q} \right) \quad (3-11)$$

where:

$$C'(q, p, \theta) = c_0 + \sum_{i=1}^n c_i \Phi_i(q, p). \quad (3-12)$$

Therefore, a new I/O data Z' can be derived as $Z' = \{e(k), u'(k)\}_{k=1}^N$. From Z' , the system identification problem for the controller synthesis can be rewritten as:

$$\begin{aligned} & \min_{\theta} J(\theta) \\ J(\theta) &= \frac{1}{N} \sum_{k=1}^N \left[u'(k) - C'(q, p, \theta) e(k) \right]^2 \end{aligned} \quad (3-13)$$

3.4 Control Structure for VRFT using Orthonormal Basis Functions: a non-direct approach

As presented in Section 3.2 and 3.3, an ideal controller defined by the VRFT technique is one whose closed-loop system behaves as the reference model T , or, in other point of view, it is the one whose transfer function describes the plant input u given an input e , such that:

$$e(k) = \bar{r}(k) - y(k), \quad (3-14)$$

being \bar{r} given by Equation (3-3) and y is the output of the plant from the unique set of data available.

Thus, in the non-direct approach proposed in this Chapter, it is assumed that the initial set of data (u and y) are formed by the impulse response of the plant to G and the identification of the controller is done from I/O data set $Z = \{u(k), e(k)\}_{k=1}^N$, from Figure (3-1) and Equation (3-22). The following synthesis, represented by Figure (3-2), reduces to find θ which minimizes the objective function from Equation (3-16):

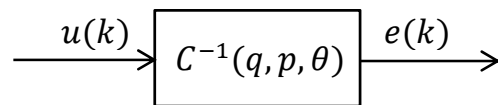

FIGURE 3-3. INVERSE OF THE OBF CONTROLLER ON NON-DIRECT OBF-VRFT METHOD.

where, from Figure (3-1) and (3-2):

$$e(k) = C^{-1}(q, \theta) u(k), \quad (3-15)$$

and

$$\min_{\theta} J(\theta) \quad (3-16)$$

$$J(\theta) = \frac{1}{N} \sum_{k=1}^N \{e(k) - C^{-1}(q)u(k)\},$$

with

$$C^{-1}(q, p, \theta) = \theta_0 + \sum_{i=1}^N \theta_i \phi_i(q, p). \quad (3-17)$$

where $\theta = \{\theta_0, \theta_1, \dots, \theta_N\}$ are parameters of a series expansion of the controller inverse model by using the rational orthonormal basis functions $\phi_i(q, p)$. p represents the basis functions dynamic and q is the shift operator.

Alternatively, u may be an impulse signal so e becomes the impulse response of C^{-1} . According to Section 3.3, a condition in this case is that if e has finite memory, so the error in permanent regime is zero. After all set, the impulse response e can be described using orthonormal basis functions as follows:

$$e(k) = c_0 \delta(k) + \sum_{i=1}^{\infty} c_i \varphi_i(k), \quad (3-18)$$

and:

$$e(k) = \sum_{i=1}^n c_i \varphi_i(k) u(k), \quad (3-19)$$

$$E(z) = \sum_{i=1}^{\infty} c_i \Phi_i(z) U(z), \quad (3-20)$$

and finally:

$$E(z) = C^{-1}(z)U(z). \quad (3-21)$$

So it is possible to describe e through the orthonormal basis functions, then obtain the transfer function of C^{-1} and later C .

3.5 Simulation Examples

In this Section it will be presented two simulation studies in order to illustrate the advantages of using an OBF structure to identify the controller from data given by the VRFT technique. Both classical and OBF-VRFT control structures are presented to compare the results under different number of filters. Furthermore, sub-Section 3.5.1 and 3.5.2 presents examples to illustrate the direct, and then, non-direct approaches.

3.5.1 A direct approach

At this first moment, every controller tuning is directly identified through the input signal e and output u' as well explained in the Section 3.3.

Thus, considering the G plant from Figure (3-1) and a desired behavior T where:

$$G(q) = \frac{0.20(q - 0.80)}{(q - 0.20)(q - 0.70)} \quad (3-22)$$

and:

$$T(q) = \frac{0.36q}{(q - 0.40)^2} \quad (3-23)$$

Given a set of I/O data from the experiment, u and y where y is not affected by a disturbance signal, it is possible to calculate the tracking error signal e and the filtered input u' given by Equation (3-2) and Figure (3-3). Both signals as well the original input data u can be found in the Figure (3-7) where u , u' and e are presented.

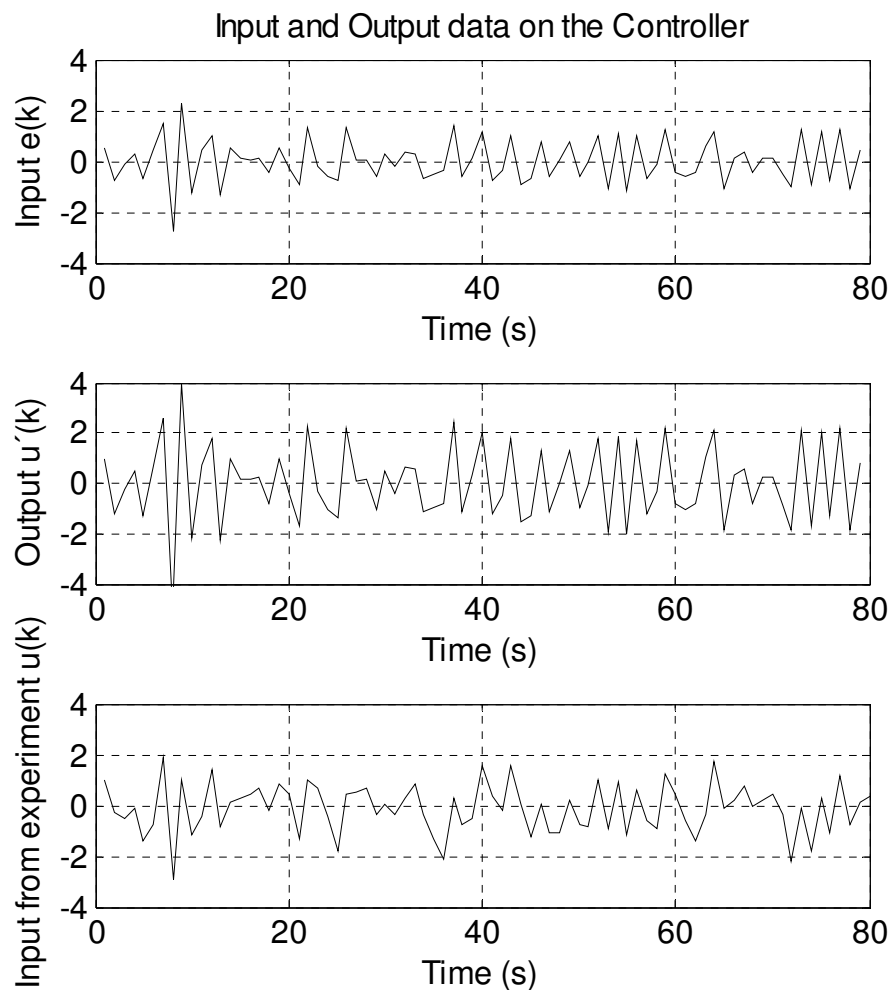

FIGURE 3-4. FIRST CHART: INPUT OF THE CONTROLLER - e ; SECOND CHART: OUTPUT u' ; THIRD CHART: REAL INPUT FROM EXPERIMENTS u .

As seen in Figure (3-4), with absolute amplitude no bigger than four (and normal distribution behaviour with zero mean average) u can be implemented in a real situation.

Then, the VRFT technique is both applied using a predefined class of controllers which does not contain the ideal structure. From Equation (3-6), C is given by:

Control Structure:

$$C(q, \theta) = \frac{\theta_1 q^2 + \theta_2 q + \theta_3}{q(q-1)} \quad (3-24)$$

The estimated parameters from Equation (3-24) and $\{e, u\}$ data gives the controller:

$$\theta = [1.7860 \quad -0.09030 \quad 0.0906]^T$$

$$C(q) = \frac{1.786q^2 - 0.09030q + 0.0906}{q(q-1)} \quad (3-25)$$

In figures (3-5) it is presented the expected and real output signal u' estimated using the classical approach of VRFT technique and a pre-defined structure C . A higher accuracy at identification step is directly related to the quality of results on closed-loop system. So, when there is no noise in the system, every identification step is greatly performed and even the PID controller has a good result up to this point.

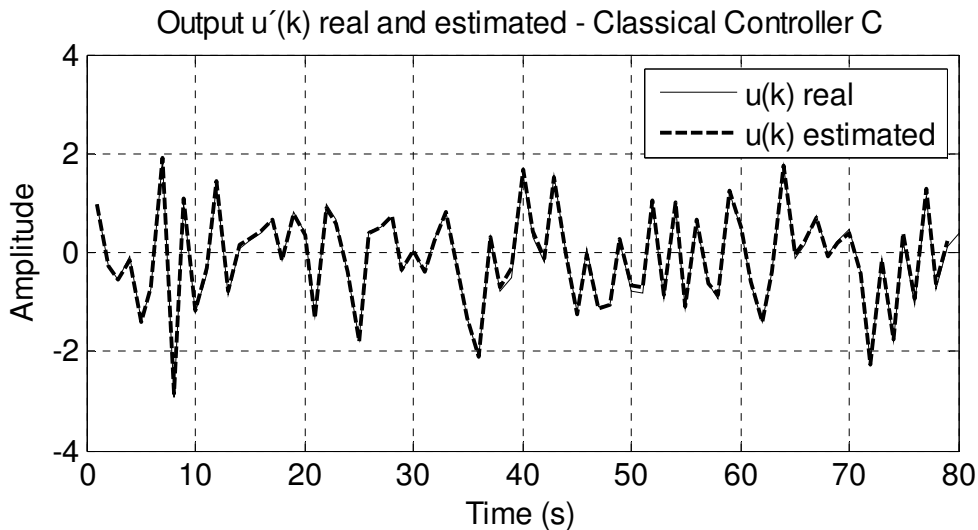

FIGURE 3-5. ESTIMATION RESULT USING CLASSICAL VRFT APPROACH WITH PRE-DEFINED CONTROL STRUCTURE, NO NOISE INPUT.

In the sequence, in order to validate the new way to identify the controller using the VRFT technique, a generalized class of structures written by series of orthonormal basis functions are used. The controller is obtained using four Laguerre and Kautz filters and their results are compared under noisy-free system (in both situations, the pole p is

defined after a linear search procedure as described in (OLIVEIRA et al., 2003) and chosen by its lower residual energy of estimation) (WANG; CLUETT, 2000).

The figures (3-6) and (3-7) present the expected and real output signal u' as well real signal u estimated using the OBF Laguerre and OBF Kautz models without noise input, respectively. Equations (3-26) and (3-27) contains the estimated parameters for both OBF models, respectively:

$$\{c_i\}_{i=1}^6 = \{0.2171 \ 0.1115 \ 0.01100 \ 0.01810 \ 0.0000 \ 6.900 \times 10^{-3}\} \quad (3-26)$$

$$\{c_i\}_{i=1}^6 = \{0.1005 \ 0.1345 \ 0.08790 \ 0.05230 \ 0.01070 \ 9.000 \times 10^{-3}\} \quad (3-27)$$

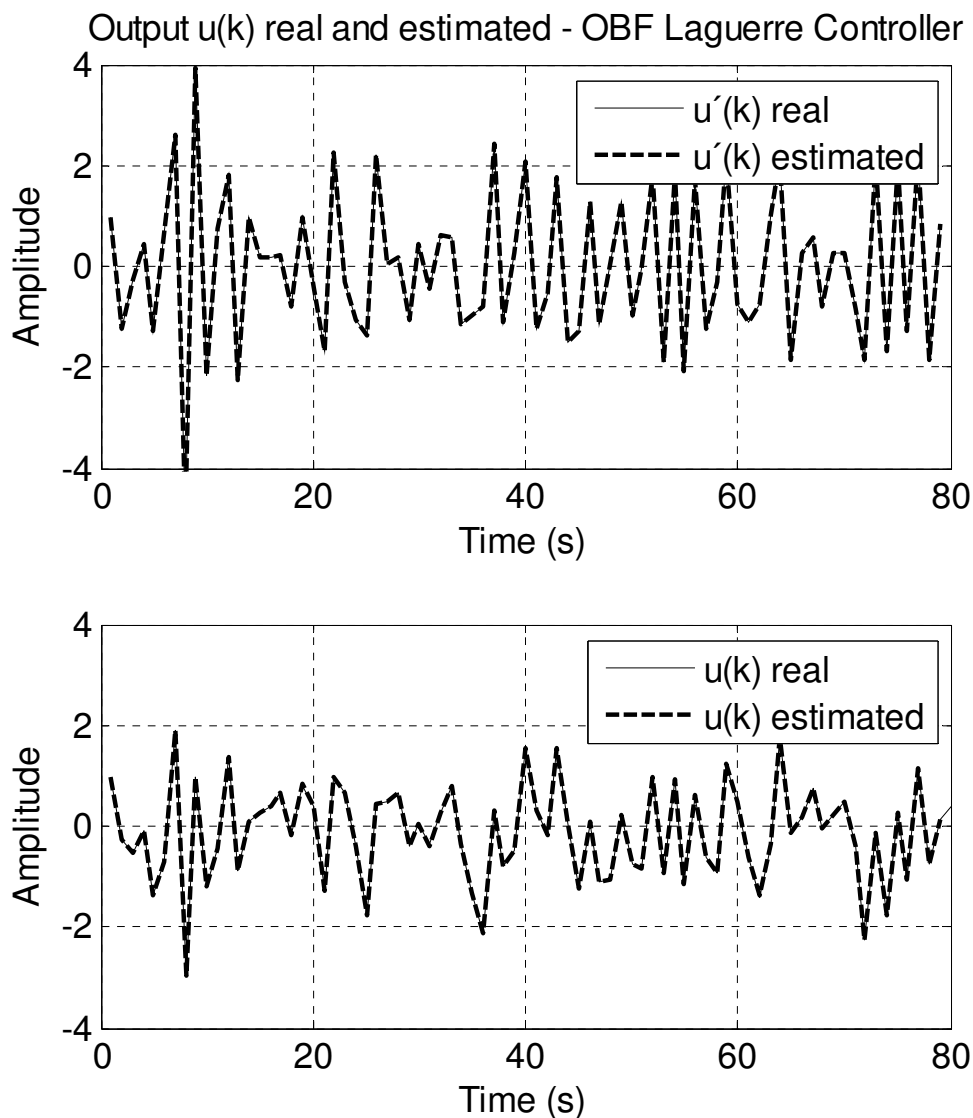

FIGURE 3-6. ESTIMATION OF u AND u' USING OBF LAGUERRE CLASS OF CONTROLLER. SYSTEM WITHOUT NOISE INPUT; $N=6$.

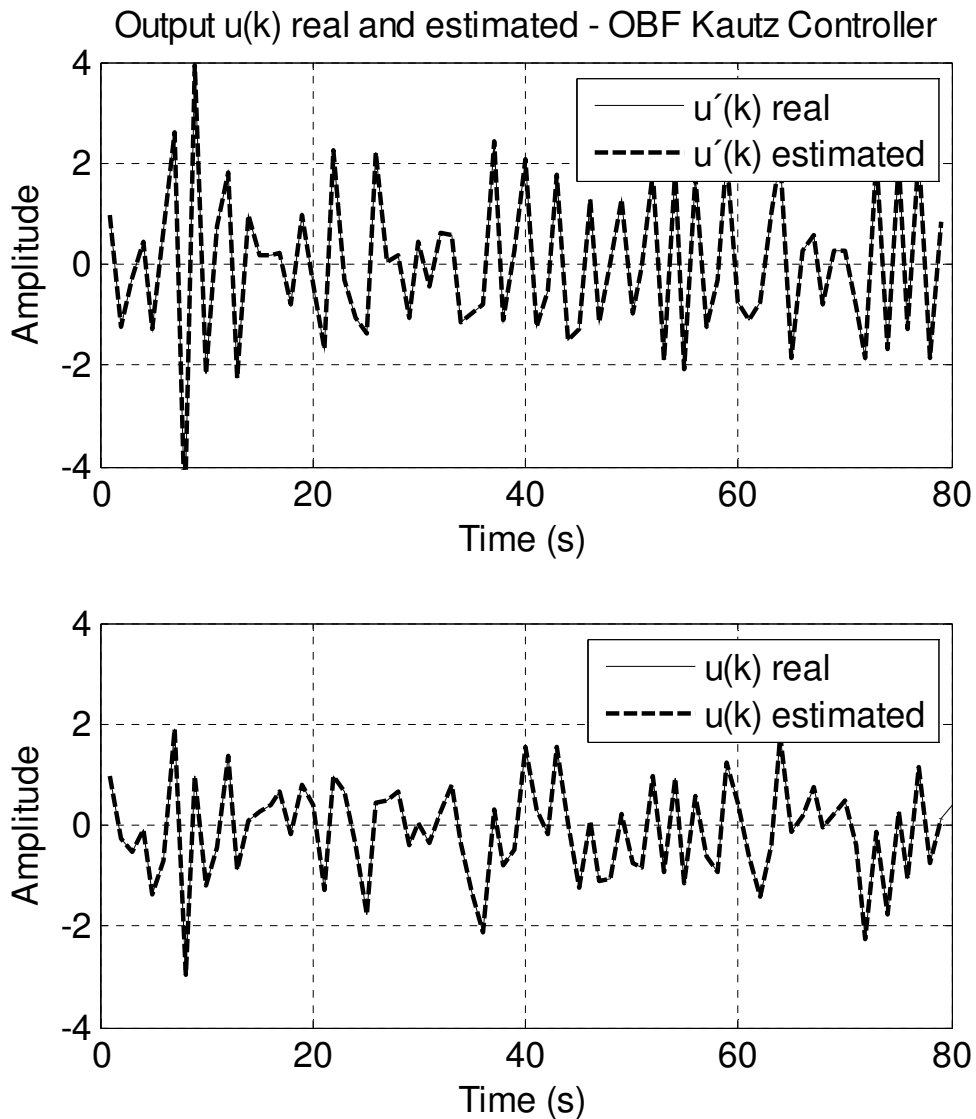

FIGURE 3-7. ESTIMATION OF u' AND u USING OBF KAUTZ CLASS OF CONTROLLER. SYSTEM WITHOUT NOISE INPUT; $N=6$.

For better visualization and statistical comparison between the different models used, the Figure (3-8) shows the distribution of estimation error of the u' signal for both OBF Laguerre and OBF Kautz results earlier presented. It is possible to conclude that the distribution of the combined standard uncertainty tends towards a normal (or gaussian) with standard deviation of 1.302×10^{-3} for Kautz and 2.535×10^{-3} for Laguerre models.

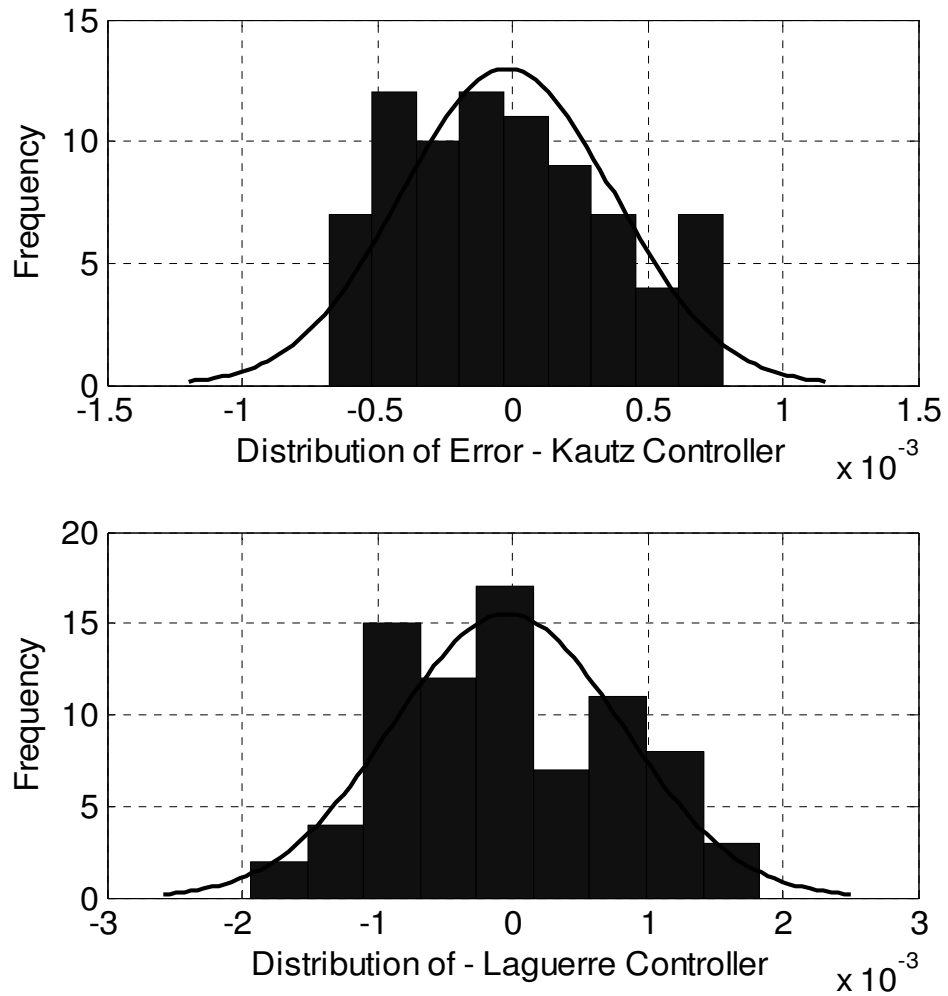

FIGURE 3-8. ERROR HISTOGRAM FROM ESTIMATION OF u USING OBF LAGUERRE AND KAUTZ CLASS OF CONTROLLER; $N=6$.

Furthermore, given a set of I/O data from the experiment $\{u, y\}$ and considering a disturbance signal on the output y , where $v \in \mathcal{N}_{iid}(0, \sigma^2)$ and $\sigma = 0.1000$, it is possible to calculate the tracking error signal e and the filtered input u' given by Figure (3-1). Both signals as well the original input data u can be found in the Figure (3-9) where u , u' and e are presented.

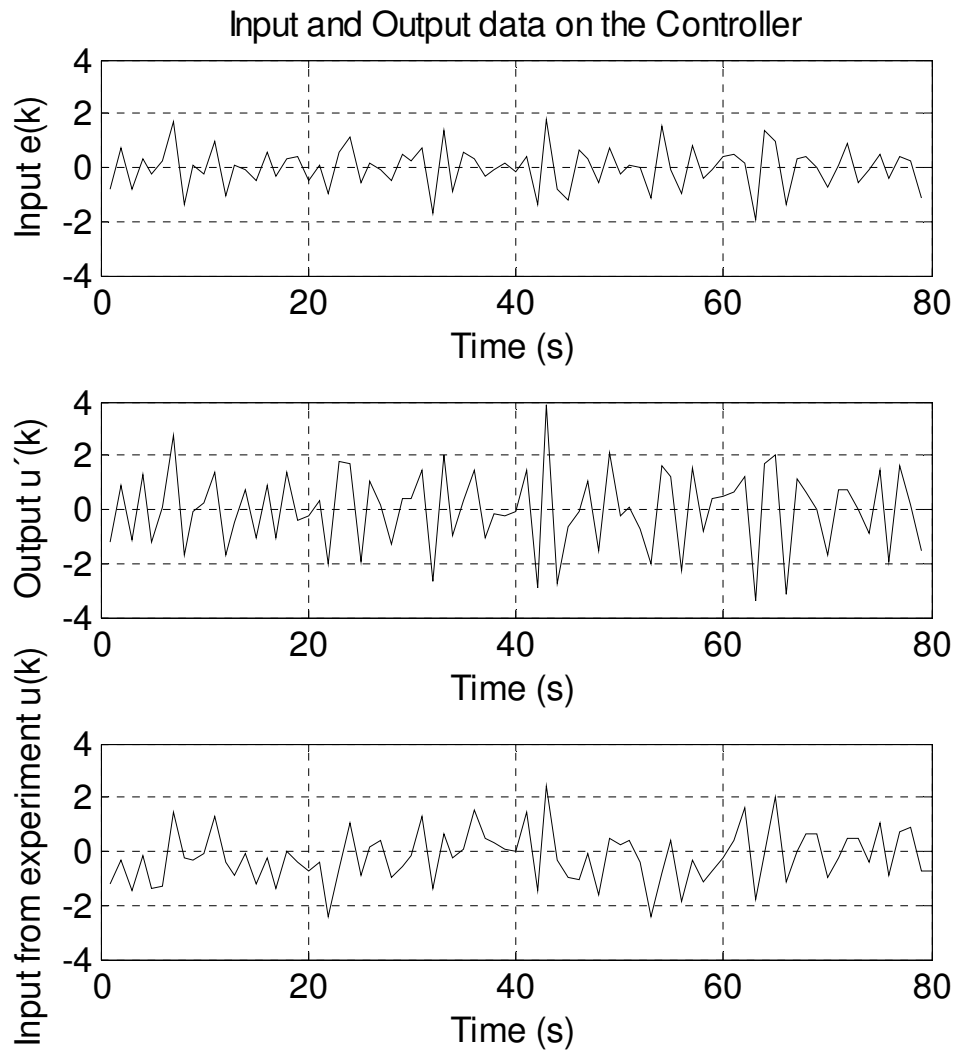

FIGURE 3-9. FIRST CHART: INPUT OF THE CONTROLLER - e ; SECOND CHART: OUTPUT u' ; THIRD CHART: REAL INPUT FROM EXPERIMENTS u .

With absolute amplitude no bigger than four (and with normal distribution behaviour with zero mean average), the u signal proposed in the system is capable of being implemented in a real situation.

From Equation (3-6) and $\{e, u\}$ data, the estimated parameters gives the controller:

$$\theta = [1.489 \quad -0.1514 \quad 0.1293]^T$$

$$C(q) = \frac{1.489q^2 - 0.1514q + 0.1293}{q(q-1)} \quad (3-28)$$

In figures (3-10), it is presented the expected and real output signal u' estimated using the classical approach of VRFT technique and a pre-defined structure C . A higher accuracy at identification step is directly related to the quality of results on closed-loop system. So, in this case when there is noise in the system, the identification step

performance presents a substantial deviation value that can be seen in the following Figure.

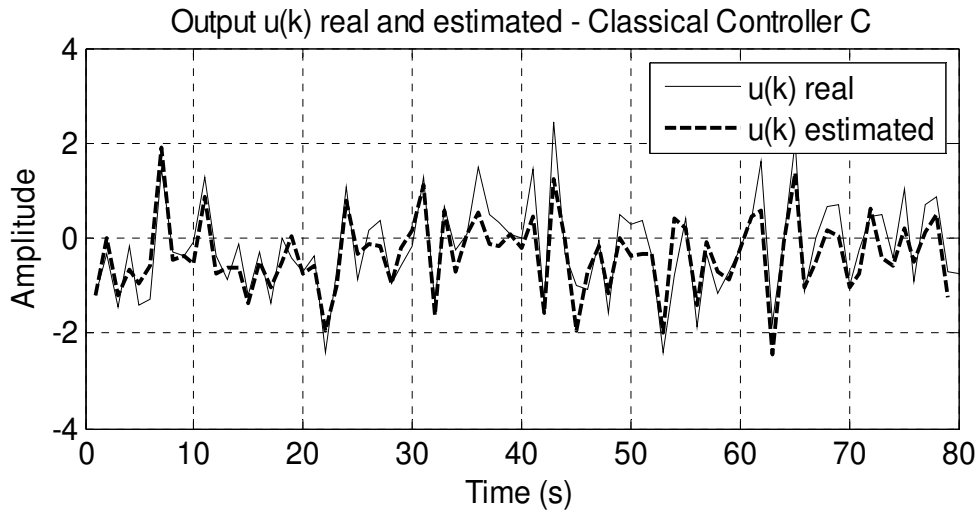

FIGURE 3-10. ESTIMATION RESULT USING CLASSICAL VRFT APPROACH WITH PRE-DEFINED CONTROL STRUCTURE, NOISE WITH 0.1000 STANDARD DEVIATION.

In this way, through the Laguerre and Kautz functions, it is estimated the output u' in order to obtain the controller C using six ($n = 6$) filters for both OBF Laguerre and Kautz functions. The estimated and real data of u' can be compared in figures (3-11), (3-12) to (3-14) to the PID controller presented in Equation (3-28). Equations (3-29) and (3-30) contains the estimated parameters for both OBF models:

$$\{c_i\}_{i=1}^6 = \{0.1678 \ 0.1847 \ 0.1043 \ -0.03570 \ -0.03250 \ -1.00 \times 10^{-4}\} \quad (3-29)$$

$$\{c_j\}_{j=1}^6 = \{0.1297 \ 0.2112 \ 0.1790 \ 9.70 \times 10^{-3} \ 0.0000 \ 0.0875\} \quad (3-30)$$

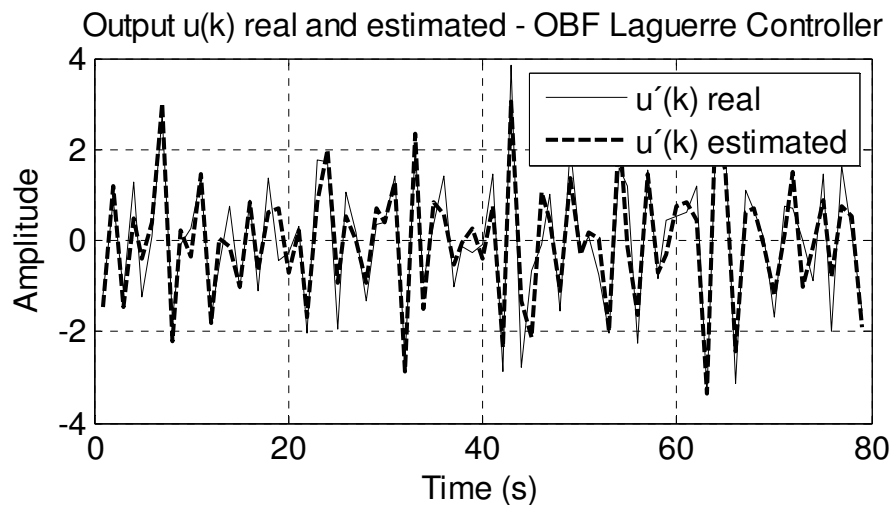

FIGURE 3-11a. ESTIMATION OF u AND u' USING OBF LAGUERRE CLASS OF CONTROLLER, $N = 6$ FILTERS USED, NOISE WITH 0.1000 STANDARD DEVIATION.

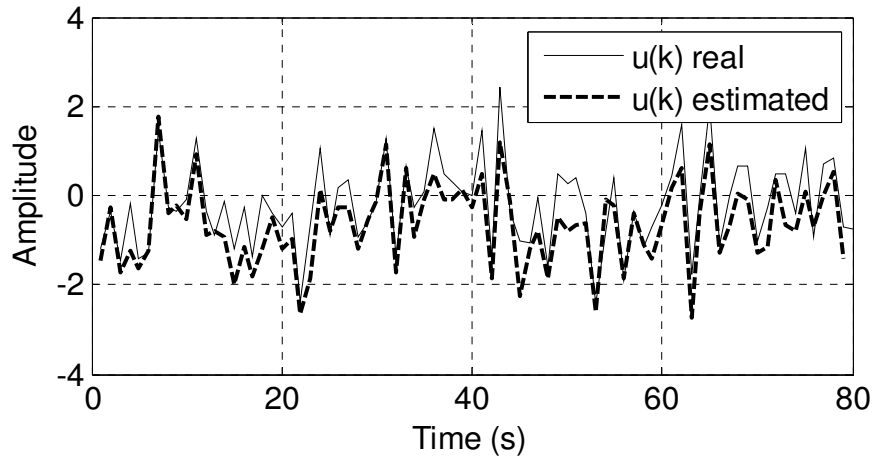

FIGURE 3-11b. ESTIMATION OF u AND u' USING OBF LAGUERRE CLASS OF CONTROLLER, $N = 6$ FILTERS USED, NOISE WITH 0.1000 STANDARD DEVIATION.

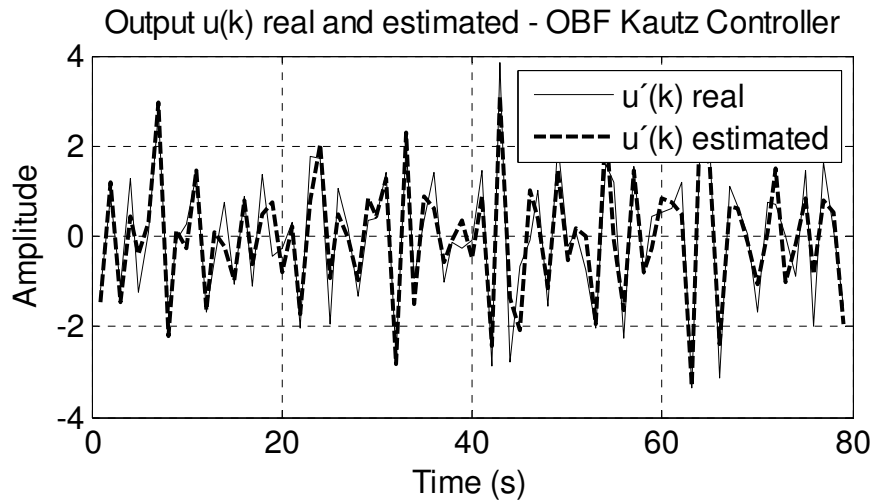

FIGURE 3-12. ESTIMATION OF u' USING OBF KAUTZ CLASS OF CONTROLLER, $N = 6$ FILTERS USED, NOISE WITH 0.1000 STANDARD DEVIATION.

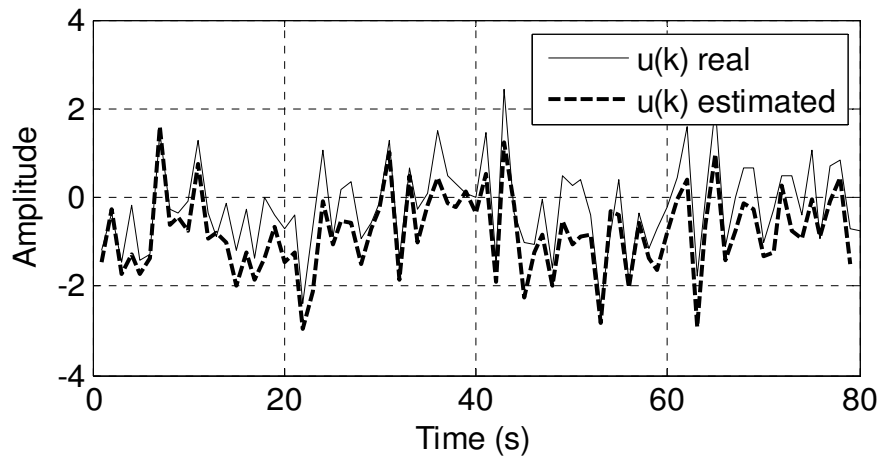

FIGURE 3-13. ESTIMATION OF u USING OBF KAUTZ CLASS OF CONTROLLER, $N = 6$ FILTERS USED, NOISE WITH 0.1000 STANDARD DEVIATION.

For better visualization and statistical comparison between the different models used, the Figure (3-14) shows the distribution of estimation error of the u' signal for both OBF Laguerre and OBF Kautz results earlier presented. It is possible to conclude that the distribution of the combined standard uncertainty tends towards a normal (or gaussian) with standard deviation of 1.836 on Kautz and 1.852 for Laguerre identification.

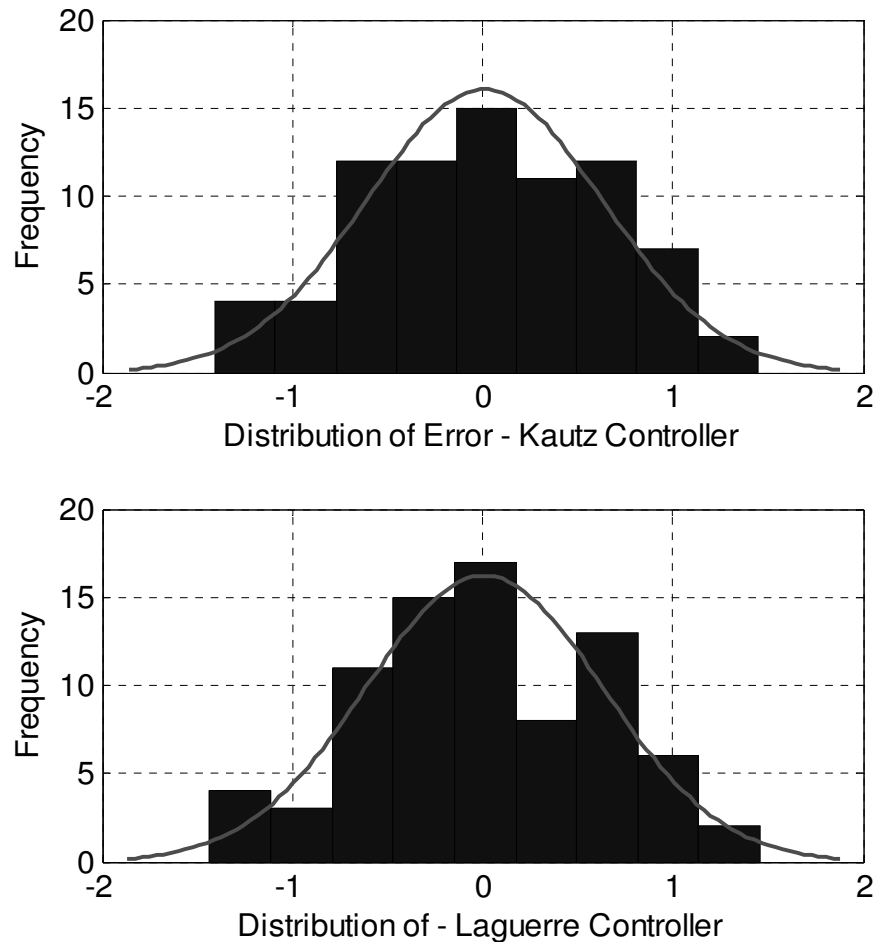

FIGURE 3-14. ERROR HISTOGRAM FROM ESTIMATION OF u USING OBF LAGUERRE AND KAUTZ CLASS OF CONTROLLER; $N=6$.

When noise input is inserted on the system, it is remarkable the misbehavior of the classical VRFT approach facing the estimated and real $\{u, u'\}$ data. To deeper understand the OBF solution, after six filters, four functions were used to demonstrate the effectiveness of the proposed method facing the consequences of lesser number of Laguerre and Kautz filters under noisy system. The mean square error of the resulting controller during identification step is smallest when Kautz functions are applied instead of OBF Laguerre.

Lastly, Figures (13-15) and (3-16) show the results considering four OBF functions for both OBF Laguerre and OBF Kautz functions.

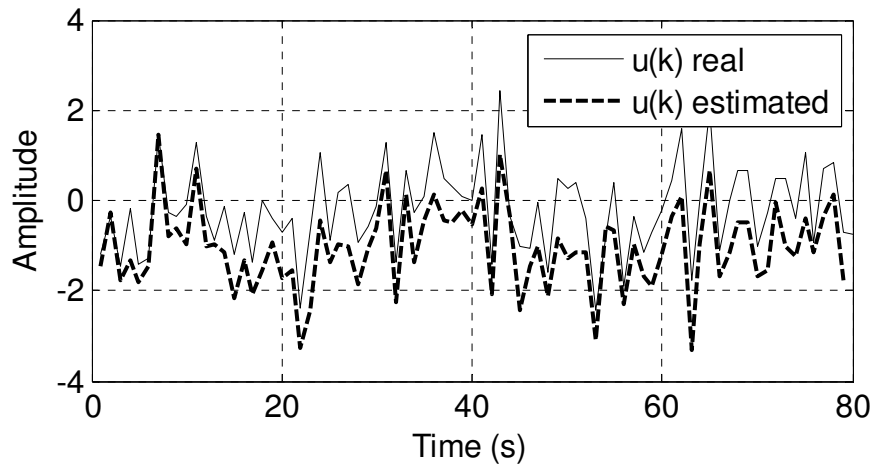
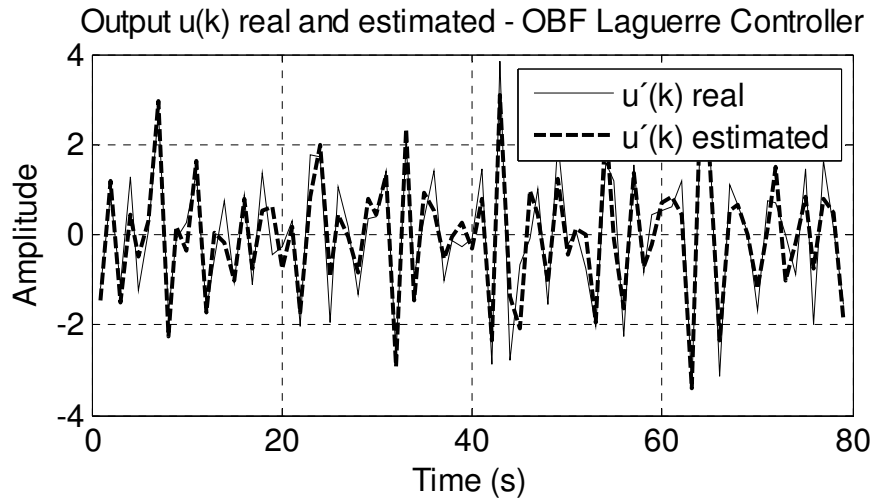

FIGURE 3-15. ESTIMATION OF u AND u' USING OBF LAGUERRE CLASS OF CONTROLLER, $N = 4$ FILTERS USED, NOISE WITH 0.1000 STANDARD DEVIATION.

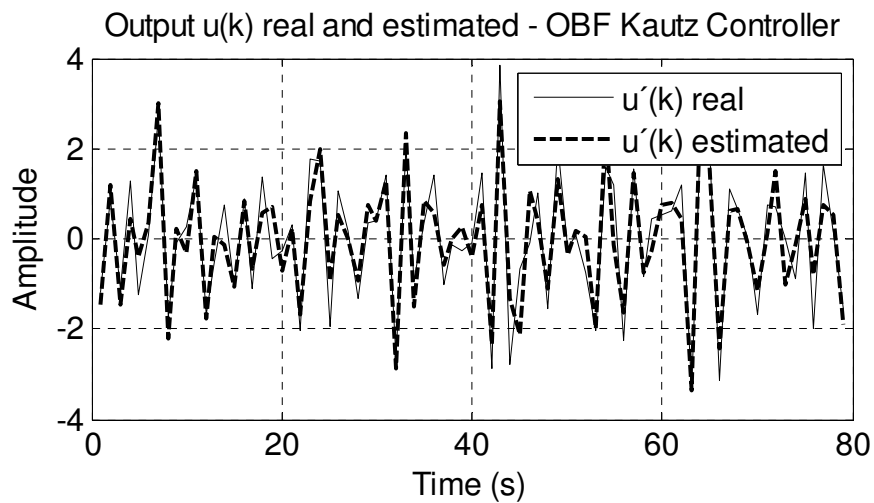

FIGURE 3-16a. ESTIMATION OF u AND u' USING OBF KAUTZ CLASS OF CONTROLLER, $N = 4$ FILTERS USED, NOISE WITH 0.1000 STANDARD DEVIATION.

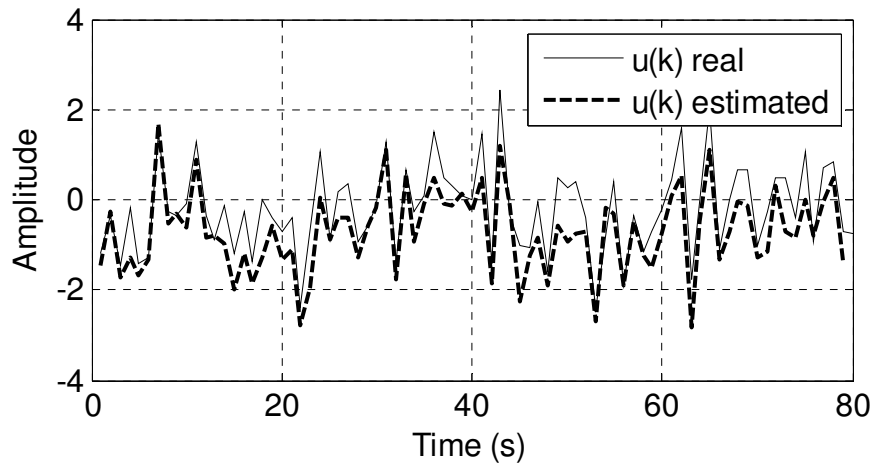

FIGURE 3-16b. ESTIMATION OF u AND u' USING OBF KAUTZ CLASS OF CONTROLLER, $N = 4$ FILTERS USED, NOISE WITH 0.1000 STANDARD DEVIATION.

For better visualization and statistical comparison between the different models used, the Figure (3-17) shows the distribution of estimation error of the u' signal for both OBF Laguerre and OBF Kautz results earlier presented. It is possible to conclude that the distribution of the combined standard uncertainty tends towards a normal (or gaussian) with standard deviation of 1.348 or Kautz and 1.360 for Laguerre identification.

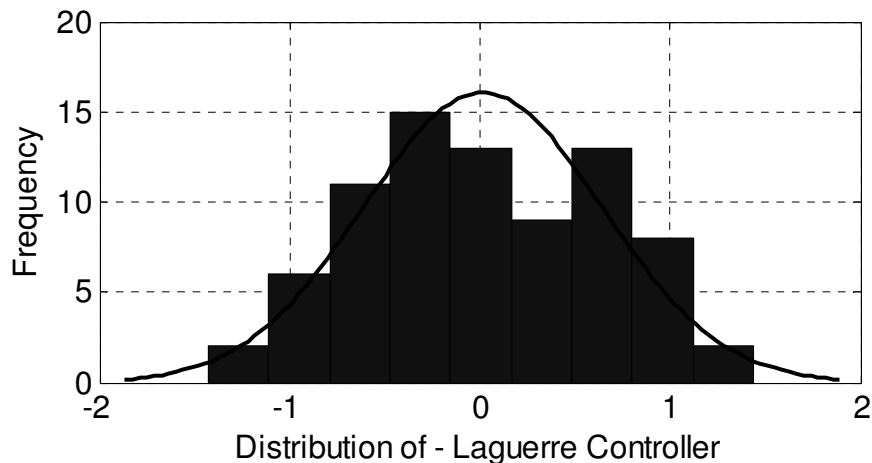
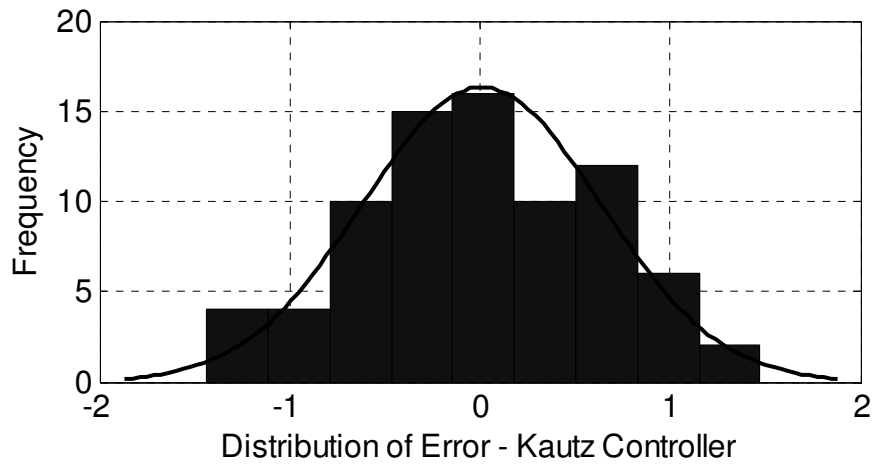

FIGURE 3-17. ERROR HISTOGRAM FROM ESTIMATION OF u USING OBF LAGUERRE AND KAUTZ CLASS OF CONTROLLER; $N=4$.

Not only the identification process results are important to evaluate a model structure in the VRFT technique but also the closed-loop performance can indicate the efficacy of the controller chosen. What can be seen in the following figures and results is that, even though the MSE on identification step is similar between classical VRFT and OBF solutions, the closed-loop performance shows the misbehaviour of the controlled system when facing the PID controller. This example represents the main disadvantage of using a restricted control structure, even when the identification step presents good result, not every dynamic of the reference behaviour is identified and the final system is not capable of reproducing the reference behaviour T . In Figure (3-18) and (3-19) it is presented the closed-loop behavior of the system facing classical and both OBF Laguerre and Kautz functions and its time weighted error between step responses and T .

Even considering no noise input on the step of experiments, both OBF Laguerre and Kautz models were superior in closed-loop response when compared to the PID controller. As expected, the controller could be successfully generalized by the use of multiple orthonormal basis functions. Better comparison and visualization can be obtained from Figures (3-20) and (3-21).

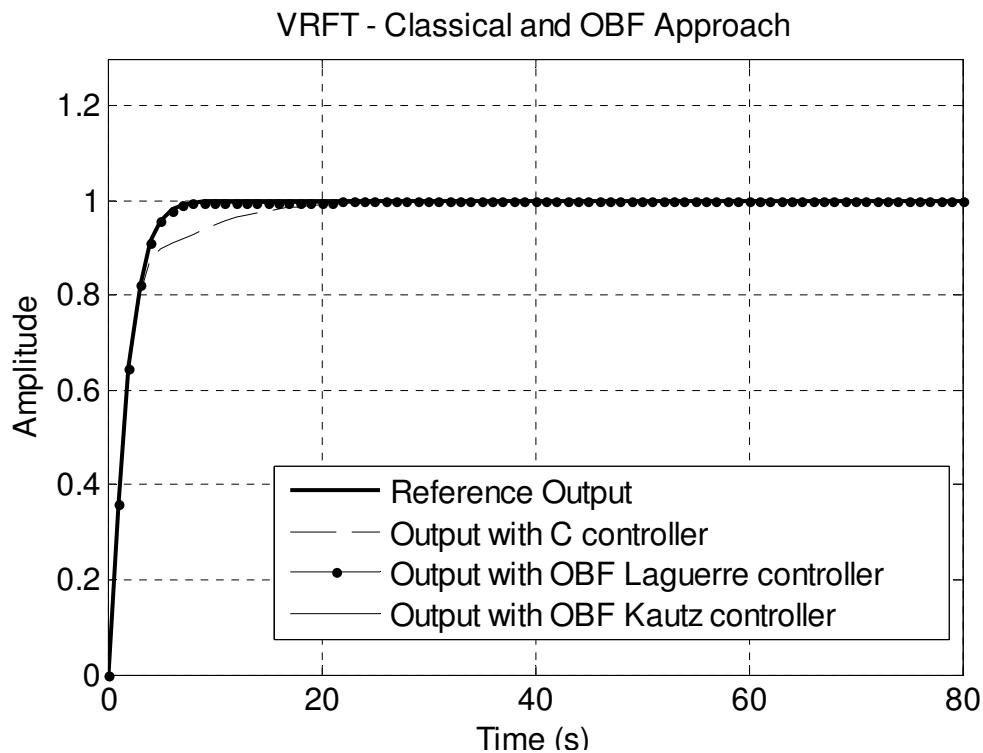

FIGURE 3-18. STEP RESPONSE BY REFERENCE MODEL (DARK SOLID LINE). SYSTEM DESIGNED BY THE CLASSICAL METHOD (DASHED LINE), OBF LAGUERRE (DOTTED LINE) AND OBF KAUTZ (SOLID LINE).

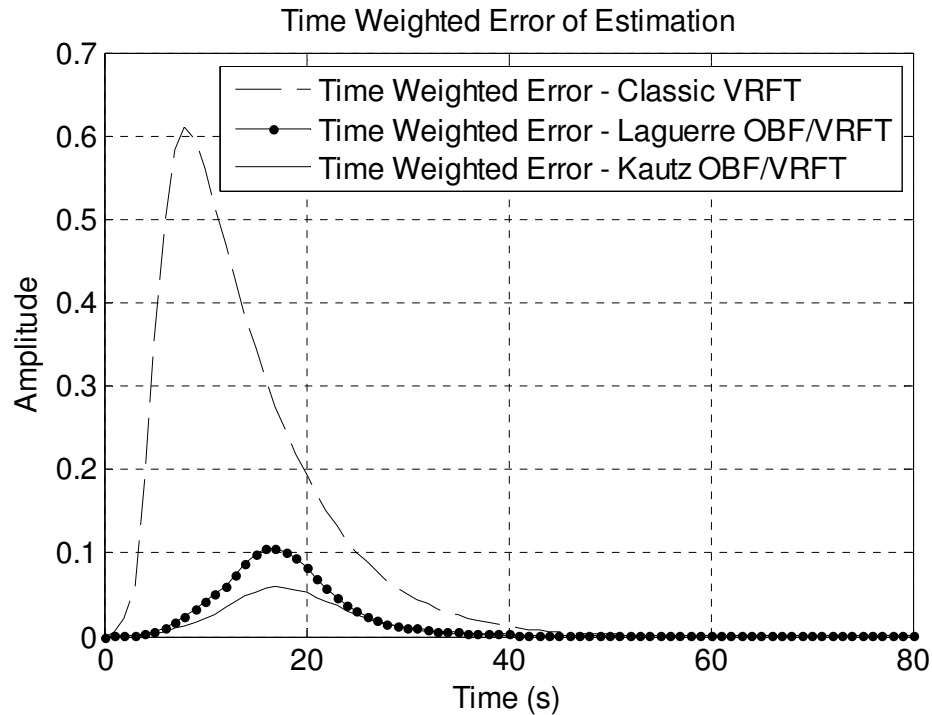

FIGURE 3-19. TIME WEIGHTED ERROR FORM DESIRABLE AND DESIGNED RESPONSE OF: RESPONSE OF SYSTEM DESIGNED BY THE CLASSICAL METHOD (DASHED LINE), OBF LAGUERRE (DOTTED LINE) AND OBF KAUTZ (SOLID LINE).

The step response of the closed-loop system under noise is shown in Figure (3-20) followed by a time-weighted error calculated from the difference between closed-loop step responses and the desired behaviour described by T from Equation (3-40). It is consider six ($n = 6$) Equations for OBF Laguerre and Kautz functions – see Figure (3-21).

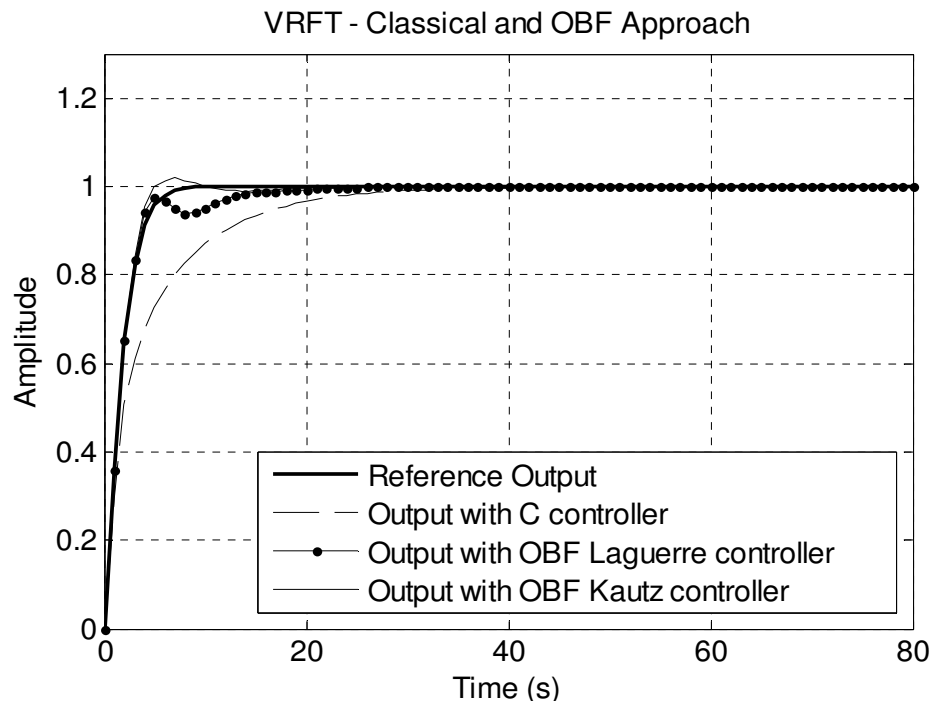

FIGURE 3-20. STEP RESPONSE BY REFERENCE MODEL, SYSTEM DESIGNED BY THE CLASSICAL METHOD, OBF LAGUERRE AND OBF KAUTZ, $N = 6$ FILTERS, NOISE WITH 0.1000 STANDARD DEVIATION.

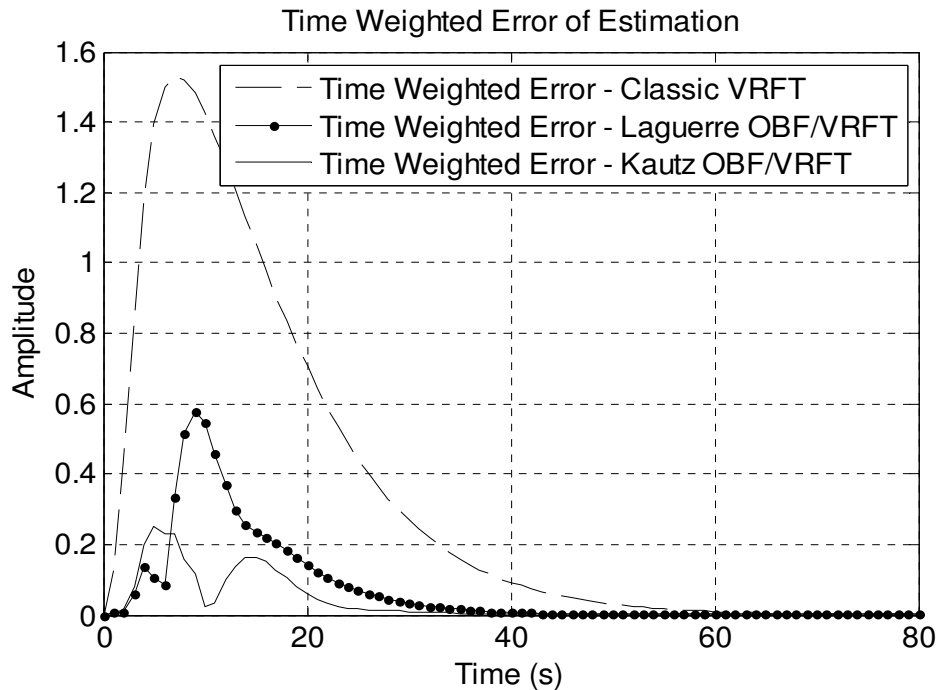

FIGURE 3-21. TIME WEIGHTED FORM STEP RESPONSE BY REFERENCE MODEL. SYSTEM DESIGNED BY THE CLASSICAL METHOD, OBF LAGUERRE AND OBF KAUTZ, $N = 6$ FILTERS, NOISE WITH 0.1000 STANDARD DEVIATION.

Following the results on figures (3-22) and (3-23), with four OBF functions both basis could also identify the controller with low residual energy and consequently smaller ITAE index in closed-loop step response compared to the classical controller structure. Four ($n = 4$) Equations for OBF Laguerre and Kautz functions are used.

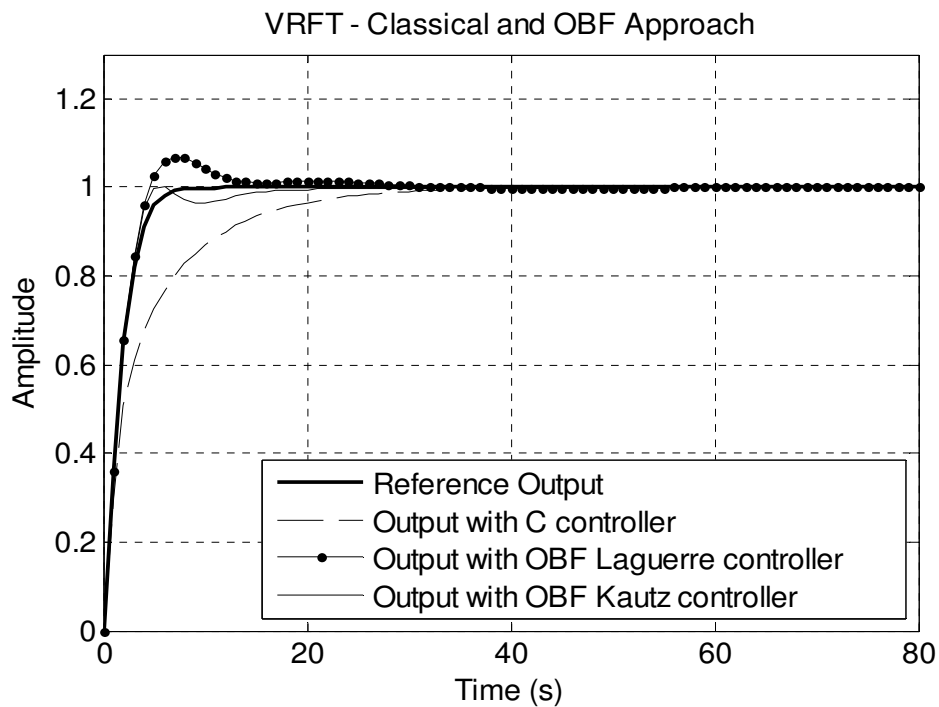

FIGURE 3-22. STEP RESPONSE BY REFERENCE MODEL. SYSTEM DESIGNED BY THE CLASSICAL METHOD, OBF LAGUERRE AND OBF KAUTZ, $N = 4$ FILTERS, NOISE WITH 0.1000 STANDARD DEVIATION.

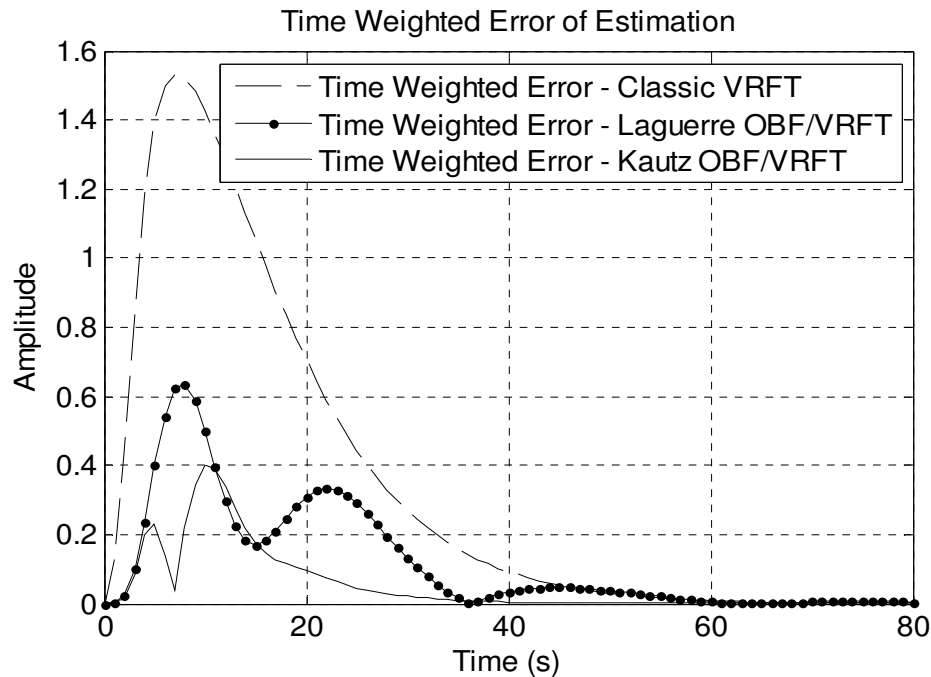

FIGURE 3-23. TIME WEIGHTED FORM STEP RESPONSE BY REFERENCE MODEL. SYSTEM DESIGNED BY THE CLASSICAL METHOD, OBF LAGUERRE AND OBF KAUTZ, $N = 4$ FILTERS, NOISE WITH 0.1000 STANDARD DEVIATION.

As expected, the behaviour between Laguerre and Kautz models are inferior when using four OBF functions, however the results are still at least seven times better on OBF Kautz over classical PID controller – find Table (3-1) and corresponding ITAE values.

For further understanding about the results obtained until this point, Table (3-1) compares the identification results and closed-loop performance of the classical VRFT technique when using OBF Laguerre and Kautz methods to generalize the controller class. At this moment no noise signal is inserted on the initial I/O data and six OBF functions were chosen to represent the controller. The best pole is chosen by a range of valid valued by its lowest residual energy, given by Equation (3-31).

As anticipated, Kautz functions and then Laguerre reduced more than seven times the ITAE error on closed-loop evaluation.

TABLE 3-1. COMPARATIVE RESULTS BETWEEN CLASSICAL VRFT, KAUTZ AND LAGUERRE FUNCTIONS AND QUANTITY OF FUNCTIONS.

Method	Classical VRFT	OBF Laguerre	OBF Kautz
Best pole	-	0.2910	$0.05068 \pm 0.5771i$
Functions	-	6	6
MSE identification step	2.949×10^{-4}	7.138×10^{-7}	1.520×10^{-7}
Residual energy*	-	3.074×10^{-5}	1.229×10^{-7}
ITAE* Closed-loop	8.201	1.384	0.8722

*where every pole is chosen by its lower residual energy (Equation 3-31). ITAE (Integral Time-weighted Absolute Error) value are given by Equation (3-32) (Wang; Cluett, 2000):

$$V = |c(n-1)c(n)| \quad (3-31)$$

$$ITAE = \sum_{k=1}^t k. |u'(k) - \hat{u}'(k)| \quad (3-32)$$

In addition, Table (3-2) compares the identification results and closed-loop performance of the classical VRFT technique when using OBF Laguerre and Kautz methods to generalize the controller class. At this moment there is noise inserted on the initial I/O data and six (then four) OBF functions were chosen to represent the controller. The best pole is also chosen by a range of valid valued by its lowest residual energy, given by Equation (3-31).

As also foreseen, Kautz functions and then Laguerre reduced more than four times for Laguerre and ten times for Kautz the ITAE error on closed-loop evaluation for six functions used.

TABLE 3-2. COMPARATIVE RESULTS BETWEEN CLASSICAL VRFT, KAUTZ AND LAGUERRE FUNCTIONS AND QUANTITY OF FUNCTIONS.

Method	Classical VRFT	OBF Laguerre		OBF Kautz	
Best pole	-	0.1341		$4.100 \times 10^{-3} \pm 0.4900i$	
Functions	-	6	4	6	4
MSE identification step	0.3876	0.3850	0.7870	0.3826	0.3853
Residual energy*	-	3.862×10^{-6}	4.495×10^{-6}	4.749×10^{-7}	1.066×10^{-2}
ITAE* Closed-loop	28.39	5.791	9.266	2.683	4.266

3.5.2 A non-direct approach

In this Section, it will be demonstrated the effectiveness of the non-direct technique presented in this work through an example of simulation. One case will be presented in order to analyze and compare the design of both classical VRFT and OBF-VRFT controllers using the approach proposed in Section 3.4.

At this point, it is considered a particular case when the finite time impulse response with no noise disturbance is available. The VRFT technique is applied considering a fixed class of controllers defined a priori which does not contain the ideal structure. In the sequence, it will be used a series of orthonormal filters with analytically

calculated coefficients based on the impulse response e . The goal is to validate the new way to identify the controller using the VRFT technique in one study case where the classical procedure presents problems.

Thus, let's consider G plant from Figure (3-1) defined as:

$$G(q) = \frac{0.2000(q - 0.7000)}{(q - 0.1000)(q - 0.5000)} \quad (3-33)$$

It is necessary to define the desired behavior of the system T and, in the case of the classical design of the VRFT, a class of controllers C^* .

$$T(q) = \frac{0.1600q}{(q - 0.6000)^2} \quad (3-34)$$

and the control class:

$$C(q, \theta) = \frac{\theta_1 q^2 + \theta_2 q + \theta_3}{q(q - 1)} \quad (3-35)$$

Given the controller class chosen by the Equation (3-35), the computed parameter for the controller were:

$$C(q) = \frac{0.7780q^2 - 0.3245q - 0.1535}{q(q - 1)} \quad (3-36)$$

After tuning the controller given the classical VRFT approach, the second step of this simulation section regards the results of the OBF method.

In this way, through the use of the OBF of Laguerre and Kautz, it is estimated the transfer function between u and e in order to obtain the controller C' and then C . To this end, eight functions were used with pole 0.1490 for Laguerre OBF and $0.00055 + 0.005j$ for Kautz filters. The number of functions and the pole value were defined as tests of the proposed system. It is not objective this Chapter address a new or an existent way to predetermine those parameters, however, as highlighted in Chapter 2, several works in the field deal with the optimal estimation of p . Among them (OLIVEIRA SILVA, 1995).

As discussed in Section 3.4, as the OBF identifies the controller based on the e impulse response, Figure (3-25) shows real and estimated e signals using Kautz and Laguerre OBF models.

For Laguerre OBF, the maximum error of estimate (L^∞) was 7.32×10^{-5} , with residual energy 5.1231×10^{-7} , given by $v = |c(n - 1)c(n)|$ (WANG; CLUETT, 2000). Being the coefficients obtained as:

$$\{c_i\}_{i=1}^8 = \{0.9780 \quad -1.7668 \quad 0.9909 \quad -0.2579 \quad 6.340 \times 10^{-2} \\ -1.040 \times 10^{-2} \quad 2.800 \times 10^{-3} \quad 2.000 \times 10^{-4}\} \tag{3-37}$$

By using Kautz OBF filters, the maximum error of estimate (L^∞) was 3.9×10^{-4} , with residual energy 3.771×10^{-6} given by $v = |c(n-1)c(n)|$ (WANG; CLUETT, 2000). Being the coefficients obtained as:

$$\{c_i\}_{i=1}^8 = \{1.2490 \quad -1.8257 \quad 0.4866 \quad 0.06440 \\ 0.1510 \quad 5.800 \times 10^{-3} \quad 2.700 \times 10^{-3} \quad 1.400 \times 10^{-3}\} \tag{3-38}$$

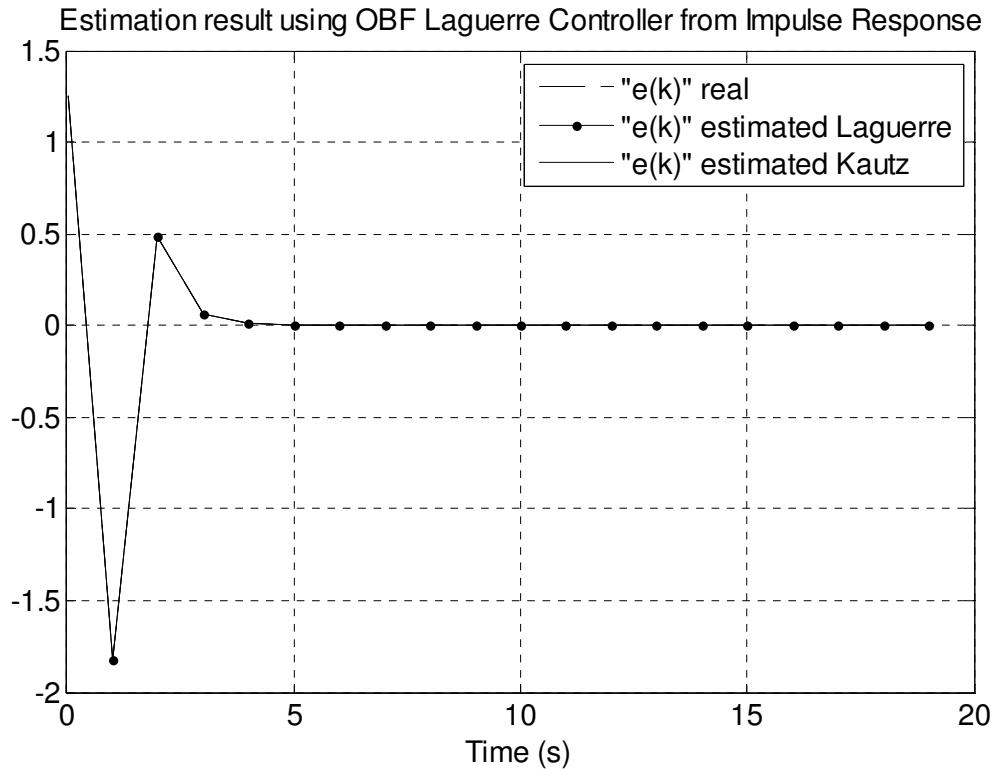

FIGURE 3-24. REAL AND ESTIMATED e DATA VIA OBF LAGUERRE AND KAUTZ.

Furthermore, the outputs of the closed-loop system with controller structure estimated by signal e via OBF and controller given by the traditional method (with fixed structure) are given by Figure (3-25) and (3-26).

It is possible to observe that the data-driven controller obtained by the virtual reference method (VRFT) with structure based on orthonormal basis functions can adapt to the ideal controller with great efficiency as noted in Figure (3-26).

The error between the step responses in closed-loop system designed via VRFT classical and OBF in relation to output references are in Figure (3-26). It is important to note that in this Figure the error between the reference model T obtained by VRFT method with OBF structure controller is weighted by the time and a constant increasing

absolute value observed in both Kautz and Laguerre approaches are result of a steady state error on the closed-loop performance.

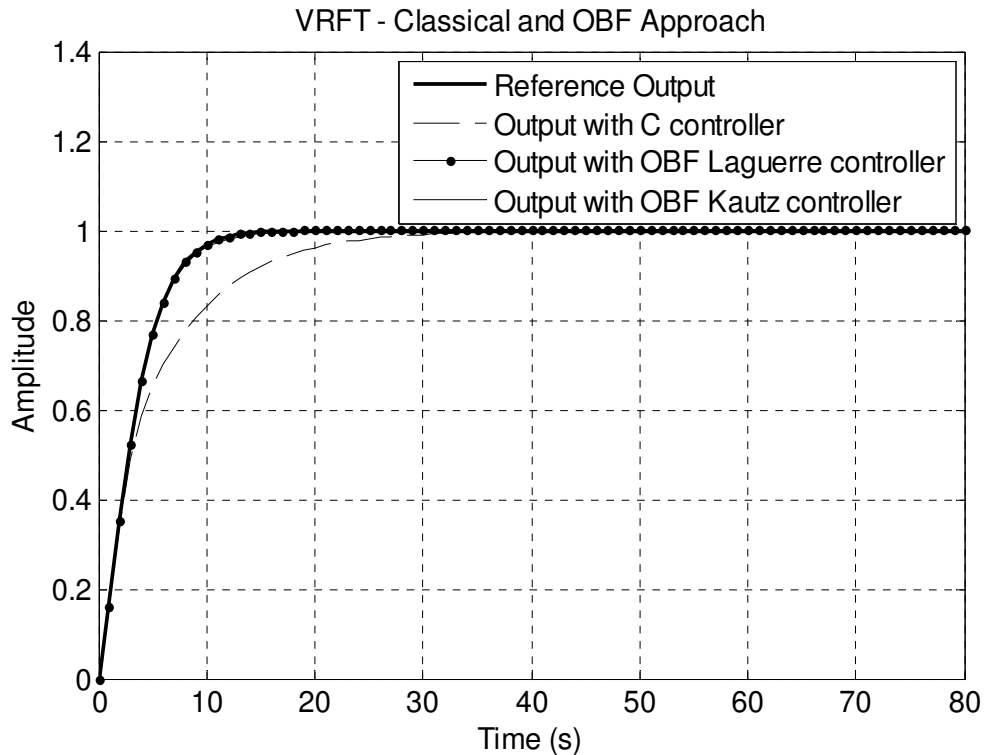

FIGURE 3-25. CLOSED-LOOP SYSTEM WITH CONTROLLER GIVEN BY CLASSICAL AND OBF VRFT METHODS AND THE REFERENCE OUTPUT.

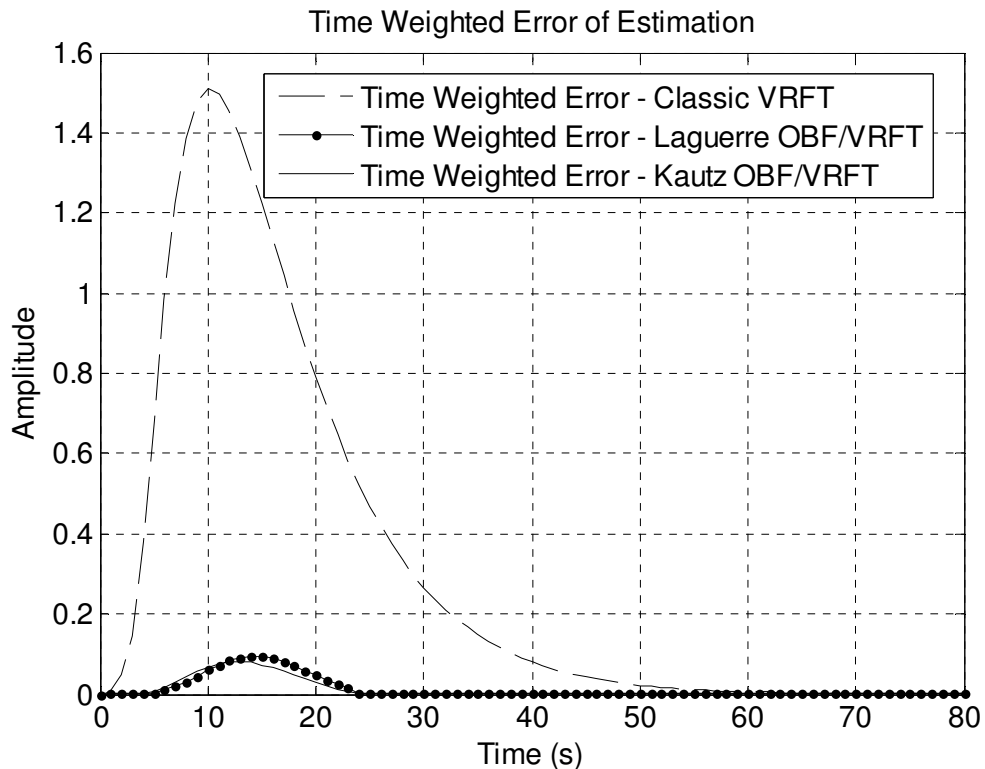

FIGURE 3-26. THE TIME WEIGHTED ERROR DEFINED BY CLASSICAL AND OBF CONTROLLER.

Comparing Laguerre and Kautz OBF results, both filters could solve the problem with great accuracy, even considering only seven filters. Compared to classical approach,

the results were better and the proposed objective of the solution was achieved with great success. However, the non-direct solution using orthonormal basis functions have some issues to be solved, for instance: it does not provide features to deal with noise input on y usually present in the step of experiments.

3.6 Conclusion

The objective proposed in this Chapter is to present a technique that generalize the structure of the given controller via virtual reference method contributing to the development and applicability of the VRFT technique and identification method based on data, as well other papers and studies that may surge in these areas.

In this context, two main OBF solutions were studied and are called as *non-direct* and *direct* approaches. The first one is recommended when an impulse response of the plant is available and the system is simple enough to be identifying using an analytical and modest solution. When the system doesn't provide an impulse response from the plant or it has any kind of input noise, the non-direct solution cannot solve the problem. For such applications, a second methodology is developed. In this case, the controller is identified directly from the input (reference signal) and output u' . Using this procedure, more accurate results and closed-loop performance were obtained.

Considering results and assumptions until this point, the controller parameterization through the method of orthonormal basis functions proved to be efficient and served its purpose for linear systems. The applicability of such method is great since its only condition is the plant and reference responses with finite memory, which is the majority case when it comes about the VRFT technique.

4 THE VIRTUAL REFERENCE FEEDBACK TUNING USING VOLTERRA-ORTHONORMAL BASIS FUNCTIONS FOR NONLINEAR SYSTEMS

The Virtual Reference Feedback Tuning (VRFT) design is a non-iterative method that intends to identify a controller from one set of data collected from plant. Although it is a good alternative for controller design, it searches the controller parameters in a pre-defined structure. It means the class of controller must be assigned precisely, otherwise the feedback system may not respond as the selected reference model. This Chapter approaches this issue by adapting a control structure using Volterra-Orthonormal basis functions in order to improve the VRFT theory and applicability on nonlinear systems. Simulation results are presented to illustrate the effectiveness compared between conventional VRFT and Volterra-OBF VRFT.

4.1 Introduction

The Virtual Reference Feedback Tuning (VRFT) is a data-driven method for direct design of controllers based on input and output data signals measured from a plant to be controlled. As data-based techniques resume the performance criteria into a discrete time transfer function, it is said that the VRFT technique recasts the problem of control design into a system identification problem, where a controlled system closed-loop behavior is compared to a reference transfer function (CAMPI et al., 2002, 2003; KANSHA et al., 2008).

During the identification step, it is assumed that the controller class chosen is such that the desired response is feasible. To minimize the dependency of the chosen controller class, there are many papers focusing on using PID control structure but improving identification procedure by many different approaches. One example is the paper presented by (YANG et al., 2012) which extended and improved results in the application of adaptive VRFT by increasing the reference model order and by upgrading its parameters at each sampling instant. More recently, (RODRIGUES et al., 2014) presented an algorithm to identify the best reference model structure (given some control performance criteria) in order to optimize a PID or PI controller response.

When it comes about nonlinear systems, (CAMPI; SAVARESI, 2006) generalized the VRFT technique for both linear and nonlinear systems. After 2008, many papers

presented new tools to improve results of VRFT methodology on nonlinear system, some of them are (CUNHA; BAZANELLA, 2012; FORMENTIN et al., 2013) where the first one introduces an alternative to enhance VRFT controller parameterization by improving nonlinear compensation and the second one manipulates the input signal such that the control cost is reduced.

As from now, many papers addressed efforts to improve the VRFT performance on linear and nonlinear systems by manipulating input signals, compensating static nonlinearities or enhanced VRFT design introducing an adaptive methodology (YANG et al., 2012). However, one of the main challenges of the VRFT technique is to choose a control class that contains the ideal structure so that the closed-loop system behaves as a reference signal (CAMPI et al., 2002; CAMPI; SAVARESI, 2006; NEUHAUS, 2012). As the VRFT technique involves a system identification procedure, it is not restricted to PID controllers and it is possible to adapt a nonlinear identification method that can describe the controller behavior and its structure with more accuracy than the traditional PID approach without pledge of feasibility in real controlled systems.

Beyond many models for nonlinear system available (CAMPELLO et al., 2007; SINHA, 1989; AGUIRRE, 2007), the Volterra models have being successfully applied in identification of dynamic nonlinear systems due its linear-in-parameters structure. However, it usually needs too many parameters to represent each kernel (SJÖBERG et al., 1995; NELLES, 2001; DOYLE et al., 2002) reducing its applicability and accuracy. In order to improve Volterra models, it is possible to reduce the number of parameters by using it combined with orthonormal basis functions (OBF), where each kernel is determined as an expansion of different OBF with the same or different number of functions (SCHETZEN, 1980; DOYLE et al., 2002; SONI, 2006).

After all, as most real systems are nonlinear in nature, it is known and expected that nonlinear models often present better identification results for real systems (AGUIRRE, 2007) than linear models. In order to decrease the sensitivity of the VRFT in control structure selection and improve applicability of this technique on nonlinear systems this Chapter intends to enhance the virtual reference technique by applying the Volterra-OBF on the controller structure models.

The outline of this Chapter is as follows: Section 4.2 describes the VRFT technique for nonlinear systems and its proprieties. In Section 4.3, it is proposed a control structure formed by Volterra-OBF using the VRFT approach. In the following Section, it is

shown some simulation examples of the proposed strategy, and finally, in Section 4.5, the paper is concluded.

4.2 The Virtual Reference Feedback Tuning Technique for nonlinear systems

The Virtual Reference Feedback Tuning (CAMPI et al., 2002, 2003) is a non-iterative method that consists in finding parameters of the controller in order to get a feedback model that behaves like a reference model. In this Section, it is discussed the VRFT design for nonlinear systems which was first generalized by (CAMPI; SAVARESI, 2006).

The VRFT technique can be illustrated by Figure (4-1) and (4-2) where the reference model T describes the desired performance of the system with nonlinear plant G given a controller C . In the same Figure, u e y are respectively the input and output values with a disturbance signal v and \bar{r} the reference output obtained from the inverse of the reference T and y .

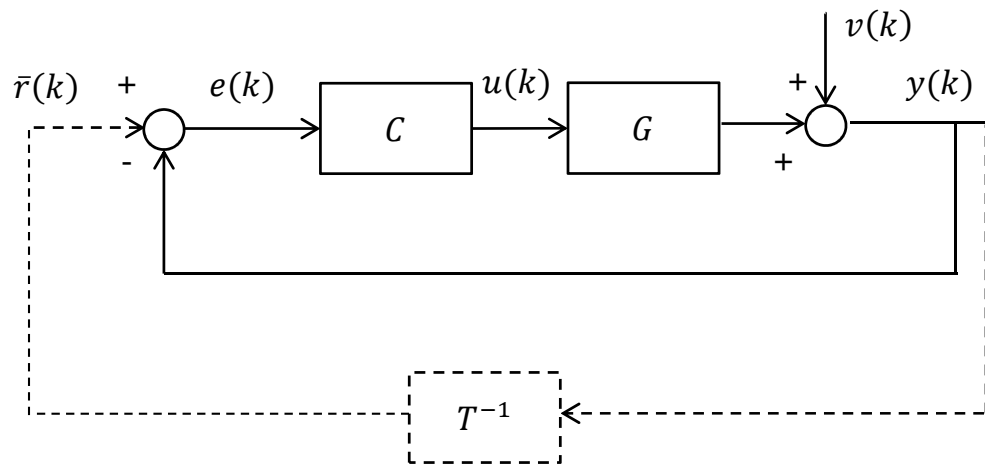

FIGURE 4-1. UNITARY FEEDBACK CONTROL SYSTEM, BEING T THE DESIRED DYNAMICS.

Therefore, from Figure (4-1), C , G are assumed nonlinear systems, such as:

$$\begin{aligned} C\{e\} &: e(k) \rightarrow u(k), \\ G\{u\} &: u(k) \rightarrow y(k), \end{aligned} \tag{4-1}$$

and T is a linear system defined in terms of a rational transfer function on the shift operator q .

The main idea behind the VRFT technique is to minimize a cost function given by Equation (4-2) without identifying G . To do so, \bar{r} it is not a real reference signal but it is only

calculated to generate the simulated output signal $e(k) = \bar{r}(k) - y(k)$ without the controller action.

Doing so, $J(\theta)$ is given by:

$$\min_{\theta} J(\theta)$$

$$J(\theta) = \frac{1}{N} \sum_{k=1}^N [u(k) - C(q, \theta)e(k)]^2. \quad (4-2)$$

After all, the characteristic of the VRFT methodology is to turn the feedback controller design C with parameters θ into a system identification procedure, so that the closed-loop system behaves as close as possible to the pre-specified model, T .

In the following sections, a generalized control structure using orthonormal basis functions for nonlinear systems is presented to achieve better identification of u and consequent closed-loop feedback response.

4.3 Control Structure on VRFT using Volterra-OBF

Also called as a one-shot method, the VRFT is a not iterative technique that intends to turn the controller design problem into a system identification procedure. From Figure (4-1), the identification step of the VRFT aims to reduce an error from a real and estimated u , being \hat{u} the estimated data from the modelled dynamics and an input e , where:

$$e(k) = \bar{r}(k) - y(k). \quad (4-3)$$

being \bar{r} given by $\bar{r}(k) = T^{-1}(q)y(k)$ where y is the real output of the plant given in a set of I/O data and T a reference model.

Thus, it is assumed that the initial set of data (input and output) is formed by the response y of the nonlinear plant G to u .

At this point, by using the VRFT method, it is possible to obtain a set of input-output data for the system identification procedure which results in a controller whose system behaves as T . As discussed in Section 4.2, when it comes about nonlinear system identification, the OBF-based linear models can relate the input u to the orthonormal states l from Equation (4-7) followed by a nonlinear static mapping called \mathcal{H} from Equation (2-15) on Chapter 2 relating these states and the output \hat{y} . Such implementation

is particularly interesting for the problem of the VRFT because, among many reasons, the controller structure is linear in parameters.

So, assuming the data set $Z = \{u(k), y(k)\}_{k=1}^N$ measured from G and $Z' = \{e(k), u(k)\}_{k=1}^N$ is known. The controller synthesis is reduced to find θ that minimizes the following objective function.

$$\min_{\theta} J(\theta)$$

$$J(\theta) = \frac{1}{N} \sum_{k=1}^N [u(k) - C\{e\}]^2 \quad (4-4)$$

To improve steady-state error properties for step like reference signals it is desirable to set at least one pole equal one. To assure the existence of this pole, it is necessary to update the output of the Volterra-OBF controller u to u' as described in the Figure (4-2) and Equation (4-5).

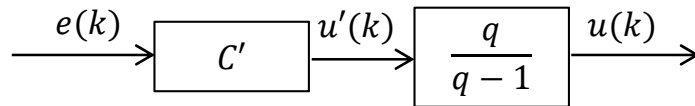

FIGURE 4-2. FILTERED u' CONTROLLER OUTPUT TO ASSURE OBF TRANSFER FUNCTION WITH ONE POLE EQUAL ONE.

$$u(k) = \frac{q}{(q-1)} u'(k). \quad (4-5)$$

and the nonlinear operator $C'\{e\}$ has fading memory and can be approximated by Volterra models.

$$C'\{e\}: e(k) \rightarrow u'(k) \quad (4-6)$$

So, given the theoretical explanation presented in Chapter 2, the estimated filtered controller output u' becomes:

$$\hat{u}'(k) = c_0 + \sum_{i_1=1}^{n_1} c_{i_1} l_{i_1}(k) + \sum_{i_1=1}^{n_2} \sum_{i_2=1}^{i_1} c_{i_1, i_2} l_{i_1}(k) l_{i_2}(k), \quad (4-7)$$

being $l_i(k) = \sum_{\tau=0}^{\infty} \phi_i(\tau) e(k-\tau)$.

Therefore, assuming available the data set Z , the system identification problem for controller synthesis can be rewritten as:

$$\min_{\theta} J(\theta)$$

$$J(\theta) = \frac{1}{N} \sum_{k=1}^N \{u'(k) - \hat{u}'(k)\} \quad (4-8)$$

After all set, the input and output data can be approximated by Volterra-OBF models, such as described in Equations (4-6) if the system meets the following requirements (Oliveira et al., 2012):

- Given the Volterra-OBF model realization for this problem $u'(k) = \mathcal{G}(\{e(\tau)\}_{\tau=-\infty}^k)$, \mathcal{G} is a causal, continuous, time-invariant with fading memory non-generic nonlinear operator;
- The input, in this case e , is upper and lower bounded.

4.4 Simulation Example

In this Section, it will be presented two case studies in order to validate the controller structure generalization in VRFT technique and compare identification and closed-loop performances in a nonlinear system when the classical procedure presents problems.

4.4.1 General Case Study

First, both classical and OBF-VRFT controllers are compared regarding identification performance. The goal is to obtain an u' output as close as possible to the e signal, and minimize the error between the controlled system and the required performance (reference transfer function).

Secondly, the closed-loop performance is evaluated and a further comparison is made between Volterra-Laguerre and Volterra-Kautz functions.

Thus, consider a nonlinear Wiener type plant G which is causal, time-invariant and fading memory. It is assumed that the initial set of data (input and output) is formed by the response y of the plant G to u , where $u \in \mathcal{N}_{iid}(0, \sigma^2)$ and $\sigma = 1$ and a noise signal v . From Figure (4-1) it can be said that:

$$\begin{aligned} z(k) &= G_0(q)u(k); \\ y(k) &= \zeta(z(k)) + v(k). \end{aligned} \tag{4-9}$$

Where $v(k)$ is the disturbance signal and:

$$G_0(q) = \frac{0.2000(q - 0.7000)}{(q - 0.1000)(q - 0.5000)}; \tag{4-10}$$

$$\zeta(z(k)) = 1.5000z(k) + 0.2000z^3(k).$$

Finally, it is necessary to define the desired behavior of the system T and, in the case of the classical design of the VRFT, a class of controllers \mathcal{C} . In this case the class chosen does not contain the structure of the ideal controller.

Reference Model:

$$T(q) = \frac{0.16q}{(q - 0.6)^2}. \quad (4-11)$$

Control Structure:

$$C(q, \theta) = \frac{\theta_1 q^2 + \theta_2 q + \theta_3}{q(q - 1)}. \quad (4-12)$$

As far as the disturbance signal is analyzed, two situations will be presented. The first one is a noise free case and the second one considers v as a random signal composed by a normal distributed signal u where $u \in \mathcal{N}_{iid}(0, \sigma^2)$ and $\sigma = 0.1000$ filtered by a first order transfer function given by H :

$$H = \frac{0.7}{q - 0.3}. \quad (4-13)$$

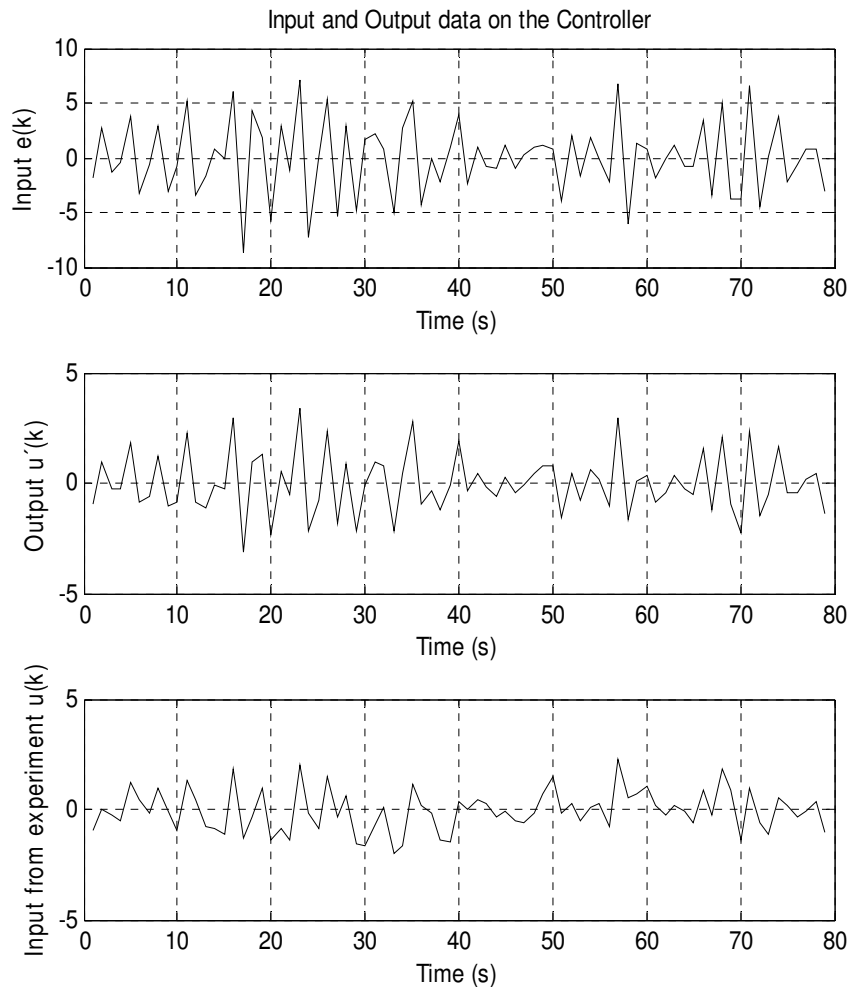

FIGURE 4-3. FIRST CHART: INPUT OF THE CONTROLLER - e ; SECOND CHART: OUTPUT u' ; THIRD CHART: REAL INPUT FROM EXPERIMENTS u .

The Figure (4-3) shows the input and output signals u, u' and e for the closed-loop system in study for a noise free case. Every signal proposed in the system is capable of being implemented in a real situation. It is worth remembering that the reference signal e doesn't exist in reality and it is only used for mathematical purposes.

Given the controller class chosen by the Equation (4-12), the computed parameter for the PID controller were:

$$\theta = [0.5006 \quad 0.2092 \quad 9.51 \times 10^{-2}]^T$$

$$C(q) = \frac{0.5006 q^2 + 0.2092 q + 9.51 \times 10^{-2}}{q(q-1)} \quad (4-14)$$

In Figure (4-4) is presented the results using the classical PID controller while Figure (4-5) shows the identification result for classical and (N)OBF approach regarding Volterra-Laguerre model. Both consider a noise free case.

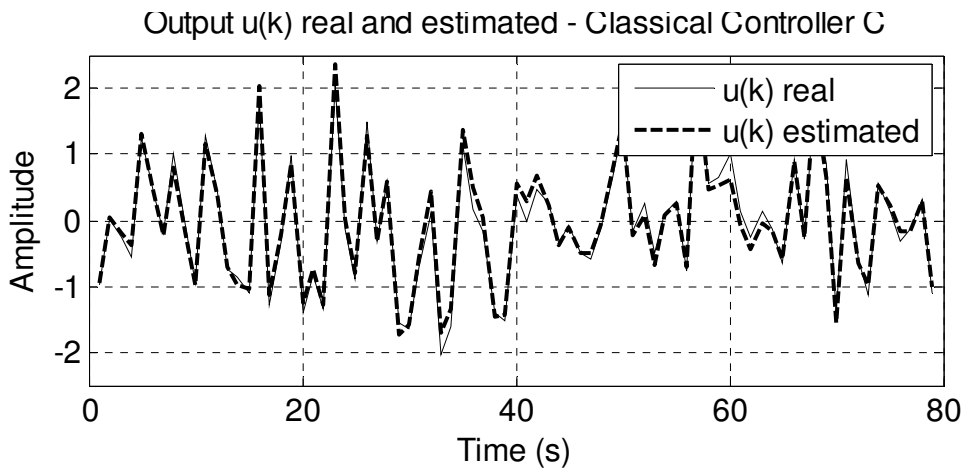

FIGURE 4-4. ESTIMATION RESULT FROM u REAL AND ESTIMATED USING CLASSICAL VRFT APPROACH WITH PRE-DEFINED CONTROL STRUCTURE.

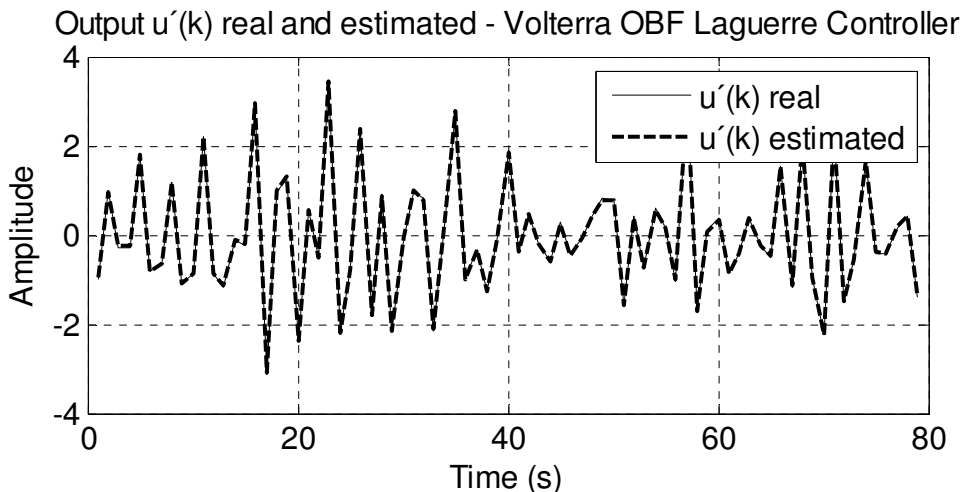

FIGURE 4-5a. ESTIMATION OF u' AND u USING VOLTERRA-LAGUERRE CLASS OF CONTROLLER, $n_1, n_2 = 4$ FILTERS USED.

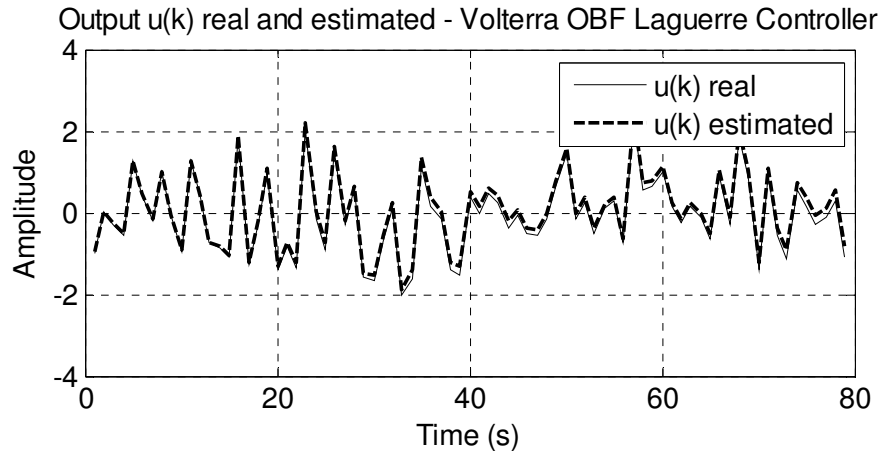

FIGURE 4-5b. ESTIMATION OF u' AND u USING VOLTERRA-LAGUERRE CLASS OF CONTROLLER, $n_1, n_2 = 4$ FILTERS USED.

Lastly, Figure (4-6) gives the results obtained using Volterra-Kautz model. The main idea behind those charts is to compare identification performance in using VRFT-OBF approach and classical VRFT when controller class does not contain the ideal one.

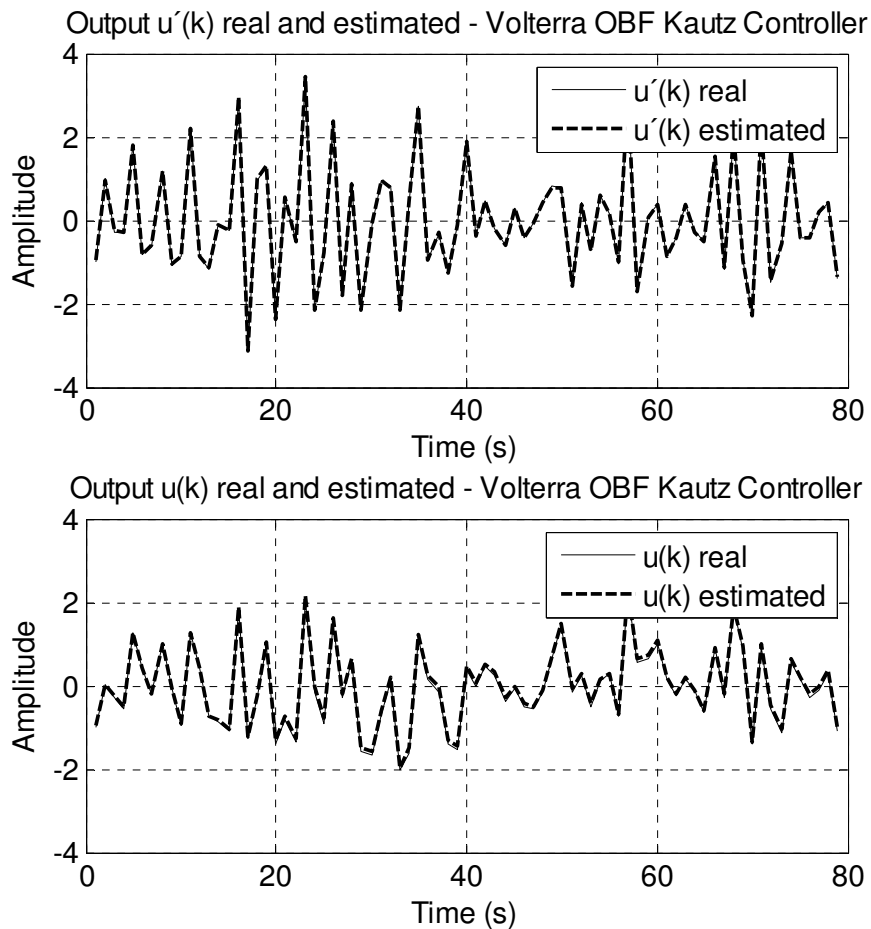

FIGURE 4-6. ESTIMATION OF u' AND u USING VOLTERRA-KAUTZ CLASS OF CONTROLLER, $n_1, n_2 = 4$ FILTERS USED.

For better visualization and statistical comparison between the different models used, the Figure (4-7) shows the distribution of estimation error of the u' signal for both Volterra-OBF Laguerre and Volterra-OBF Kautz results earlier presented. It is possible to conclude that the distribution of the combined standard uncertainty tends towards a normal (or gaussian) with standard deviation of 0.0586 for Kautz and 0.0689 for Laguerre identification.

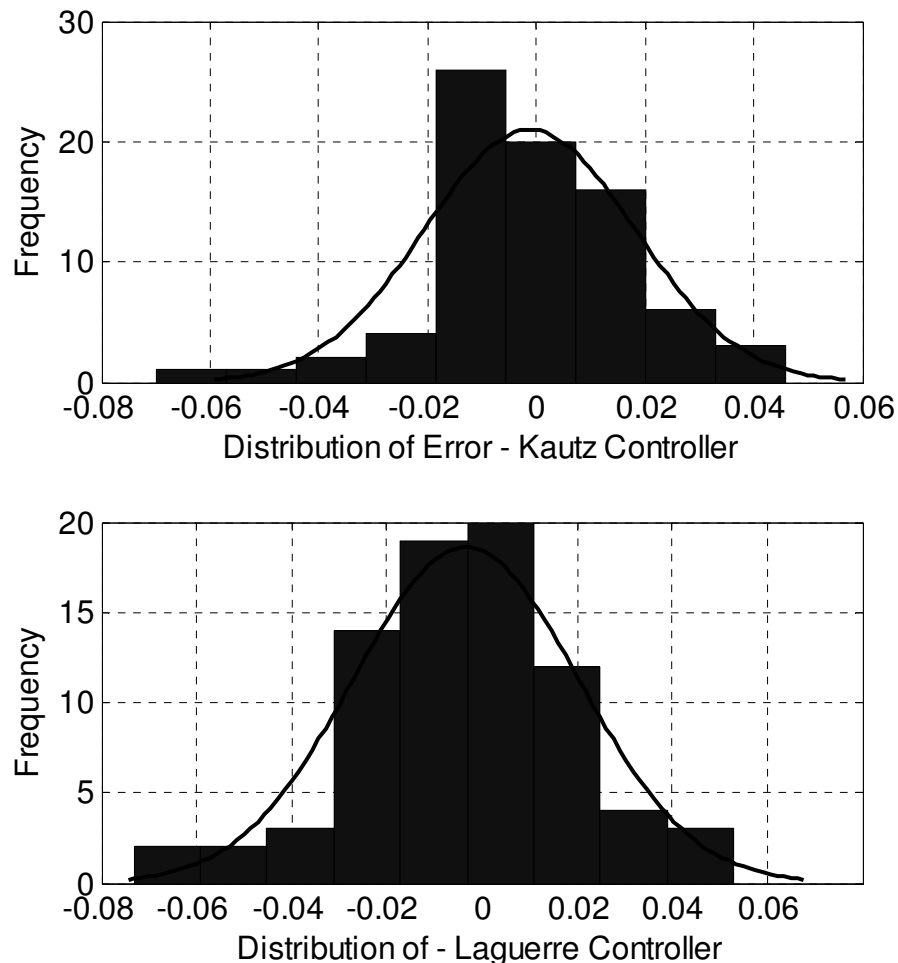

FIGURE 4-7. ERROR HISTOGRAM FROM ESTIMATION OF u USING OBF LAGUERRE AND KAUTZ CLASS OF CONTROLLER

The results were obtained from four functions, the pole p was defined after several test in a range of p and it was selected by its lower MSE value during identification of u' . For further understanding about the results obtained until this point, Table (4-1) to (4-3) compare the identification and closed-loop performances of the classical VRFT technique when using Volterra-OBF Laguerre and Kautz methods to generalize the controller class.

Moreover, still in Tables (4-1) and (4-2) it can be observed the same experiment, but when a random noise is added in the output signal. The noise v is a

random signal with normal distribution $\mathcal{N}_{iid}(0, \sigma^2)$ and $\sigma = 0.1000$, filtered by H according to Equation (4-14). At this time both OBF structures are built with $n = \max\{n_1, n_2\} = 4$ number of functions and both Laguerre and Kautz p constant is chosen based on the best MSE result on u' OBF identification.

TABLE 4-1. RESULTS OF VOLTERRA-LAGUERRE AND VOLTERRA-KAUTZ METHODS FOR EACH VALUE OF NOISE DISTURBANCE.

Method	Volterra-Laguerre		Volterra-Kautz	
$\mathcal{N}_{iid}(0, \sigma^2)$	0.000	0.1000	0.0000	0.1000
Best pole	0.2010	0.1500	$0.3010 \pm 0.7010i$	$0.1010 \pm 0.4010i$
MSE	$5.666.1 \times 10^{-4}$	0.0556	3.709×10^{-4}	0.0546

TABLE 4-2. RESULTS USING CLASSICAL VRFT TECHNIQUE AND QUANTITY OF NOISE DISTURBANCE v .

Method	Classical VRFT	
$\mathcal{N}_{iid}(0, \sigma^2)$	0.000	0.1000
MSE	0.022	0.1647
Coefficients $[\theta_1, \theta_2, \theta_3]^T$	$\begin{bmatrix} 0.5006 \\ 0.2092 \\ 9.51 \times 10^{-2} \end{bmatrix}$	$\begin{bmatrix} 0.4111 \\ 0.1000 \\ 0.01139 \end{bmatrix}$

The following charts shows the closed-loop performance of the system for both Volterra-Laguerre and Volterra-Kautz (Figure 4-8) comparing to the desired performance given by the transfer function T and the result obtained with the classical VRFT procedure when the system is noise free.

From Figure (4-8), it is remarkable the misbehaviour of the closed-loop system in relation to the desired performance when using C from Equation (4-14). Figure (4-9) shows a time weighted absolute error between desired and real closed-loop performance when applying the new Volterra-OBF controller using Laguerre and then Kautz functions. In Figures (4-8) and (4-9), only the study of noise free system is presented.

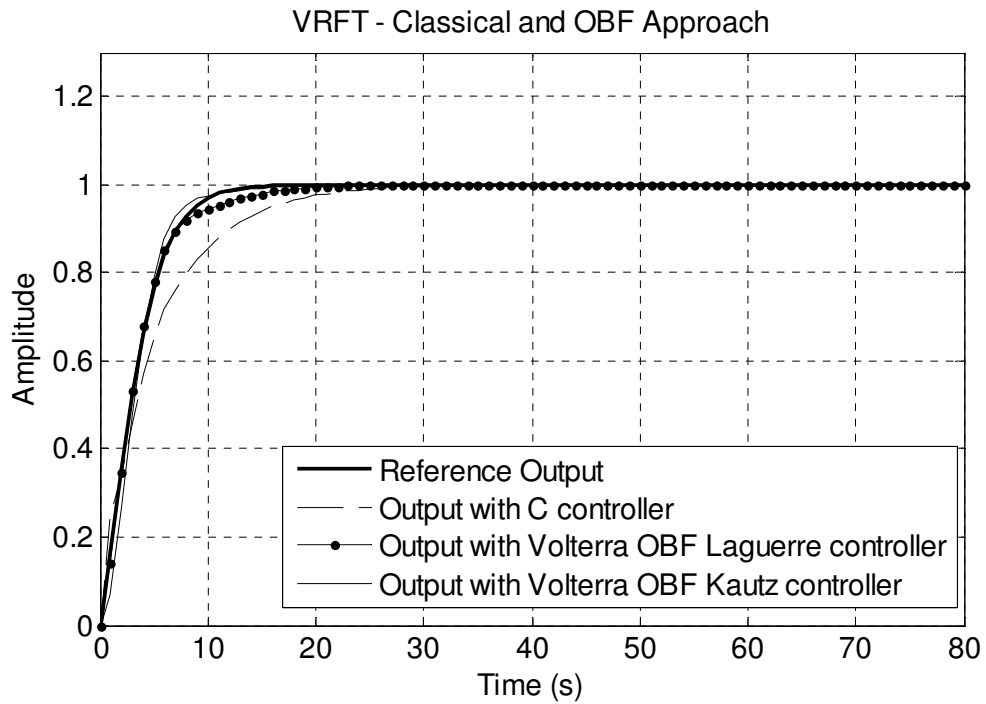

FIGURE 4-8. CLOSED-LOOP RESULTS FOR CLASSICAL VRFT TECHNIQUE, VOLTERRA-LAGUERRE AND VOLTERRA-KAUTZ CONTROLLERS.

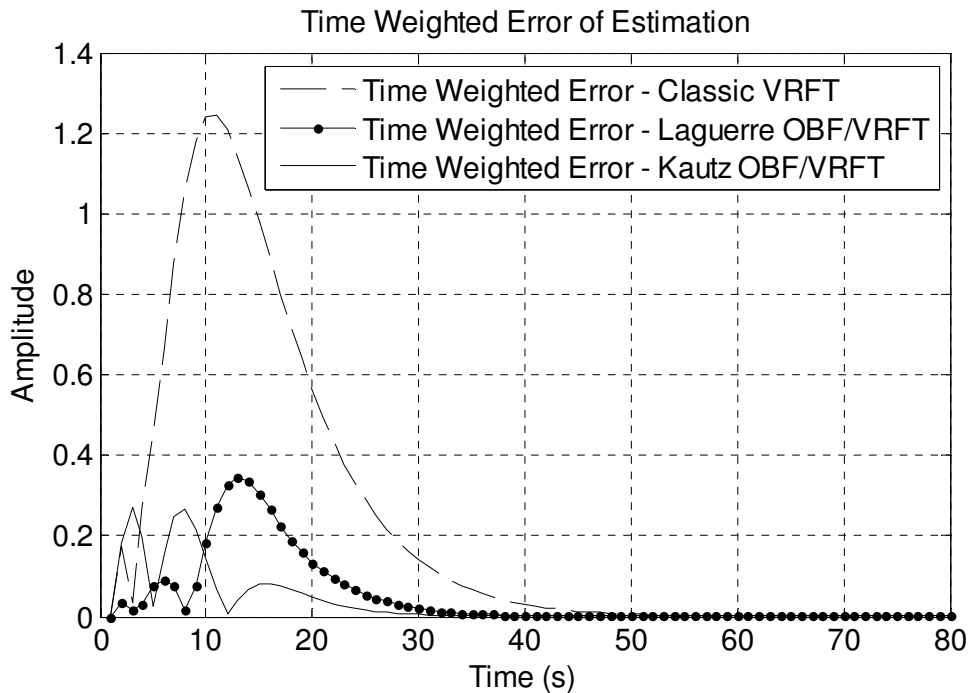

FIGURE 4-9. A TIME WEIGHTED ABSOLUTE ERROR BETWEEN REFERENCE AND REAL CLOSED-LOOP OUTPUT y WHEN THE SYSTEM IS NOISE FREE.

When there is an increase in noise level introduced by the v signal, the performance regarding the OBF functions changes and a comparison between Laguerre and Kautz functions becomes even more important. Therefore, the

following results regards the introducing of a normal distributed noise v where $v \in \mathcal{N}_{iid}(0, \sigma^2)$ and $\sigma = 0.1$.

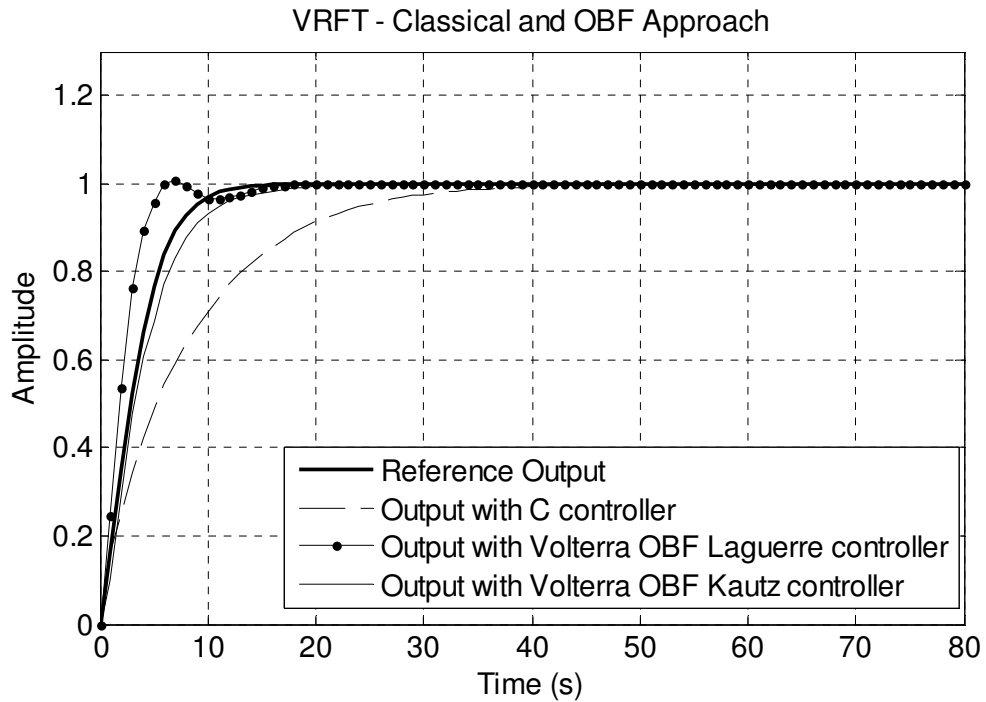

FIGURE 4-10. RESULT OF CLOSED-LOOP STEP FROM CLASSICAL IDENTIFICATION, VOLTERRA-LAGUERRE AND VOLTERRA-KAUTZ CONTROLLERS; NOISE WITH STANDARD DEVIATION 0.1.

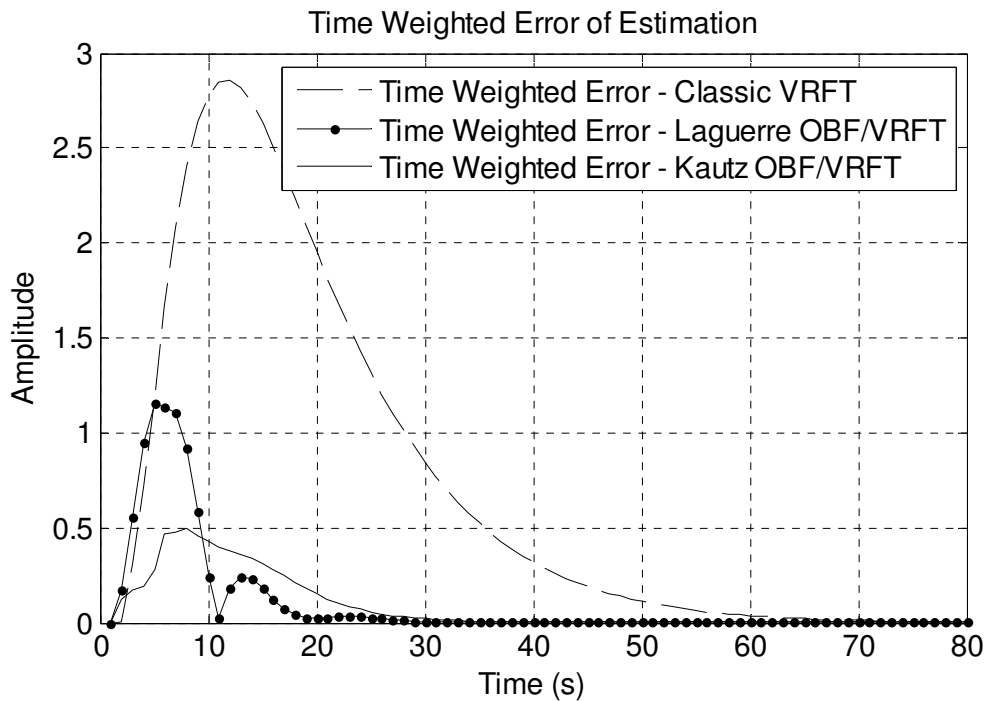

FIGURE 4-11. TIME WEIGHTED ABSOLUTE ERROR BETWEEN REFERENCE AND REAL CLOSED-LOOP OUTPUT WHEN USING VOLTERRA-OBF CONTROLLERS; NOISE WITH STANDARD DEVIATION 0.1.

The closed-loop behavior of the system shown in Figure (4-11) presents the result with three different controller structures: OBF (Volterra-Laguerre, Volterra-Kautz) and classical structure as show in Equation (4-14). The ITAE for VRFT controller structure constructed using Volterra-Laguerre and Volterra-Kautz functions can be seen in the Figure (4-10).

When the controller structure is constructed using Volterra-Kautz functions - figures (4-11 and 4-12) - the results regarding MSE and ITAE indexes are expressively better than shown for Volterra-Laguerre in the same figures, details can be found in Table (4-3).

Table (4-3) summarizes the responses between Volterra-Laguerre and Volterra-Kautz functions as well their behavior with (and without) noise levels. Every ITAE result and MSE value is calculated based on the reference transfer function T and the output of the closed-loop system with the three controllers, respectively.

TABLE 4-3. SUMMARY OF RESULTS OF VOLTERRA-KAUTZ, VOLTERRA-LAGUERRE FUNCTIONS AND CLASSICAL VRFT $C(q, \theta)$ CONTROLLER.

Method	$C(q, \theta)$		Volterra-Kautz		Volterra- Laguerre	
$\mathcal{N}_{iid}(0, \sigma^2)$	0.000	0.1000	0.000	0.1000	0.000	0.1000
ITAE*	18.94	59.71	3.820	2.479	6.655	8.243

After all simulations, it can be said that the closed-loop performance of the system when using both Volterra-Laguerre and Volterra-Kautz (N)OBF control structures in VRFT technique is successfully improved not only in noisy free system but also when the input-output data collected from the plant is disturbed by an signal v . That leads to several conclusions about the method presented in this study. Most of them are discussed in Section 4.5.

4.4.2 Continuous Stirred Tank Reactor (CSTR) case study

This example applies Volterra-OBF controller in a Continuous Stirred Rank Reactor (CSTR), one of the most important devices in chemical field (SEBORG et al, 2004) and a challenging task to use the VRFT and Volterra-OBF proposed on this thesis. The CSTR, well addressed by (DOYLE et al, 2001), is a plant frequent characterized and studies by its nonlinearities, input/output constrains, high order models and uncertainties. In this context, a solution to describe the CSTR plant using Volterra series needs a large

number of coefficients due to its highly nonlinear behaviour and Volterra-OBF approach can be an handful solution to minimize the computational cost of the identification step.

Thus, consider a nonlinear CSTR process as given by (DOYLE et al, 2001) and Figure (4-12). It represents an isothermal free-radical polymerization of methyl methacrylate using azo-bis-isobutyronitrile as initiator and toluene as solvent.

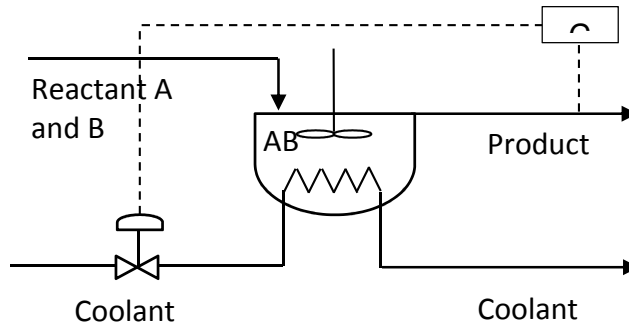

FIGURE 4-12. CONTINUOUS STIRRED TANK REACTOR

From the process described on Equation (4-15) and Figure (4-12), the average number of molecular weight, $y(t)$, is controlled by manipulating the inlet initiator flow rate given by $u(t)$. From the same Equation, x_1 to x_4 are state space variables not directly manipulated and with nominal operations given by: $x_{1,2} = 5.50677$, $x_{2,0} = 0.132906$, $x_{3,0} = 0.0019752$, $x_{4,0} = 49.3818$, $u_0 = 0,016783$ and $y_0 = 25000.5$. Model time constants are given in hours and the input/output signal units are m^3/h and $kg/kmol$, respectively.

After all, the model which relates the input/output signals is given by:

$$\begin{cases} \dot{x}_1(t) = 1(6 - x_1(t)) - 2.456x_1(t)\sqrt{x_2(t)} \\ \dot{x}_2(t) = 2u(t) - 1.1222x_2(t) \\ \dot{x}_3(t) = 2.22412x_1(t)\sqrt{x_2(t)} + 2.112191x_2(t) - 1x_3(t) \\ \dot{x}_4(t) = 245.97x_1(t)\sqrt{x_2(t)} - 1x_4(t) \\ y(t) = x_4(t)/x_3(t) \end{cases} \quad (4-15)$$

Similarly to the previous Section, initially both classical and Volterra-OBF controllers are compared regarding identification performance. The goal is to obtain an u' output as close as possible to e signal, which is given by Equation (4-2) and means the error between the controlled system and the required performance (reference transfer function);

Secondly, the closed-loop performance is evaluated and a further comparison is made between Volterra-Laguerre and Volterra-Kautz functions.

Thus, consider that one set of data is collected from the plants as part of the experimental step for use on the VRFT procedure. The input is a uniformly spaced set of random amplitude steps and both I/O data are normalized values for the input and output nominal operation value with time step of 0.03h.

Finally, it is necessary to define the desired behavior of the system T and, in the case of the classical design of the VRFT, a class of controller C^* . In this case the class chosen does not contain the structure of the ideal controller.

Reference Model:

$$T(q) = \frac{0.001q}{q - 0.999} \quad (4-16)$$

Control Structure:

$$C(q, \theta) = \frac{\theta_1 q^2 + \theta_2 q + \theta_3}{q(q - 1)} \quad (4-17)$$

For controlling purposes in real systems, it is desirable to know the feasibility of the input and output signals being identified and used as reference..

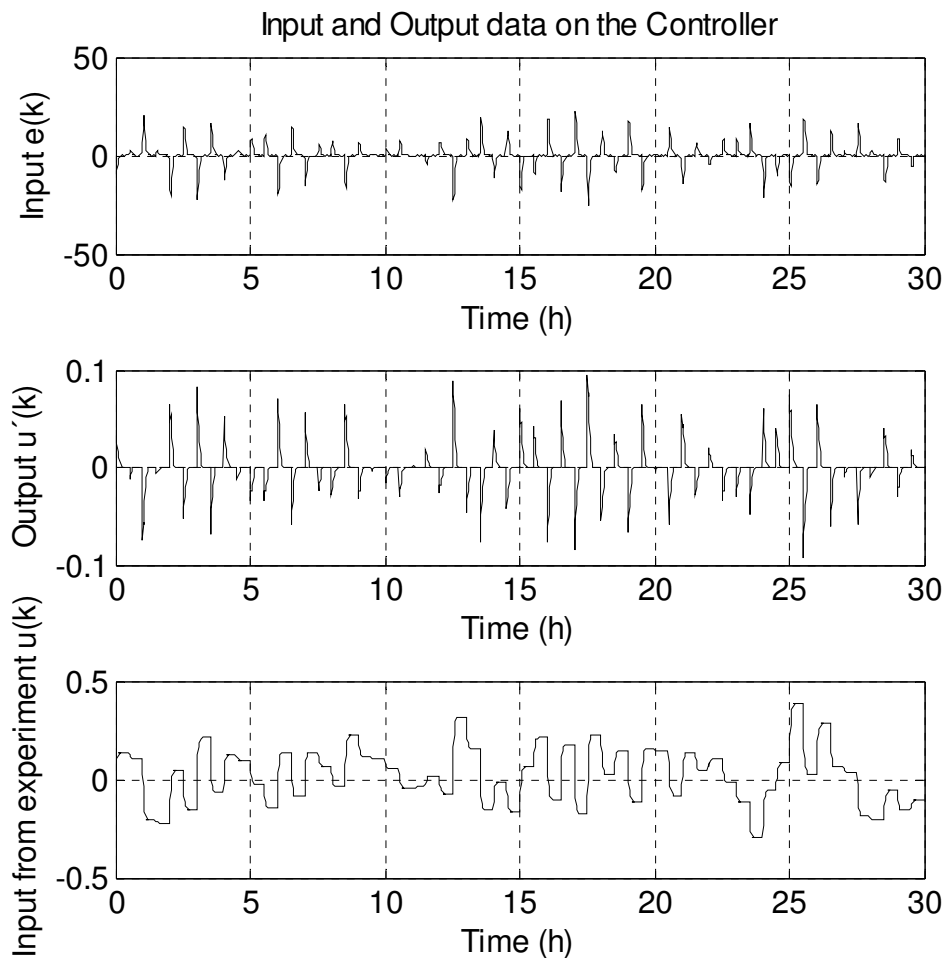

FIGURE 4-13. FIRST CHART: INPUT OF THE CONTROLLER - e ; SECOND CHART: OUTPUT u' ; THIRD CHART: REAL INPUT FROM EXPERIMENTS u .

Figure (4-13) shows the input and output signals u , u' and e for the closed-loop system in study, every signal proposed in the system is capable of being implemented in a real situation. It is worth remembering that the reference signal e does not exist in reality and is only used for mathematical purposes.

Given the controller class chosen by the Equation (4-18), the computed parameter for the controller were:

$$\theta = [0.4972 \ 0.2036 \ 9.740 \times 10^{-2}]^T$$

$$C(q) = \frac{0.4972q^2 + 0.2036q + 9.740 \times 10^{-2}}{q(q-1)} \quad (4-18)$$

From Equation (4-19), Figure (4-14) shows the identification result for classical VRFT approach.

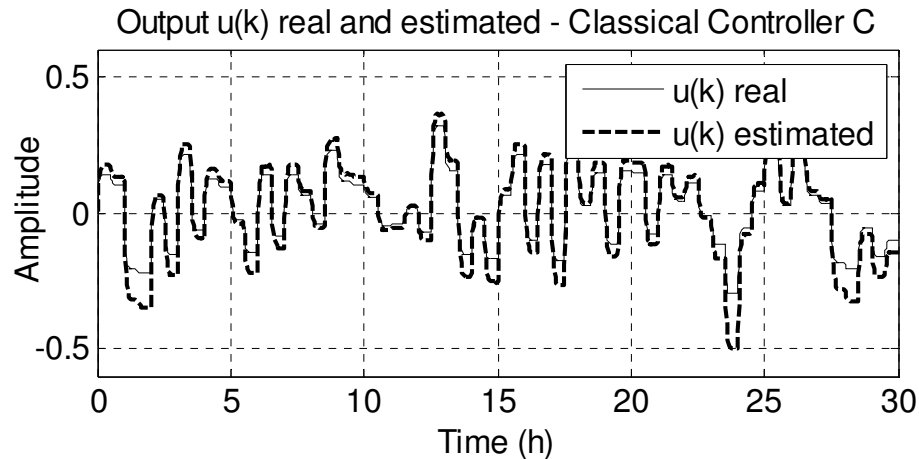

FIGURE 4-14. IDENTIFICATION STEP FROM I/O DATA WHEN THE CONTROLLER CLASS DOES NOT BELONG TO THE CLASS OF THE IDEAL CONTROLLER (CLASSICAL IDENTIFICATION).

In addition, Figure (4-15) shows the results obtained using Volterra-Laguerre model, followed by Figure (4-16) with Volterra-Kautz results. The main idea behind those charts is to compare identification performance from both classical and Volterra-OBF approaches when the classical class of controller does not contain the ideal one. The basic Volterra-Laguerre and Volterra-Kautz poles are chosen from the best identification MSE result from a range of valid values. For both Volterra-Laguerre and Volterra-Kautz OBF controller structures, the number of orthonormal function used are given by $\{n_1, n_2 = 6, 4\}$ from Equation (4-7).

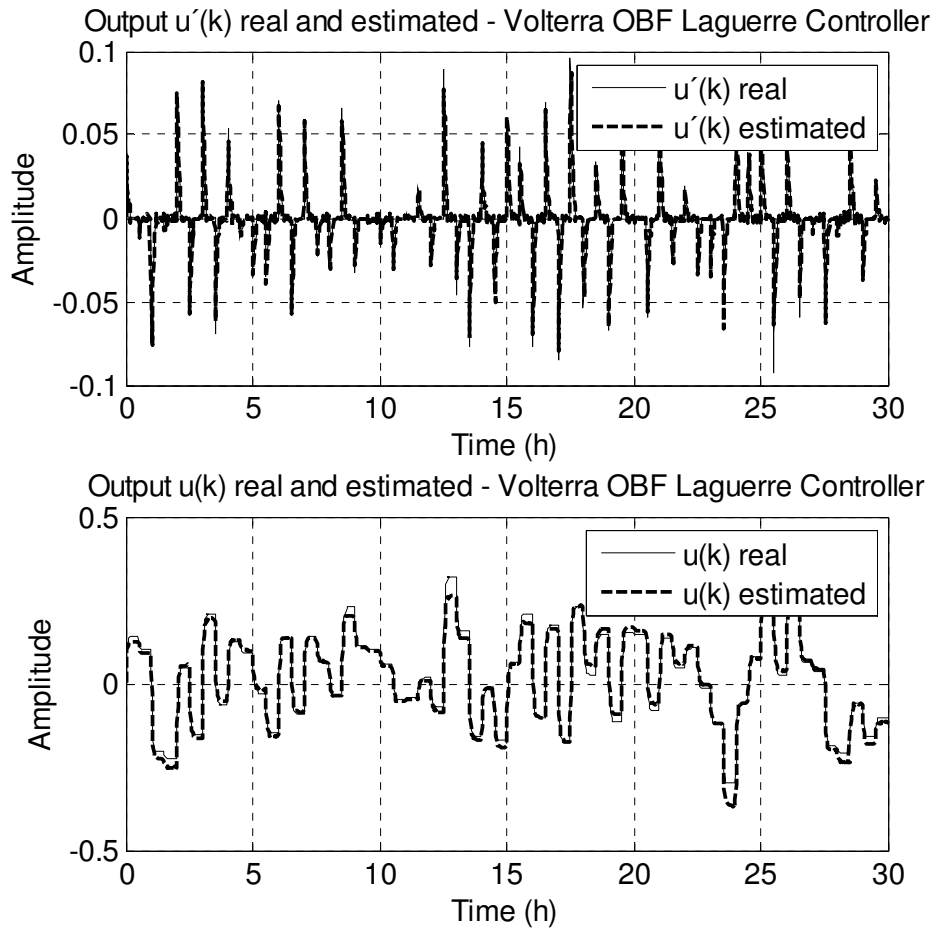

FIGURE 4-15. IDENTIFICATION STEP FROM I/O DATA GIVEN u REAL AND u' ESTIMATED.

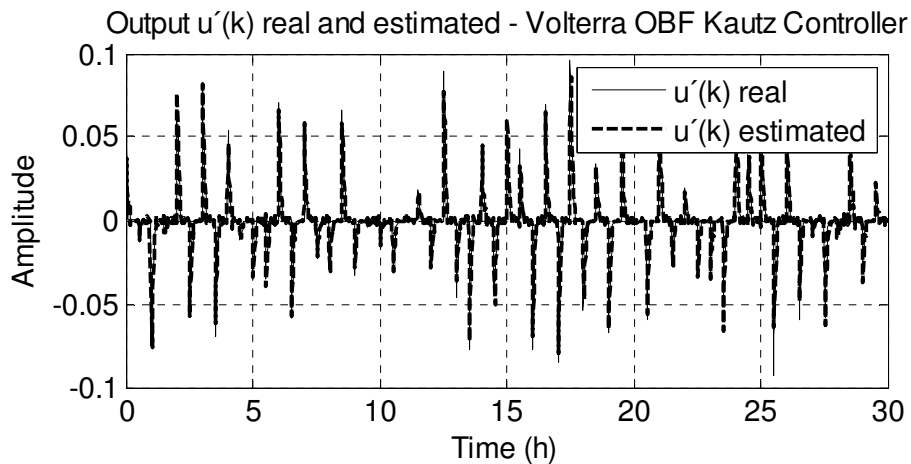

FIGURE 4-16a. THE IDENTIFICATION STEP FROM I/O DATA WHEN THE CONTROLLER CLASS DOES NOT BELONG TO THE CLASS OF THE IDEAL CONTROLLER (CLASSICAL IDENTIFICATION) AND RESULT WHEN A VOLTERRA-KAUTZ CONTROLLER CLASS IS CHOSEN (OBF IDENTIFICATION).

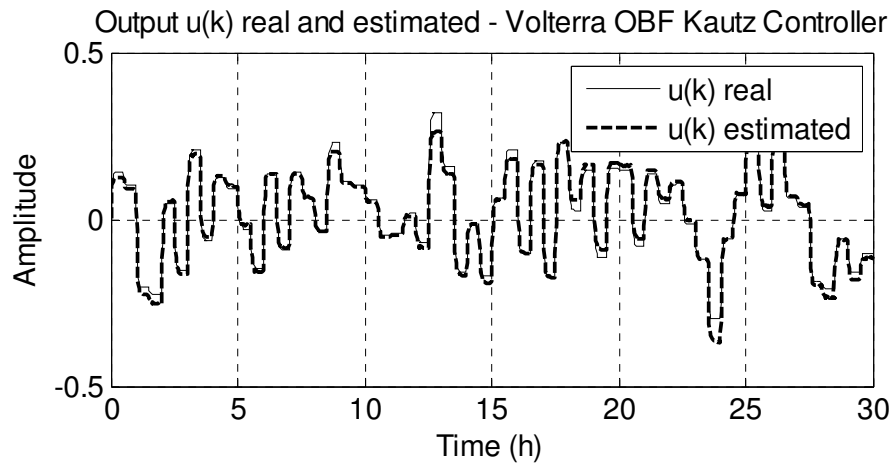

FIGURE 4-16b. THE IDENTIFICATION STEP FROM I/O DATA WHEN THE CONTROLLER CLASS DOES NOT BELONG TO THE CLASS OF THE IDEAL CONTROLLER (CLASSICAL IDENTIFICATION) AND RESULT WHEN A VOLTERRA-KAUTZ CONTROLLER CLASS IS CHOSEN (OBF IDENTIFICATION).

For better visualization and statistical comparison between the different models used, the Figure (4-17) shows the distribution of estimation error of the u' signal for both Volterra-OBF Laguerre and Volterra-OBF Kautz results earlier presented. It is possible to conclude that the distribution of the combined standard uncertainty tends towards a normal (or gaussian) with standard deviation of 0.02012 for Volterra-Kautz and 0.02521 for Volterra-Laguerre identification.

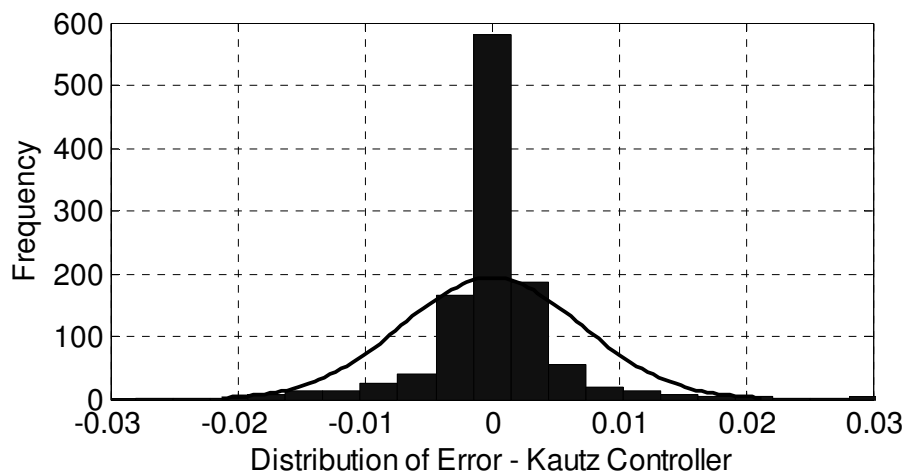

FIGURE 4-17a. ESTIMATION OF u AND u' USING OBF KAUTZ CLASS OF CONTROLLER.

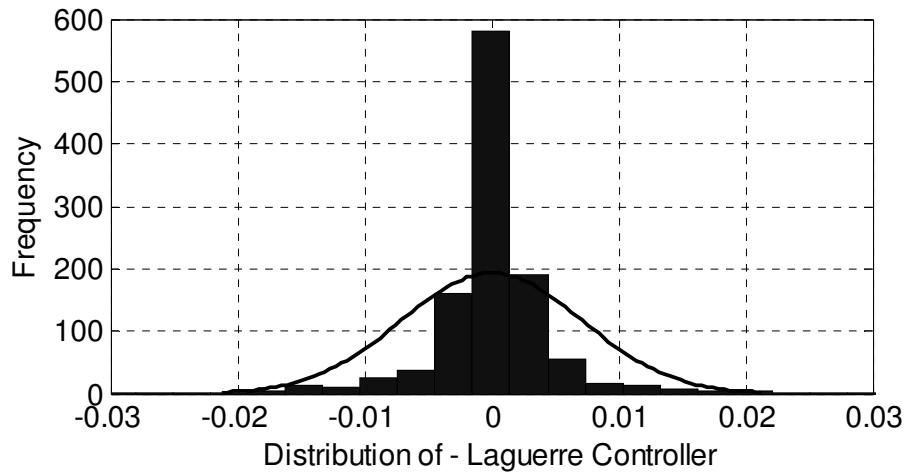

FIGURE 4-17b. ESTIMATION OF u AND u' USING OBF KAUTZ CLASS OF CONTROLLER.

The following Tables summarizes the responses obtained from Volterra-Laguerre and Volterra-Kautz functions as well their behavior with different noise levels. Every ITAE result and MSE value is calculated based on the estimated and real u' and u data, respectively.

TABLE 4-4. RESULTS OF VOLTERRA-LAGUERRE METHOD FOR EACH VALUE OF NOISE DISTURBANCE.

Method	Volterra-Laguerre	Volterra-Kautz
Best pole	0.001	$0.1010 \pm 0.0010i$
MSE	3.8720×10^{-4}	3.9054×10^{-4}

TABLE 4-5. RESULTS USING CLASSICAL VRFT TECHNIQUE AND QUANTITY OF NOISE DISTURBANCE v .

Method	$C(q, \theta)$
MSE	2.604×10^{-3}

Coefficients $[\theta_1, \theta_2, \theta_3]^T$	$\begin{bmatrix} -7.112 \times 10^{-3} \\ 5.385 \times 10^{-3} \\ -3.203 \times 10^{-3} \end{bmatrix}$
---	--

The following charts shows the closed-loop performance of the system for both Volterra-Laguerre and Volterra-Kautz (Figure 4-18) comparing to the desired performance given by the transfer function T and the result obtained with the classical VRFT procedure.

From Figure (4-18), it can be observed the misbehaviour of the classical VRFT approach facing OBF approach for controller identification. Although the exact desired performance haven't been obtained, the results with OBF controller are closer than the classical VRFT. Figure (4-19) shows a time weighted absolute error between desired and real Closed-Loop performance when applying the Volterra-OBF controller using Laguerre

and then Kautz functions and, as a final point, Table (4-6) summarizes the responses between Laguerre and Kautz functions as well their behavior with different noise levels.

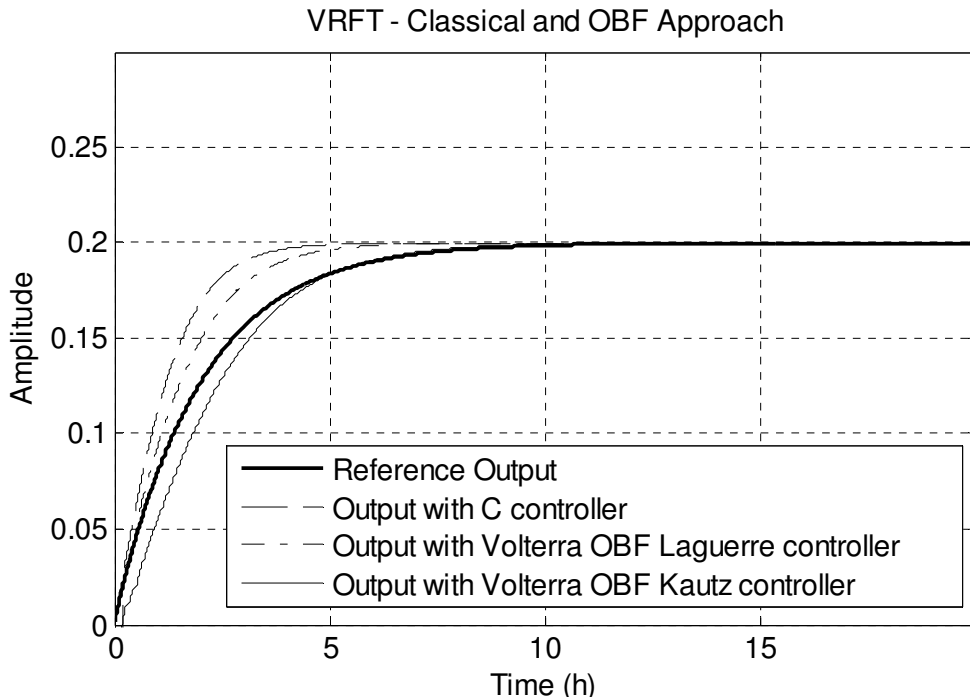

FIGURE 4-18. RESULT OF CLOSED-LOOP STEP FROM IO DATA WHEN THE CONTROLLER CLASS DOES NOT BELONG TO THE CLASS OF THE IDEAL CONTROLLER (CLASSICAL IDENTIFICATION) AND RESULT WHEN A VOLTERRA-OBF CONTROLLERS (OBF IDENTIFICATION).

Every ITAE result and MSE value on both Figure (4-19) and Table (4-6) is calculated based on the reference transfer function T .

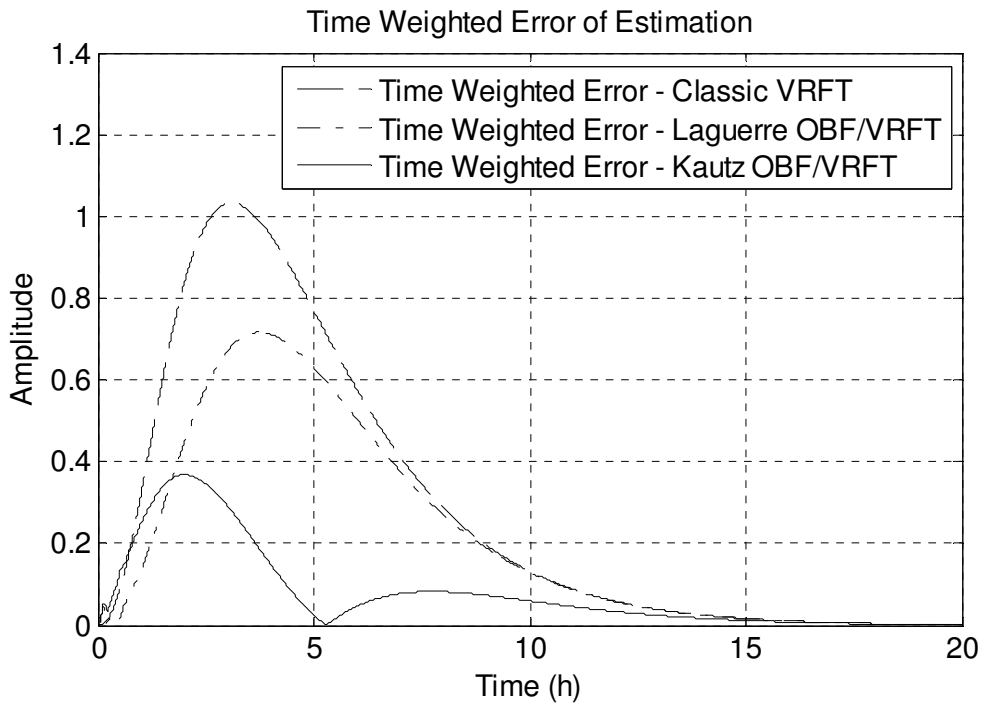

FIGURE 4-19. A TIME WEIGHTED ABSOLUTE ERROR BETWEEN REFERENCE AND REAL CLOSED-LOOP OUTPUT y WHEN USING LAGUERRE-VOLTERRA OBF CONTROLLER WHEN THE SYSTEM IS NOISE FREE.

TABLE 4-6. SUMMARY OF RESULTS OF VOLTERRA-KAUTZ, VOLTERRA-LAGUERRE FUNCTIONS AND CLASSICAL VRFT $C(q, \theta)$ CONTROLLER.

Method	Volterra-Laguerre	Volterra- Kautz	$C(q, \theta)$
ITAE*	14.40×10^2	5.310×10^2	19.22×10^2

After all simulations, it can be said that the closed-loop performance of the system when using both Volterra-Laguerre and Volterra-Kautz OBF control structures in VRFT technique, is successfully improved. That leads to several conclusions about the method presented in this study. Most of them are discussed as follows.

4.5 Conclusion

The objective proposed in this Chapter is to present a technique that generalizes the structure of the given controller via virtual reference method contributing to the development and applicability of the VRFT technique and identification method based on data for nonlinear systems.

The mean square error of the controller identification step and consequently the ITAE criteria during closed-loop evaluation becomes smaller when Volterra-Kautz functions are applied comparing to Volterra-Laguerre system. This result becomes more significant the more noise signal is inserted in the system through the $v(k)$ signal (find Table 4-1 to 4-7).

After all, it is possible to observe that the data-driven controller obtained by the virtual reference method (VRFT) with structure based on Volterra-OBF can adapt to the ideal controller with better efficiency than the classical approach, even when it comes about a CSTR reactor which is a known by its highly nonlinear behaviour. Thus, both Volterra-Laguerre and Volterra-Kautz models resulted in better results than the classical method to find the controller.

Nevertheless, as also expected, the results with Volterra-Kautz functions were more accurate regarding ITAE results due better identification of the dynamics between e and u' . Further details and results can be found in the Chapter 2.

In this context, as noted in Section 4.4 and Chapter 2, the controller parameterization in VRFT technique through the method of Volterra-Orthonormal basis functions proved to be efficient and served its purpose. The applicability of such method is great since the Volterra-OBF models are limited by a few general conditions that serves

for the majority of real cases. After all, the VRFT technique is improved and consequently its applicability and accuracy when applied in noisy and nonlinear systems.

5 CONCLUSIONS AND FUTURE WORK

An alternative approach to the problem of sub-optimal controller tuning due weak choice of a class of structures in the VRFT technique is presented in this thesis. In this Chapter, first a summary of the technique presented is prepared. Finally, it discusses the conclusions, limitations and future research avenues when using Orthonormal Basis Functions to solve the problem.

5.1 Conclusions

This work outlined a new method to enhance accuracy of the Virtual Reference Feedback Tuning technique on identification step and provide better controller parameterization given a reference signal. In the beginning of Chapter 2 a briefly explanation about the OBF model is presented, the main objective was to highlight the main characteristics of such solution and better explain why it is a great answer for generalize the VRFT class of controllers and provide far better results in identification and closed-loop system.

In the following Chapter, the discussion of the use of OBF on the VRFT technique is focussed on linear systems. A first simulation case based on the impulsive response of the plant delivered superior results than the classical approach by using both Kautz and Laguerre OBF in a noise-free and linear system. Furthermore, by using the direct approach, the application of the OBF is widespread for input signals other an impulse and under noisy systems. The results obtained presented good accuracy and the closed-loop response was much closer to the reference signal comparing to the fixed structure technique.

With the purpose of strengthen understanding of the key concepts being studied, in Chapter 4 a nonlinear system is tested with an OBF controller constructed using both Volterra-Laguerre and Volterra-Kautz functions. At this time, a normal distributed signal with zero average was used to obtain the set of data from the plant in a more feasible and generalized way for practical applications. The main objective was to direct identify the controller parameters given the tracking error and the input signal from the initial data. At this time, each coefficient of the orthonormal functions is determined using the least square algorithm and the best pole is selected from a valid range by its MSE value during

identification step. The orthonormal filters and its coefficients are part of the Volterra kernel with a finite number of Equations chosen to identify the controller dynamics. This new technique is also applied in two cases. The first one intended to compare different number of filters in the Volterra kernel and the response of the Volterra-OBF controller under noise input. The second case is based on a chemical reactor plant whose nonlinearity is highly studied and known. In both cases, the developed Volterra-OBF controller succeeded on approximating with great accuracy the reference and real responses even with a small quantity of functions (four in the first case, 4/6 in the second). Comparing the result to the classical VRFT approach, the ITAE value are more expressive and assures the efficiency of the method proposed on this thesis.

After all, the results obtained show the efficiency on the use of the Orthonormal Basis Functions on linear systems and Volterra-Orthonormal Basis Functions on nonlinear systems to generalize de controller structure in the Virtual Reference Tuning technique where the mathematical foundations of both OBF and Volterra-OBF models have been discussed in the context of system identification. In sum, all these approaches through the simulation cases presented provided evidence to deeply evaluate and affirm the capability and applicability of the proposed tool for a wide class of dynamic systems whose controller is be tuned using the VRFT procedure.

5.2 Limitations

The method presented in this thesis has a few design limitations generally related to the use of Orthonormal Basis Functions to identify the controller.

Although the Orthonormal Basis Filter (OBF) models have several characteristics that turn it into a very attractive tool for identifying controllers such as the consistence in parameters - easily calculated using least squares algorithm - there are several issues that are not yet solved. One of these issues is that OBF is not able to provide a noise model which, in real cases where the VRFT technique is applied and the initial data has interference of noise data, the identification of the controller is accurate but the overall performance of the closed-loop system could be better.

5.3 Future Work

In this Section, it is described a few avenues that could be explored in the next phases of this research.

Some possibilities of future focus are to make the system automatically select the number of Laguerre and Kautz functions by adding the ability to automatically search for the best residual energy or identification MSE during identification step.

Additional improvements will be to compare and evaluate the use of generalized functions such as Takenaka Malmquist even considering the complex determination of poles in this model as well widespread the fixed class of controllers in classical approach for linear systems.

Furthermore, regarding plants and systems under noise, there is an opportunity of reducing the sensitiveness of the OBF-VRFT method proposed in this thesis to provide a better result on closed-loop system under noisy system. As one possible solution to address this problem (TUFA et al., 2009) proposed a two-stage method capable of providing a consistent OBF deterministic model and an explicit noise model for open-loop stable systems, which is the majority of cases when applying the VRFT technique to identify the controller.

REFERENCES

- AGUIRRE, L. **Introdução à identificação de sistemas—técnicas lineares e não-lineares aplicadas a sistemas reais**. 3.ed. Belo Horizonte: UFMG, 2007.
- ASTROM, K. J.; HAGGLUND, T. **PID Controllers: Theory, design and tuning**. 2.ed. North Carolina, USA: Instrument Society of America, 1995.
- BAZANELLA, A. S.; CAMPESTRINI, L. ECKHARD, D. Data-Driven Controller Design the H2 Approach. 1st.ed. Netherlands: **Springer**, 2012.
- BILLINGS, S. A. Identification of nonlinear systems – a survey. **IEEE Proc.** Part D 127(6), 272–285, 1980.
- BRAGA, A. S. **Modelos de Volterra: identificação não paramétrica e robusta utilizando funções ortonormais de Kautz e generalizadas**. Originally Presented as the author’s Master’s thesis. Universidade Estadual de Campinas, Campinas, 2011.
- BOYD, S.; CHUA L. O. Volterra Series for Nonlinear Circuits, **International Symposium on Circuits and Systems Proc.**, V. 1, P. 369, 1985.
- CAMPELLO, R.J.G.B. **Arquiteturas e Metodologias para Modelagem e Controle de Sistemas Complexos utilizando Ferramentas Clássicas e Modernas**. Originally Presented as the author’s Doctoral thesis, Universidade Estadual de Campinas, Campinas, 2002.
- CAMPELLO, R.J.G.B.; OLIVEIRA, G.H.C.; AMARAL, W.C. Identificação E Controle De Processos Via Desenvimentos Em Séries Ortonormais. Parte A: Identificação. **Sociedade Brasileira de Automatica**, Natal, V. 18, P. 323–336, 2007.
- CAMPESTRINI, L. **Contribuições para métodos de controle baseados em dados obtidos em apenas um experimento**. Originally Presented as the author’s Doctoral thesis, Universidade Federal Do Rio Grande Do Sul, Porto Alegre, 2010.
- CAMPESTRINI, L; ECKHARD, D; GEVERS, M.; BAZANELLA, A.S. Virtual Reference Feedback Tuning for non-minimum phase plants. **Automatica**, Londres, V. 47, N. 8, P. 1778–1784, 2011.
- CAMPI, M. C.; SAVARESI, S. M. Direct Nonlinear Control Design: The Virtual Reference Feedback Tuning (VRFT) approach. **IEEE transactions on automatic control**. V. 51, N. 1, P. 14–27, 2006.
- CAMPI, M. C.; LECCHINI, A.; SAVARESI, S. M. An application of the virtual reference feedback tuning method to a benchmark problem. **European Journal of Control**. N. 9, P. 66–76, 2003.
- CAMPI, M. C.; LECCHINI, A.; SAVARESI, S. M. Virtual reference feedback tuning: a direct method for the design of feedback controllers. **Automatica**, Londres, V. 38, N. 8, P. 1337–1346, 2002.

CUNHA, M. F. F.; BAZANELLA, A.S. Virtual Reference Feedback Tuning with Dead Zone Compensation. **Anais do XIX CBA**. Campina Grande, P.1093 – 1099, 2012.

DA ROSA, A. ; CAMPELLO, R. J. G. B. Exact search directions for optimization of linear and nonlinear models based on generalized orthonormal functions. **IEEE Transactions on Automatic Control**. V.54, PP. 2757-2772, 2009.

DA ROSA, A.; AMARAL, W. C. e CAMPELLO, R. J. G. B. Desenvolvimento de modelos de Volterra usando funções de Kautz e sua aplicação na modelagem de um sistema de levitação magnética. **Proc. XVI Congresso Brasileiro de Automática**. Salvador, 2006.

DA ROSA, A. **Identificação de Sistemas Não-Lineares Usando Modelos de Volterra Baseados em Funções Ortonormais de Kautz e Generalizadas**. Originally Presented as the author's Doctoral thesis, Universidade Estadual de Campinas, Campinas, 2009.

DA ROSA, A.; CAMPELLO, R. J. G. B.; FERREIRA, P. A. V.; OLIVEIRA, G. H. C.; AMARAL, W. C. Robust expansion of uncertain Volterra kernels into orthonormal series. **In Proc. American Control Conference**. Baltimore, EUA, 2010.

DA ROSA, A. **Despendimento de Modelos Discretos de Volterra Usando Funções de Kautz**. Originally Presented as author's Master's thesis, Universidade Estadual de Campinas, Campinas, 2005.

DOYLE, F.J; OGUNNAIKE, B.A.; PEARSON, R.K. **Identification and control Using Volterra Models**. Communications and Control Engineering. Springer, 2001.

EYKHOFF, P. (1974). **System Identification: Parameter and State Estimation**. JohnWiley; Sons. New York.

FAVIER, G.; KIBANGOU, A.Y.; BOUJILLOC, T. Nonlinear system modeling and identification using Volterra-PARAFAC models. **Int. J. Adapt. Control Signal Process**.P.26:30–53, 2012.

FORMENTIN, S.; KARIMI, A.; SAVARESI, S. M. Optimal input design for direct data-driven tuning of model-reference controllers. **Automatica**. P.1874 – 1882, 2013.

FU, Y; DUMONT, G.A. An optimum time scale for discrete Laguerre network. **IEEE Transactions on Automatic Control**, 38(6):934-938, 1993.

GUARDABASSI, G. O.; SAVARESI, S. M.; Approximate Feedback Linearization of Discrete Time Nonlinear Systems using Virtual Input Direct Design. **Systems; Control Letters**, 32, 63–67, 1997.

GUARDABASSI, G. O.; SAVARESI, S. M. Approximate linearization via feedback: An overview. **Automatica**, V.37 (1), P.1–15, 2001.

GUARDABASSI, G. O.; SAVARESI, S. M. Virtual reference direct design method: an online approach to data-based control system design. **IEEE Transactions on Automatic Control**, 45(5), 954–959, 2000.

HEUBERGER, P.; VAN DEN HOF, P.M.J.; WAHLBERG, B. **Modeling and identification with rational orthogonal basis functions**. Springer-Verlag, Londres, 2005.

HEUBERGER, P; VAN DEN HOF, P.M.J.; BOSGRA, O. A generalized orthonormal basis for linear dynamical systems, **IEEE Trans. Automat. Control** AC-40 451-465, 1995.

HJALMARSSON, H.; GERVERS, M.; GUNNARSSON, S.; Convergent iterative restricted complexity control design scheme. **Proc. 33rd IEEE Conf. on Decision and Control**, Orlando, Florida, P. 1735-1740, 1994.

HOOG DE, T. **Rational Orthonormal Bases and Related Transforms in Linear System Modeling**. Originally Presented as the author's Doctoral thesis, Dutch Institute of Systems and Control DISC, Minneapolis, Verenigde Staten, 2001.

HUUSOM, J.K; HJALMARSSON, H.; POULSEN, N.K.; JORGENSEN, S.B.; A design algorithm using external perturbation to improve iterative feedback tuning convergence, **Automatica**, V. 47, no. 12, P. 2665–2670, 2011.

KANSHA, Y.; HACHIMOTO, Y.; CHIU, M. New results on VRFT design of PID controller. **Chemical Engineering Research and Design**, N. 86, P. 925–931, 2008.

KARIMI, A.; MISKOVIC, L.; BONVIN, D. Iterative correlation-based controller tuning. **International Journal of Adaptive Control and Signal Processing**, V. 18, N. 8, P. 645–664, 2004.

LECCHINI, A.; CAMPI, M; C; SAVARESI, S.M. Virtual reference feedback tuning for two degree of freedom Controllers. **International Journal of Adaptive Control and Signal Processing**, 16 355-371, 2002.

LJUNG, L. **System identification: Theory for the user**. Englewood Cliffs, NJ: Prentice-Hall, 1999.

MACHADO, J.B. **Modelagem de Sistemas Não-lineares por Base de Funções Ortonormais Generalizadas com Funções Internas**. Originally Presented as the author's Doctoral thesis, Universidade Estadual de Campinas, Campinas, 2011.

MAESTRELLI, R. **Funções Ortonormais em Tempo Contínuo com Seleção Otimizada das Dinâmicas do Modelo na Identificação de Sistemas no Domínio da Frequência**. Originally Presented as the author's Master's thesis, Universidade Federal do Paraná, Curitiba, 2010.

NEUHAUS, T. **Projeto de controladores não lineares utilizando referência virtual**. Originally Presented as the author's Master's thesis, Universidade Federal do Rio Grande do Sul, Porto Alegre, 2012.

NELLES, O. **Nonlinear System Identification**. From Classical Approaches to Neural Networks and Fuzzy Models. Springer-Verlag Berlin Heidelberg, Germany, 2001.

NIJMEIJER, H.; SAVARESI, S. M. On approximate model-reference control of SISO discrete-time nonlinear systems. **Automatica**, 34(10), 1261–1266, 1998.

NINNESS, B.; GUSTAFSSON, F. A unifying construction of orthonormal bases for system identification. **IEEE Transactions on Automatic Control**, 42(4), 515–521, 1997.

NINNESS, B.; HJALMARSSON, H.; GUSTAFSSON, F. **The fundamental role of general orthonormal bases in system identification**. IEEE Trans. Auto. Cont 44(8), P. 1999.

NINNESS, B.; HJALMARSSON, H.; GUSTAFSSON, F. **Generalized Fourier and Toeplitz results for rational orthonormal bases**. SIAM J. Cont & Optim 37(2), 429–460, 1999.

OLIVEIRA, G. H. C. **Controle preditivo para processos com incertezas estruturadas baseado em series de funções ortonormais**. Originally Presented as the author's Doctoral thesis, Universidade Estadual de Campinas, Campinas, 1997.

OLIVEIRA, G. H. C.; CAMPELLO, R.J.G.B.; AMARAL, W.C. Identificação e controle de processos via desenvolvimentos em séries ortonormais. Parte B: Controle Preditivo. **Revista Controle e Automação**, V. 18, N. 3, P. 322-336, 2007.

OLIVEIRA, G. H. C.; AMARAL, W. C.; LATAWIEC, K. CRHPC Using Volterra models and orthonormal basis functions: An application to CSTR plants, **Proc. of the IEEE Conference on Control Applications**, V. 1, Istanbul/Turkey, P. 718–723, 2003.

OLIVEIRA, G. H. C.; ROSA, A.; CAMPELLO, R.J.G.B.; MACHADO, J.B.; AMARAL, W.C. An introduction to models based on Laguerre, Kautz and other related orthonormal functions – Part I: linear and uncertain models. **International Journal of Modeling, Identification and Control**, V. 14, N. 1/2, P. 121-132, 2011.

OLIVEIRA, G. H. C.; ROSA, A.; CAMPELLO, R.J.G.B.; MACHADO, J.B.; AMARAL, W.C. An introduction to models based on Laguerre, Kautz and other related orthonormal functions: Part II nonlinear models. **International Journal of Modeling, Identification and Control**, V. 16, P. 1-14, 2012.

REGINATO, B.C.; OLIVEIRA, G. H. C. On Selecting the MIMO Generalized Orthonormal Basis Functions Poles by Using Particle Swarm Optimization. **Proc. of the European Control Conference (ECC)**, Greece, 2007.

REGINATO, B. C.; OLIVEIRA, G. H. C. Algoritmo Híbrido para Seleção de Pólos em Modelos Formados Por Bases de funções Ortonormais Generalizadas. **Congresso Brasileiro de Automática**, Juiz de Fora, 2008.

REGINATO, B.C. **Ambiente Computacional para Identificação no Domínio do Tempo e da Frequência usando Bases de Funções Ortonormais**. Originally

Presented as the author's Master's thesis, Pontifícia Universidade Católica do Paraná, Curitiba, 2008.

RODRIGUES, G.; CAMPESTRINI, L. ; BAZANELLA, A.S. Automating the choice of the reference model for data-based control methods applied to PID controllers, **XX Congresso Brasileiro de Automática**, Belo Horizonte, 2014.

SAVARESI, S. M.; GUARDABASSI, G. M. Approximate I=O feedback linearization of discrete-time nonlinear systems via virtual input direct design. **Automatica**, 34(6), 715–722, 1998.

SCHETZEN, M. **The Volterra and Wiener Theories of Nonlinear Systems**. John Wiley & Sons, 1980.

SILVA, T. O. On the determination of the optimal pole position of Laguerre filters. **IEEE Transactions on Signal Processing**, V. 43, N. 9, P. 2079–2087, 1995.

SILVA, T. O. Optimal pole conditions for Laguerre and two-parameter Kautz models: A survey of known results, **Proc. of the IFAC Symposium on System Identification (SYSID)**, USA, 2000.

SODERSTROM, T.; STOICA, P. **System Identification**. Hemel Hempstead, Hertfordshire: Prentice-Hall International, 1989.

SONI, A.S. **Control-Relevant System Identification using Nonlinear Volterra and Volterra-Laguerre Models**. Originally Presented as the author's Doctoral thesis, University of Pittsburgh, 2006.

SJÖBERG, J; ZHANG, Q; LJUNG, L. Nonlinear black-box modeling in system identification: a unified overview. **Automatica**, 31 (12), 1691-1724, 1995.

TAKENAKA, S. On the orthogonal functions and a new formula of interpolation. **Japanese J. Math.**; V. II, P. 129–145, 1925.

TUFA, L.D.; RAMASAMY, M.; SHUHAIMI, M. Closed Loop System identification using OBF-ARMAX Model. **Journal of Applied Sciences**, 3175-3172, 2010.

TUFA, L.D.; RAMASAMY, M.; SHUHAIMI, M. Closed Loop Identification Using Orthonormal Basis Filter (OBF) and Noise Models. **Proc. of AIChE Annual Meeting**, Nashville, USA, 2009.

TUFA, L.D.; RAMASAMY, M. System Identification Using Orthonormal Basis Filter. **Frontiers in Advanced Control Systems** 253-276, 2012.

WAHLBERG, B. System identification using Kautz models, **IEEE Trans. on Automatic Control**, 39(6): 1276– 1282, 1994.

WAHLBERG, B. System identification using Laguerre models. **IEEE Transactions on Automatic Control**, 36(5), 551–562, 1991.

WANG, L.; CLUETT, W.R. **From Plant Data to Process Control. Ideas for process identification and PID design.** New York, NY. Taylor and Francis, 2000.

WANG, L. **Model Predictive Control System Design and Implementation Using MATLAB.** London. Springer-Verlag, 2009.

WIENER, N. **Nonlinear Problems in Random Theory.** The MIT Press, New York, 1958.

VOLTERRA, V. **Theory of Functionals and of Integral and Integro-Differential Equations.** Dover, New York, 1959.

YANG, X.; YAN Li; YASUKI K.B.; Min S.C. Enhanced VRFT design of adaptive PID controller. **Chemical Engineering Science**, V. 76, P. 66–72, 2012.

ZHANG, H. T.; Chen, Z. H.; Wang Y. J.; Qin, T. ; Li, M. Adaptive predictive control algorithm based on Laguerre Functional Model. **Int. J. Adaptive Control and Signal Processing**, 20(2), P. 53-76, 2006.

ZHU A, BRAZIL T.J. RF Power amplifier behavioral modeling using Volterra expansion with Laguerre functions. **Proc. of the IEEE International Microwave Theory and Techniques Symposium**, Long Beach, V. WE4D-1, 2005.

ZIEGLER, J. G.; NICHOLS, N. B. Optimum settings for automatic controllers. **Transactions of the ASME**, 64, 759–768, 1942.